

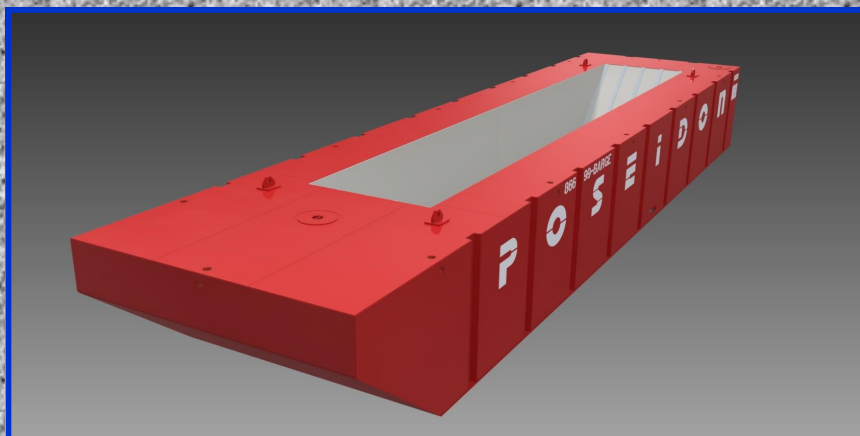

Poseidon Barge Hopper

(No Castings)

The Poseidon Hopper Barge is a stand alone unit designed for heavy duty use on dredging & rip-rap projects. Ideal for inland river, lakes and pond mechanical dredging projects. The Poseidon Hopper Barge is trucked to the site. Call for lead time & pricing.

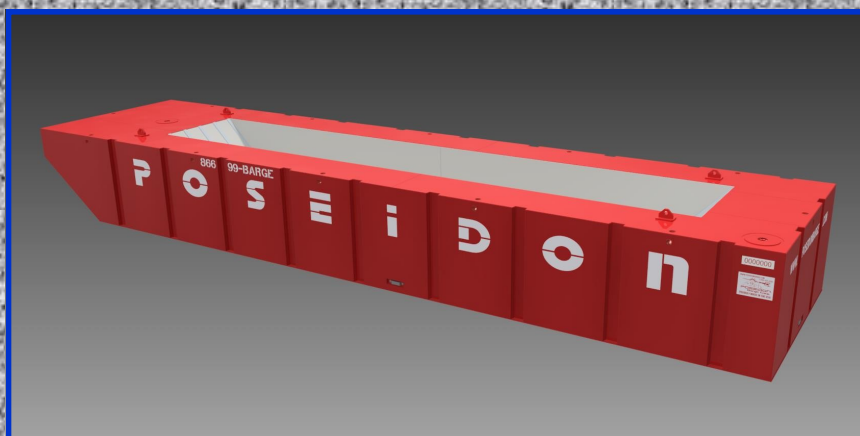
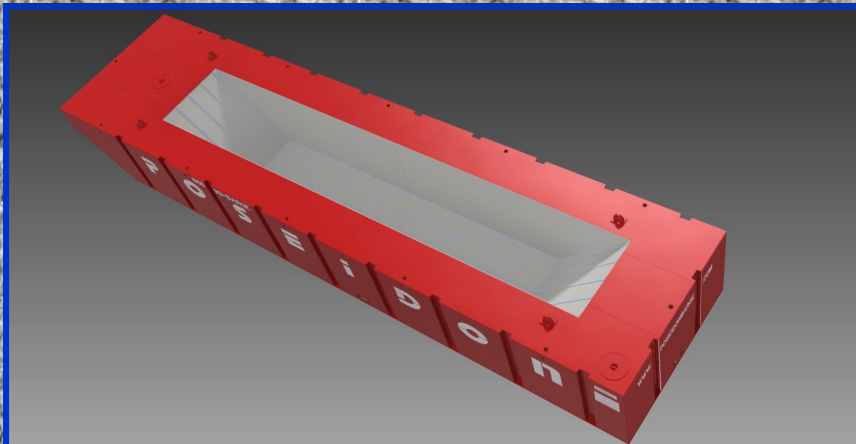

HEAVY DUTY CONSTRUCTION INCLUDES:

- 50'0" Long x 12'0" Wide x 6'0" Tall raked one end
- Physical Shipping Weight 42,000 lbs
- 37 Yard Capacity Hopper
- 1.1' draft empty fresh water
- 4'6" draft fresh water with 42 yds. material
- Two (2) each —18" deck hatches
- Four (4) each 18" Cleats
- Four (4) point lifting eyes for handling with the crane
- 3/8" GR A-36 Steel Sides & end hopper panels.
- 1/4" GR A-36 Steel external panels
- Exterior shell panels are reinforced with 3 x 3 x 1/4" stitch welded angle.
- Five (5) rows of 3" x 1/2" steel ribs on the bottom & sloped end for added protection when digging out with an exc. bucket.

POSEIDON® BARGE

MID-AMERICA FOUNDATION SUPPLY INC d/b/a POSEIDON® BARGE
3101 NEW HAVEN AVE, FORT WAYNE, IN 46803
PH: 866-99-BARGE; FAX 260-424-8635; WEBSITE; www.poseidonbarge.com



Poseidon Barge Hopper

(With P1 Castings)

The Poseidon Hopper Barge is designed for heavy duty use on dredging & rip-rap projects. Ideal for inland river, lakes and pond mechanical dredging projects. The Poseidon Hopper Barge is trucked to the site. Call for lead time & pricing.

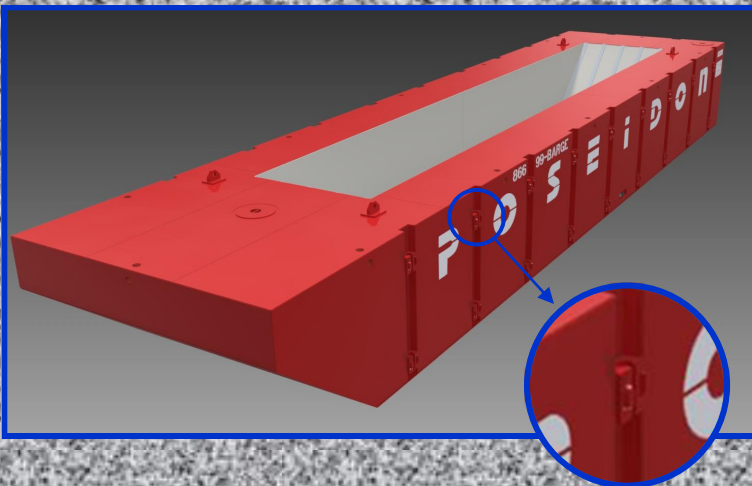
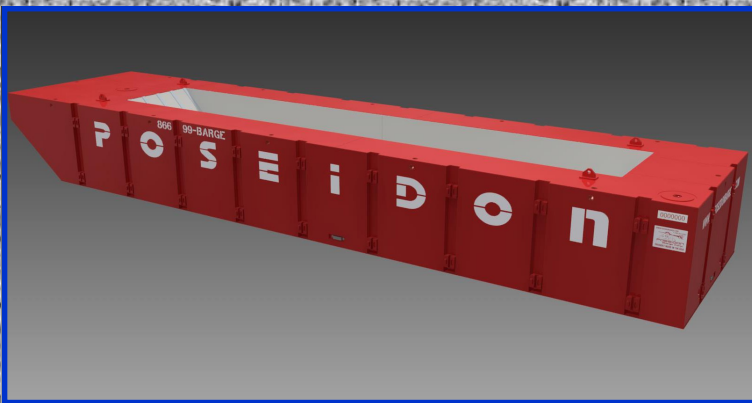
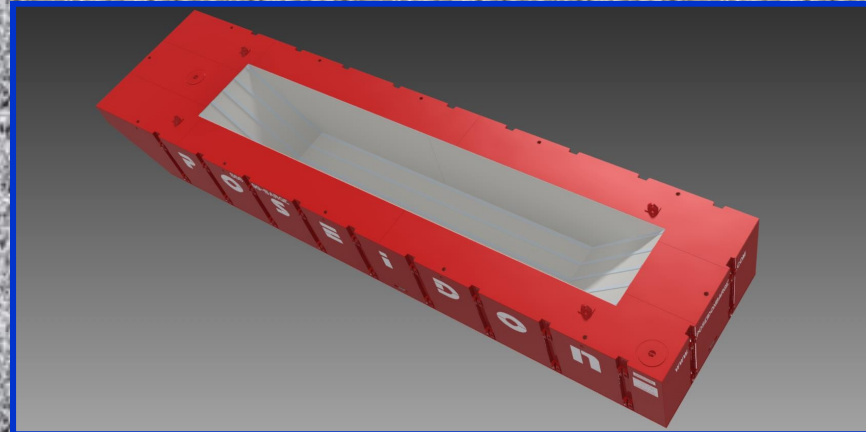

HEAVY DUTY CONSTRUCTION INCLUDES:

- 50'0" Long x 12'0" Wide x 6'0" Tall raked one end
- Physical Shipping Weight 42,000 lbs
- 37 Yard Capacity Hopper
- 1.1' draft empty fresh water
- 4'6" draft fresh water with 42 yds. material
- Two (2) each —18" deck hatches
- Four (4) each 18" Cleats
- Four (4) point lifting eyes for handling with the crane
- 3/8" GR A-36 Steel Sides & end hopper panels.
- 1/4" GR A-36 Steel external panels
- Exterior shell panels are reinforced with 3 x 3 x 1/4" stitch welded angle.
- Five (5) rows of 3" x 1/2" steel ribs on the bottom & sloped end for added protection when digging out with an exc. bucket.
- Using Poseidon P1 Style Connections, the Hopper can be pinned to other Hoppers or the P1 40' x 10' x 5' Sectional Barge.

POSEIDON® BARGE

MID-AMERICA FOUNDATION SUPPLY INC d/b/a POSEIDON® BARGE
3101 NEW HAVEN AVE, FORT WAYNE, IN 46803
PH: 866-99-BARGE; FAX 260-424-8635; WEBSITE; www.poseidonbarge.com