

TROUBLESHOOTING MANUAL

CAT C3.4B ENGINE

FPT INDUSTRIAL

CAT C3.4B Engine Parts

Contact phone: 269 673 1638

Email: EngineParts@HeavyEquipmentRestorationParts.com

Website: www.CATC34B.com

Related website: www.HeavyEquipmentRestorationParts.com

www.FPTIndustrialEngineParts.com

Printed in U.S.A

Acceleration Is Poor or Throttle Response Is Poor _____	4
Alternator Problem - Charging Problem andor Noisy Operation _____	10
Battery Problem _____	13
Component Location _____	15
Configuration Parameters _____	24
Coolant Contains Oil _____	26
Coolant Level Is Low _____	29
Coolant Temperature Is High _____	30
Crankcase Breather Ejects Oil _____	35
Cylinder Is Noisy _____	39
Data Link - Test _____	42
Diagnostic Capabilities _____	47
Diagnostic Trouble Codes _____	49
Diesel Particulate Filter Active Regeneration Occurrence Is Excessive _____	63
Diesel Particulate Filter Active Regeneration Was Interrupted _____	67
Diesel Particulate Filter Collects Excessive Soot _____	70
Diesel Particulate Filter Has Differential Pressure Problem _____	74
Diesel Particulate Filter Regeneration _____	78
Diesel Particulate Filter Temperature Is Low _____	79
ECM - Replace _____	82
ECM Memory - Test _____	84
ECM Software - Install _____	88
Electrical Connectors - Inspect _____	91
Electrical Connectors _____	96
Electrical Power Supply - Test _____	98
Electronic Service Tool Does Not Communicate _____	103
Electronic Service Tools _____	107
Engine Cranks but Does Not Start _____	111
Engine Does Not Crank _____	118

Engine Has Early Wear _____	122
Engine Has Mechanical Noise (Knock) _____	126
Engine Misfires, Runs Rough or Is Unstable _____	130
Engine Monitoring System _____	135
Engine Overspeeds _____	137
Engine Shutdown Occurs Intermittently _____	139
Engine Stalls at Low RPM _____	142
Engine Top Speed Is Not Obtained _____	145
Engine Vibration Is Excessive _____	150
Exhaust Has Excessive Black Smoke _____	153
Exhaust Has Excessive White Smoke _____	158
Exhaust System Contains Coolant _____	163
Exhaust System Contains Oil _____	165
Fuel Consumption Is Excessive _____	168
Fuel Contains Water _____	174
Fuel Rail Pressure Problem _____	177
Fuel Temperature Is High _____	184
General Information _____	185
Glow Plug Starting Aid - Test _____	188
Idle Validation - Test _____	198
Indicator Lamp - Test _____	208
Injector Code - Calibrate _____	212
Injector Data Incorrect - Test _____	215
Injector Solenoid - Test _____	220
Inlet Air Is Restricted _____	228
Intake Manifold Air Pressure Is High _____	230
Intake Manifold Air Pressure Is Low _____	233
Intake Manifold Air Temperature Is High _____	236
Mode Selection - Test _____	240
Motorized Valve - Test _____	246

NRS Mass Flow Rate Problem _____	254
Oil Consumption Is Excessive _____	257
Oil Contains Coolant _____	261
Oil Contains Fuel _____	264
Oil Pressure Is Low _____	268
Oxygen Level - Test _____	273
Power Is Intermittently Low or Power Cutout Is Intermittent _____	282
Power Take-Off - Test _____	286
Relay - Test - ECM Main Relay _____	292
Relay - Test - Start Relay _____	297
Sensor Signal (Analog, Active) - Test - Exhaust Gas Pressure Sensor _____	305
Sensor Signal (Analog, Active) - Test _____	312
Sensor Signal (Analog, Passive) - Test _____	322
Sensor Supply - Test _____	331
Service Information Report _____	337
Service Tool Features _____	339
Solenoid Valve - Test _____	343
Speed Control - Test _____	352
SpeedTiming - Test _____	360
Switch Circuits - Test - Air Filter Restriction Switch _____	369
Switch Circuits - Test - Engine Oil Pressure Switch _____	377
Switch Circuits - Test - Throttle Switch _____	383
System Overview _____	389
Valve Lash Is Excessive _____	391
Valve Position - Test _____	393
Water in Fuel - Test _____	401
Welding Precaution _____	406



Previous Screen



Troubleshooting

C3.4B Engines

Media Number -UENR0611-10

Publication Date -01/02/2015

i06219299

Acceleration Is Poor or Throttle Response Is Poor

SMCS - 1000-035

Probable Causes

- Diagnostic codes
- Parameters in the Electronic Control Module (ECM)
- Throttle Position Sensor/Throttle Switches
- Air intake and exhaust system
- Valve lash
- Turbocharger
- Fuel supply
- Low compression (cylinder pressure)
- Electronic unit injectors
- Individual malfunctioning cylinder

Recommended Actions

NOTICE

Do not crank the engine continuously for more than 30 seconds. Allow the starting motor to cool for two minutes before cranking the engine again.

Note: The procedures have been listed in order of probability. Complete the procedures in order.

Note: If the problem only occurs under certain conditions, test the engine under those conditions. Examples of certain conditions are high engine speed, full load, and engine operating temperature. Troubleshooting the symptoms under other conditions can give misleading results.

Table 1

Troubleshooting Test Steps	Values	Results
<p>1. Diagnostic Codes</p> <p>Note: Certain diagnostic codes may cause poor performance.</p> <p>A. Use the electronic service tool to check for active or logged diagnostic codes.</p>	<p>Engine Derate or Diagnostic Codes</p>	<p>Result: A diagnostic code is present.</p> <p>Repair: Troubleshoot the diagnostic code. Refer to Troubleshooting, "Diagnostic Trouble Codes".</p> <p>Result: A diagnostic code is not present. Proceed to Test Step 2.</p>
<p>2. Parameters in the Electronic Control Module (ECM)</p> <p>A. Use the electronic service tool to verify that the correct parameters are being used. Refer to Troubleshooting, "Configuration Parameters" for additional information.</p>	<p>Parameters</p>	<p>Result: The parameters are not correct.</p> <p>Repair: Input the correct parameters. Refer to Troubleshooting, "Configuration Parameters" for additional information.</p> <p>Result: The parameters are correct. Proceed to Test Step 3.</p>
<p>3. Throttle Position Sensor/Throttle Switches</p> <p>A. Turn the start switch to the ON position.</p> <p>B. Run the engine until the speed is equal to the maximum no-load speed.</p> <p>C. Use the electronic service tool to make sure that the throttle is set to reach the maximum no-load speed.</p>	<p>Electrical connections</p>	<p>Result: The throttle response is not as expected.</p> <p>Repair: If the maximum no-load speed cannot be obtained refer to Troubleshooting, "Switch Circuits - Test (Throttle Switch)" and Troubleshooting, "Mode Selection - Test".</p> <p>If the engine speed is erratic</p>

		<p>refer to Troubleshooting, "Speed Control - Test".</p> <p>Result: All responses are normal.</p> <p>Proceed to Test Step 4.</p>
<p>4. Air Intake and Exhaust System</p> <p>A. Observe the engine warning lamp. Check for an air filter restriction indicator, if equipped. Replace plugged air filters. Refer to the Operation and Maintenance Manual.</p> <p>B. Check the air inlet and exhaust system for restrictions and/or leaks. Refer to Systems Operation/Testing and Adjusting, "Air Inlet and Exhaust System - Inspect".</p>	<p>Restrictions</p>	<p>Result: There are restrictions in the air inlet or exhaust system.</p> <p>Repair: Make the necessary repairs, Refer to Systems Operation/Testing and Adjusting, "Air Inlet and Exhaust System - Inspect" for additional information.</p> <p>Result: There are no restrictions in the air inlet or exhaust system.</p> <p>Proceed to Test Step 5.</p>
<p>5. Valve Lash</p> <p>Note: The valve lash can affect the performance of the engine.</p> <p>A. Check the valve lash. Refer to Systems Operation, Testing and Adjusting, "Engine Valve Lash - Inspect".</p>	<p>Valve lash</p>	<p>Result: The valve lash is not correct.</p> <p>Repair: Make any necessary repairs. Refer to Systems Operation, Testing and Adjusting, "Engine Valve Lash - Inspect".</p> <p>Result: The valve lash is correct.</p> <p>Proceed to Test Step 6.</p>
<p>7. Turbocharger</p> <p>Note: The turbocharger that is installed on the engine is a nonserviceable item. If any mechanical fault exists, then the faulty turbocharger must be replaced.</p> <p>A. Ensure that the mounting bolts for the turbocharger are tight.</p>	<p>Turbocharger</p>	<p>Result: There is a fault on the turbocharger.</p> <p>Repair: Repair the turbocharger or replace the turbocharger. Refer to Disassembly and Assembly, "Turbocharger - Remove" and Disassembly and Assembly, "Turbocharger - Install".</p>

<p>B. Check that the oil drain for the turbocharger is not blocked or restricted.</p> <p>C. Check that the compressor housing for the turbocharger is free of dirt and debris. Make sure that the housing is not damaged.</p> <p>D. Check that the turbine housing for the turbocharger is free of dirt and debris. Make sure that the housing is not damaged.</p> <p>E. Check that the turbine blades rotate freely in the turbocharger.</p> <p>F. Ensure that the wastegate on the turbocharger is adjusted correctly. Refer to Systems Operation, Testing, and Adjusting, "Turbocharger - Inspect". If the wastegate actuator is faulty, replace the turbocharger. Refer to Disassembly and Assembly, "Turbocharger - Remove" and Disassembly and Assembly, "Turbocharger - Install".</p>		<p>Result: The turbocharger is OK.</p> <p>Proceed to Test Step 8.</p>
<p>8. Fuel Supply</p> <p>A. Visually check the fuel level in the fuel tank. Do not rely on the fuel gauge only.</p> <p>B. Ensure that the vent in the fuel cap is not filled with debris.</p> <p>C. Ensure that the fuel supply valve (if equipped) is in the full OPEN position.</p> <p>D. If the temperature is below 0 °C (32 °F), check for solidified fuel (wax).</p> <p>E. Check the primary filter/water separator for water in the fuel.</p> <p>F. Check for fuel supply lines that are restricted.</p> <p>G. Check that the low-pressure fuel lines are tight and secured properly.</p> <p>H. Replace the primary and secondary fuel filters.</p> <p>I. Check the diesel fuel for contamination. Refer to Systems Operation, Testing, and</p>	<p>Fuel system</p>	<p>Result: The fuel supply is not OK.</p> <p>Repair: Repair the fuel system or replace the fuel system components, as necessary.</p> <p>Result: The fuel supply is OK.</p> <p>Proceed to Test Step 9.</p>

<p>Adjusting, "Fuel Quality - Test".</p> <p>J. Check for air in the fuel system. Refer to Systems Operation, Testing, and Adjusting, "Air in Fuel - Test".</p> <p>K. Ensure that the fuel system has been primed. Refer to Systems Operation, Testing, and Adjusting, "Fuel System - Prime".</p>		
<p>9. Low Compression (Cylinder Pressure)</p> <p>A. Perform a compression test. Refer to Systems Operation, Testing, and Adjusting, "Compression - Test ".</p>	<p>Cylinder compression</p>	<p>Result: The results of the compression test are outside the specifications.</p> <p>Repair: Investigate the cause and rectify any faults.</p> <p>Note: Possible causes of low compression are shown in the following list:</p> <ul style="list-style-type: none"> · Loose glow plugs · Faulty piston · Faulty piston rings · Worn cylinder bores · Worn valves · Faulty cylinder head gasket · Damaged cylinder head <p>Result: The results of the compression test are OK.</p> <p>Proceed to Test Step 10.</p>
<p>10. Electronic Unit Injectors</p> <p>A. Use the electronic service tool to check for active diagnostic codes that relate to the electronic unit injectors.</p>	<p>Diagnostic codes</p>	<p>Result: There are active diagnostic codes relating to the fuel injectors.</p> <p>Repair: Troubleshoot the active diagnostic codes.</p> <p>Refer to Troubleshooting, "Diagnostic Trouble Codes".</p> <p>Result: All injectors are OK.</p> <p>Proceed to Test Step 11.</p>

11. Individual Malfunctioning Cylinders

A. With the engine speed at a fast idle, use the electronic service tool to perform the manual "Cylinder Cut Out Test".

As each cylinder is cut out, listen for a change in the sound from the engine. When a cylinder is cut out, there should be a noticeable change in the sound of the engine.

If a change in the sound of the engine is not noted, the isolated cylinder is not operating under normal conditions. If the isolation of a cylinder results in a change in the sound that is less noticeable, the cylinder may be operating below normal performance.

Cylinders

Result: The test indicates a faulty cylinder.

Repair: Investigate the cause of the fault on any cylinder that is not operating. Investigate the cause of the fault on any cylinder that is operating below normal performance.

Result: The test indicates that all cylinders are OK.

CAT C3.4B Engine Parts

Contact phone: 269 673 1638

Email: EngineParts@HeavyEquipmentRestorationParts.com

Alternate email: engineparts2@gmail.com

Website: www.CATC34B.com

Related website: www.HeavyEquipmentRestorationParts.com

www.FPTIndustrialEngineParts.com



Previous Screen



Troubleshooting
C3.4B Engines

Media Number -UENR0611-10

Publication Date -01/02/2015

i06221197

Alternator Problem - Charging Problem and/or Noisy Operation

SMCS - 1405-035

Probable Causes

- Alternator
- Charging Circuit

Recommended Actions

Note: The procedures have been listed in order of probability. Complete the procedures in order.

Table 1

Troubleshooting Test Steps	Values	Results
<p>1. Condition of the Alternator Drive Belts</p> <p>A. Inspect the condition of the alternator drive belts.</p> <p>B. Check the belt tension. If the engine is equipped with an automatic belt tensioner, check the automatic belt tensioner.</p> <p>Excessive belt tension can result in damage to the alternator.</p>	<p>Drive belt</p>	<p>Result: The alternator drive belts are in good condition and the belt tension is correct.</p> <p>Proceed to Test Step 2.</p> <p>Result: The alternator drive belts are not in good condition or the belt tension is incorrect.</p> <p>Repair: If the alternator drive belts are worn or damaged, replace the belts. Refer to Disassembly and Assembly for the correct procedure.</p>

		If necessary, replace the automatic belt tensioner. Refer to Disassembly and Assembly for the correct procedure.
<p>2. Condition of the Alternator Drive Pulley</p> <p>A. Check the condition of the alternator drive pulley. Look for deep grooves that have been worn into the pulley by the belt. Check that the nut for the pulley has not become loose.</p>	Alternator Drive Pulley	<p>Result: There is excessive wear on the alternator drive pulley.</p> <p>Repair: Replace the pulley.</p> <p>Result: The alternator drive pulley nut was loose.</p> <p>Repair: Tighten the nut.</p> <p>Result: There is not excessive wear on the alternator drive pulley.</p> <p>Proceed to Test Step 3.</p>
<p>3. Wear of the Alternator Bearings</p> <p>A. Check the alternator bearings for signs of wear.</p>	Alternator bearings	<p>Result: The alternator bearings are OK.</p> <p>Proceed to Test Step 4.</p> <p>Result: The alternator bearings are not OK.</p> <p>Repair: Repair the alternator or replace the alternator, as needed. Refer to Disassembly and Assembly for the correct procedure.</p>
<p>4. Operation of the Alternator or Regulator</p> <p>A. Verify that the alternator or the regulator is operating correctly. Refer to Systems Operation, Testing and Adjusting, "Alternator - Test" for the proper testing procedures.</p>	Regulator and alternator	<p>Result: The regulator and alternator are operating properly.</p> <p>Proceed to Test Step 5.</p> <p>Result: The regulator and alternator are not operating properly.</p> <p>Repair: Repair the alternator and regulator or replace the alternator and regulator, as needed. Refer to Disassembly and Assembly for the</p>

		correct procedure.
5. Inspection of the Charging Circuit A. Inspect the battery cables, wiring, and connections in the charging circuit.	Charging circuit	Result: The charging circuit is not working properly. Repair: Clean all connections and tighten all connections. Replace any faulty parts.

CAT C3.4B Engine Parts

Contact phone: 269 673 1638

Email: EngineParts@HeavyEquipmentRestorationParts.com

Alternate email: engineparts2@gmail.com

Website: www.CATC34B.com

Related website: www.HeavyEquipmentRestorationParts.com

www.FPTIndustrialEngineParts.com

Service Information System

Previous Screen



Troubleshooting

C3.4B Engines

Media Number -UENR0611-10

Publication Date -01/02/2015

i06221204

Battery Problem

SMCS - 1401-035

Probable Causes

- Charging circuit
- Battery
- Auxiliary device

Recommended Actions

Complete the procedure in the order in which the steps are listed.

Table 1

Troubleshooting Test Steps	Values	Results
<p>1. Charging Circuit</p> <p>A. Check that the battery charging circuit is operating correctly. Refer to Troubleshooting, "Alternator Problem".</p>	Charging circuit	<p>Result: The charging circuit is not OK.</p> <p>Repair: Repair the charging circuit, as necessary.</p> <p>Result: The charging circuit is OK.</p> <p>Proceed to Test Step 2.</p>
<p>2. Battery</p> <p>A. Verify that the battery is no longer able to hold a charge. Refer to Systems Operation/Testing and</p>	Battery	<p>Result: The battery is not OK.</p> <p>Repair: Replace the battery. Refer to the Operation and Maintenance Manual, "Battery - Replace".</p>

Adjusting, "Battery - Test".		<p>Result: The battery is OK.</p> <p>Proceed to Test Step 3.</p>
<p>3. Auxiliary Device</p> <p>A. Check if an auxiliary device has drained the battery by being left in the ON position.</p>	Auxiliary Device	<p>Result: The battery has been drained by an auxiliary device being left in the ON position.</p> <p>Repair: Charge the battery. Verify that the battery is able to maintain a charge. Refer to Systems Operation/Testing and Adjusting for the correct procedure.</p> <p>Result: The battery has not been drained by an auxiliary device being left in the ON position.</p> <p>Contact the Dealer Solutions Network (DSN).</p>



Previous Screen



Troubleshooting
C3.4B Engines

Media Number -UENR0611-10

Publication Date -01/02/2015

i05980345

Component Location

SMCS - 1000; 1900

Electronic Control Circuit Diagram

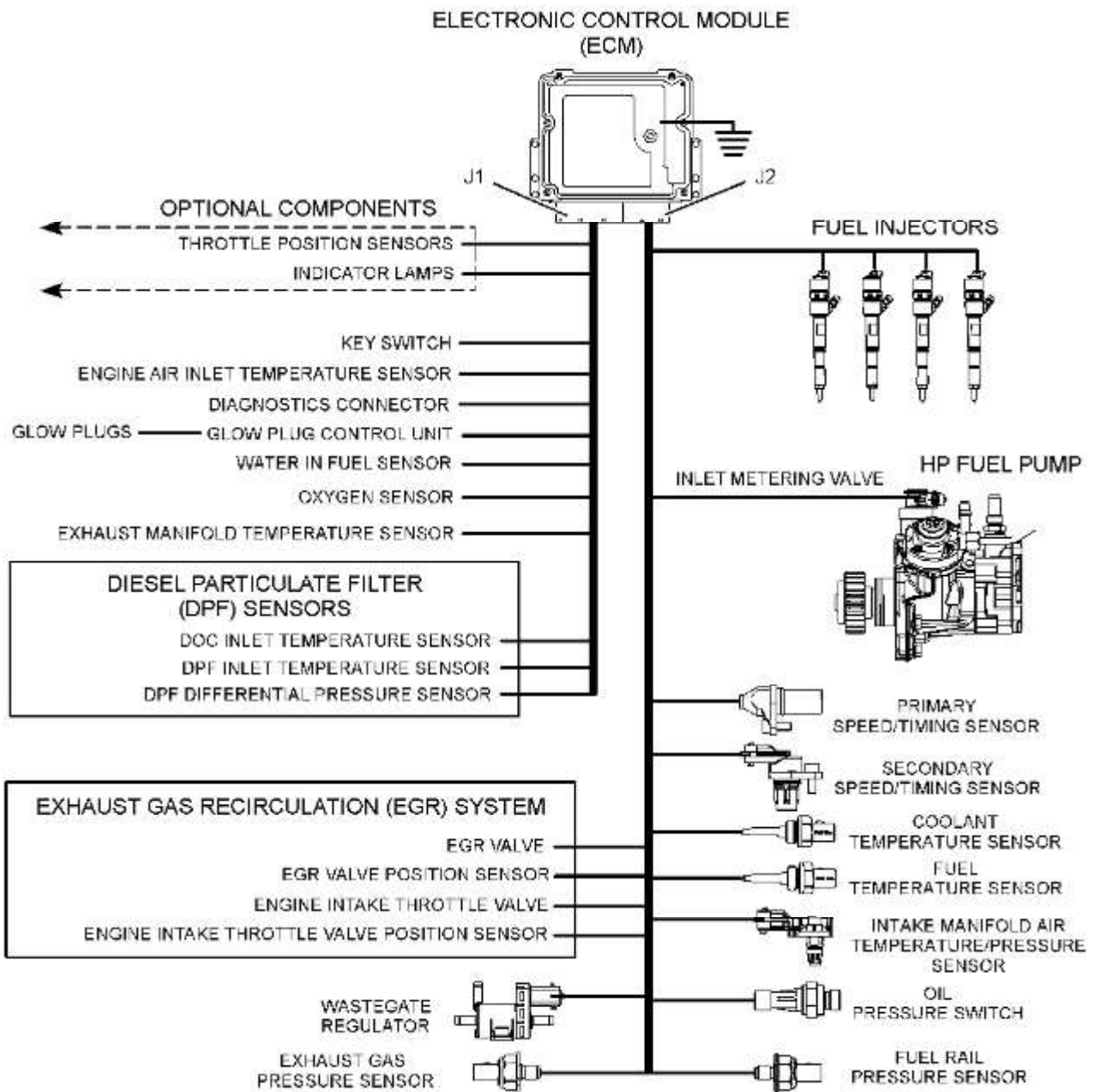

Illustration 1

g037461

Electronic control circuit diagram for the greater than 56 kW (75 hp) C3.4B engine

CAT C3.4B Engine Parts

Contact phone: 269 673 1638

Email: EngineParts@HeavyEquipmentRestorationParts.com

Alternate email: engineparts2@gmail.com

Website: www.CATC34B.com

Related website: www.HeavyEquipmentRestorationParts.com

www.FPTIndustrialEngineParts.com

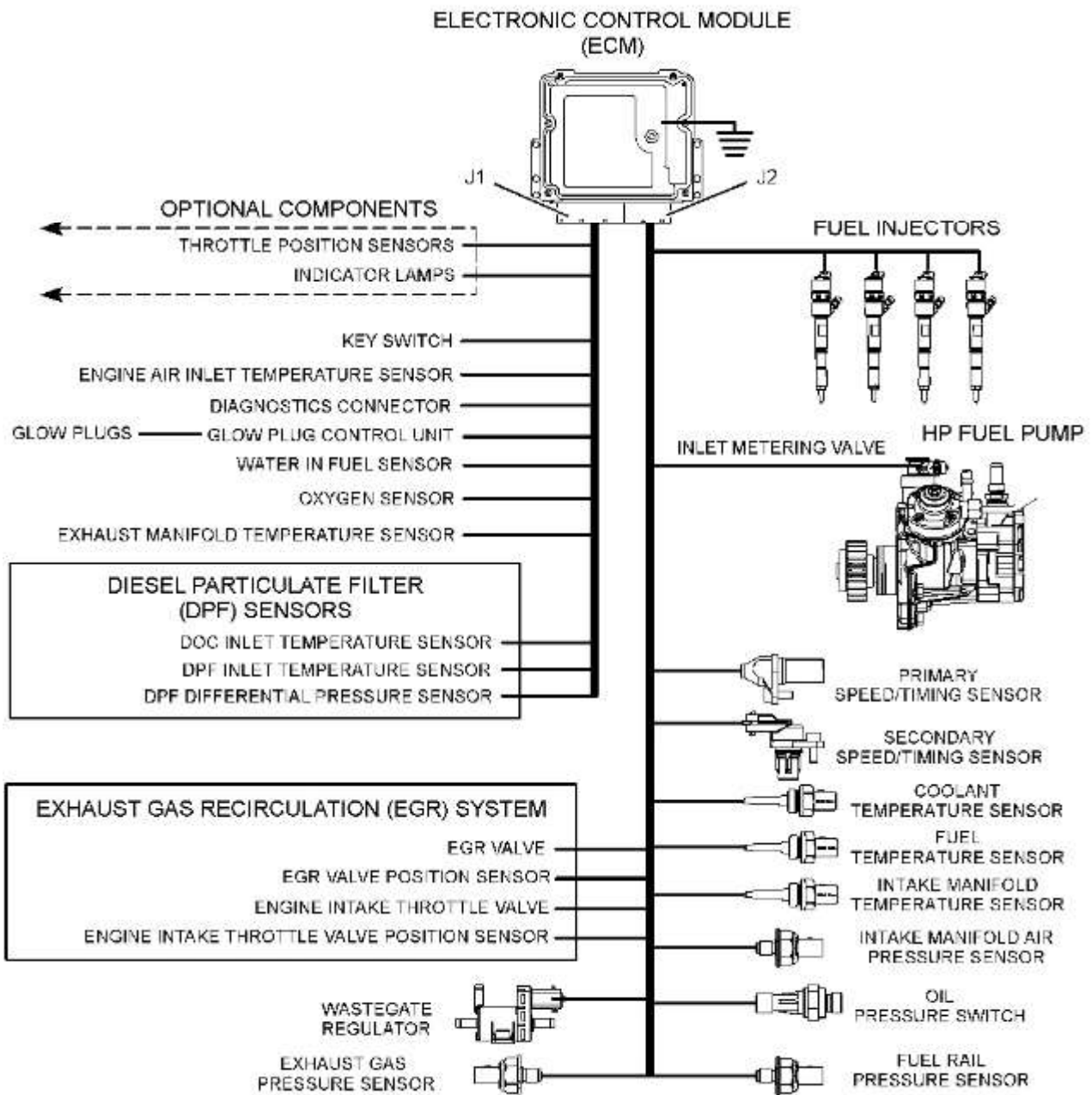

Illustration 2

g037461

Electronic control circuit diagram for the less than 56 kW (75 hp) C3.4B engine equipped with a wall flow DPF

CAT C3.4B Engine Parts

Contact phone: 269 673 1638

Email: EngineParts@HeavyEquipmentRestorationParts.com

Alternate email: engineparts2@gmail.com

Website: www.CATC34B.com

Related website: www.HeavyEquipmentRestorationParts.com

www.FPTIndustrialEngineParts.com

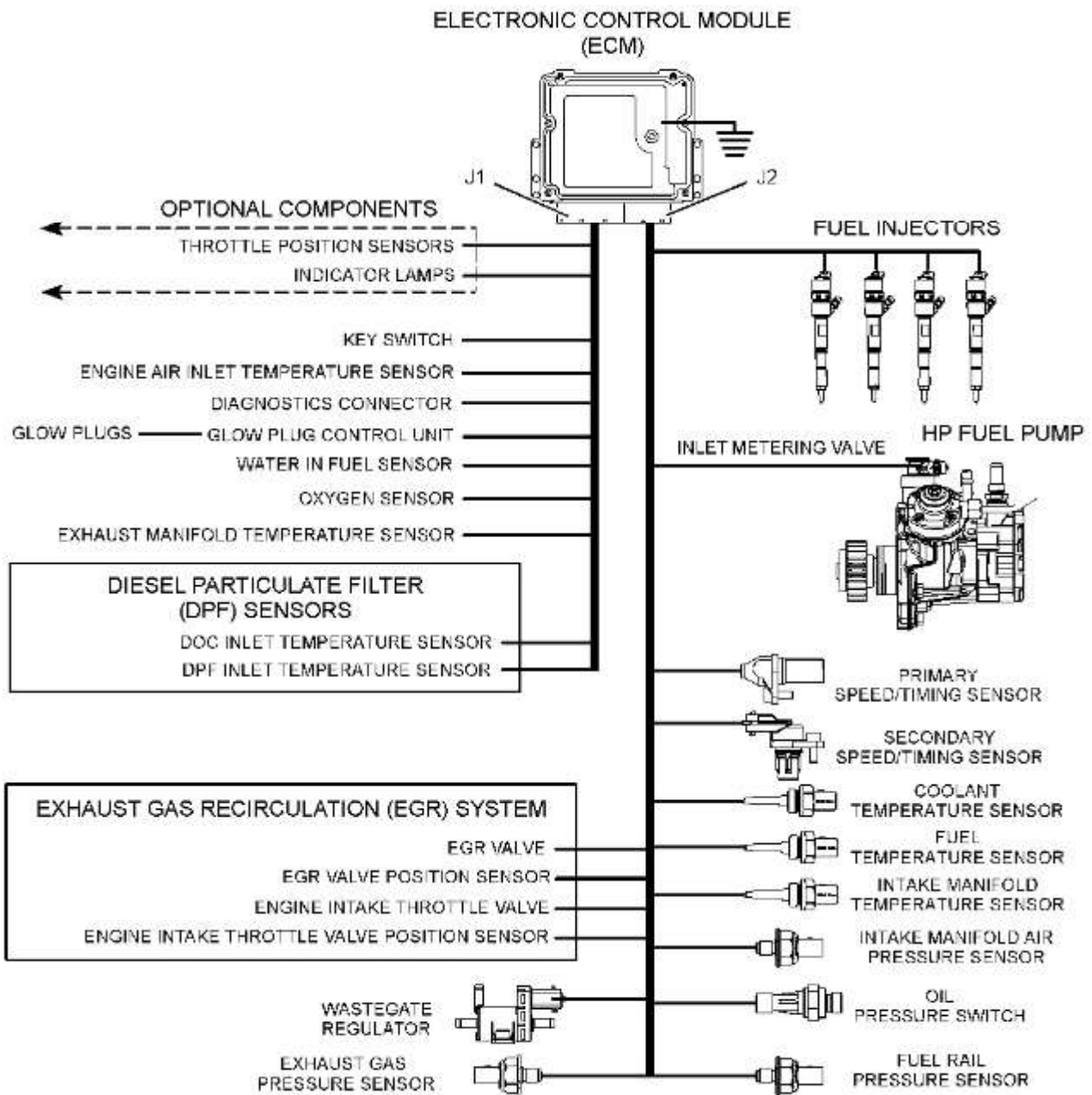

Illustration 3

g037461:

Electronic control circuit diagram for the less than 56 kW (75 hp) C3.4B engine equipped with a through-flow DPF

C3.4B Engine

CAT C3.4B Engine Parts

Contact phone: 269 673 1638

Email: EngineParts@HeavyEquipmentRestorationParts.com

Alternate email: engineparts2@gmail.com

Website: www.CATC34B.com

Related website: www.HeavyEquipmentRestorationParts.com

www.FPTIndustrialEngineParts.com

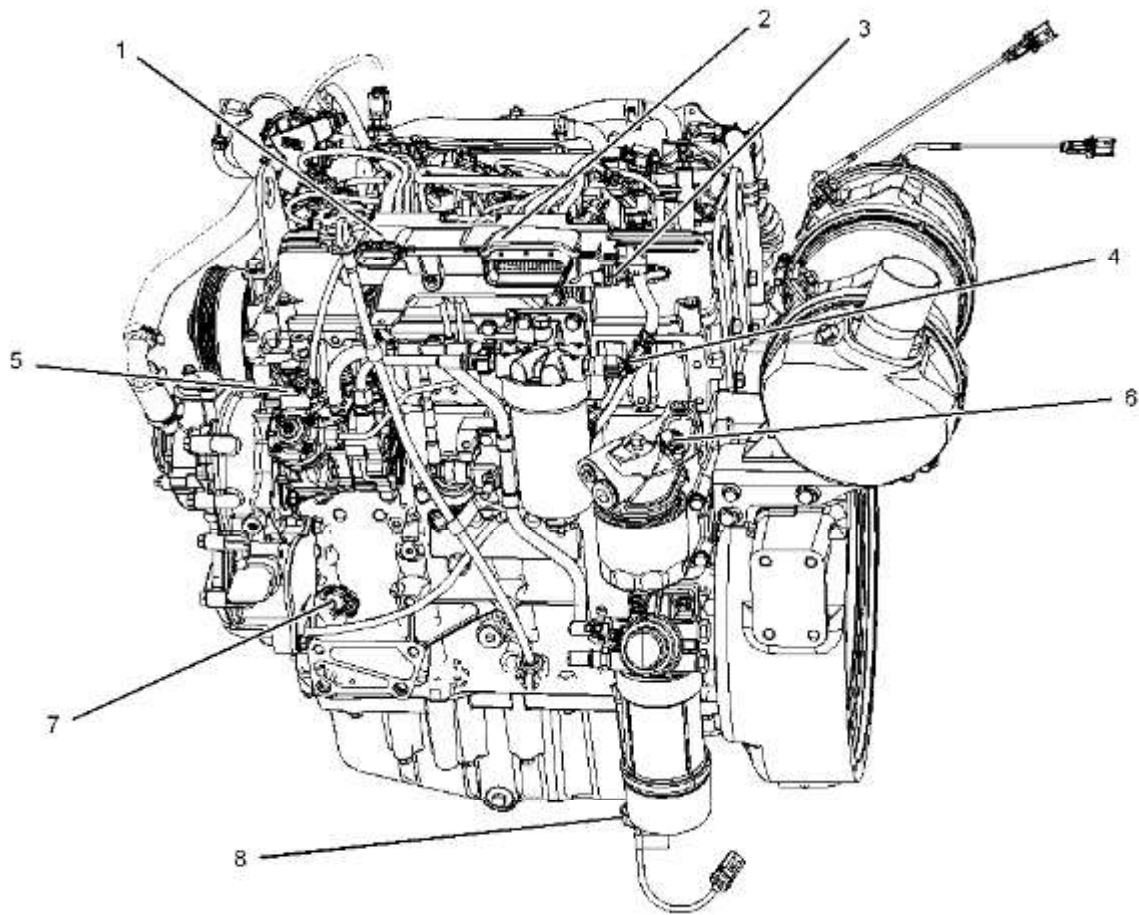

Illustration 4

g027379

Sensors and electrical connector locations on the left side of the C3.4B engine (typical example)

- (1) 10-pin engine interface connector (optional)
 - (2) 62-pin engine interface connector (optional)
 - (3) Fuel rail pressure sensor
 - (4) Fuel temperature sensor
 - (5) High-pressure fuel pump inlet metering valve
 - (6) Oil pressure switch
 - (7) Primary speed/timing sensor (crankshaft)
 - (8) Water In Fuel (WIF) sensor
-

CAT C3.4B Engine Parts

Contact phone: 269 673 1638

Email: EngineParts@HeavyEquipmentRestorationParts.com

Alternate email: engineparts2@gmail.com

Website: www.CATC34B.com

Related website: www.HeavyEquipmentRestorationParts.com

www.FPTIndustrialEngineParts.com

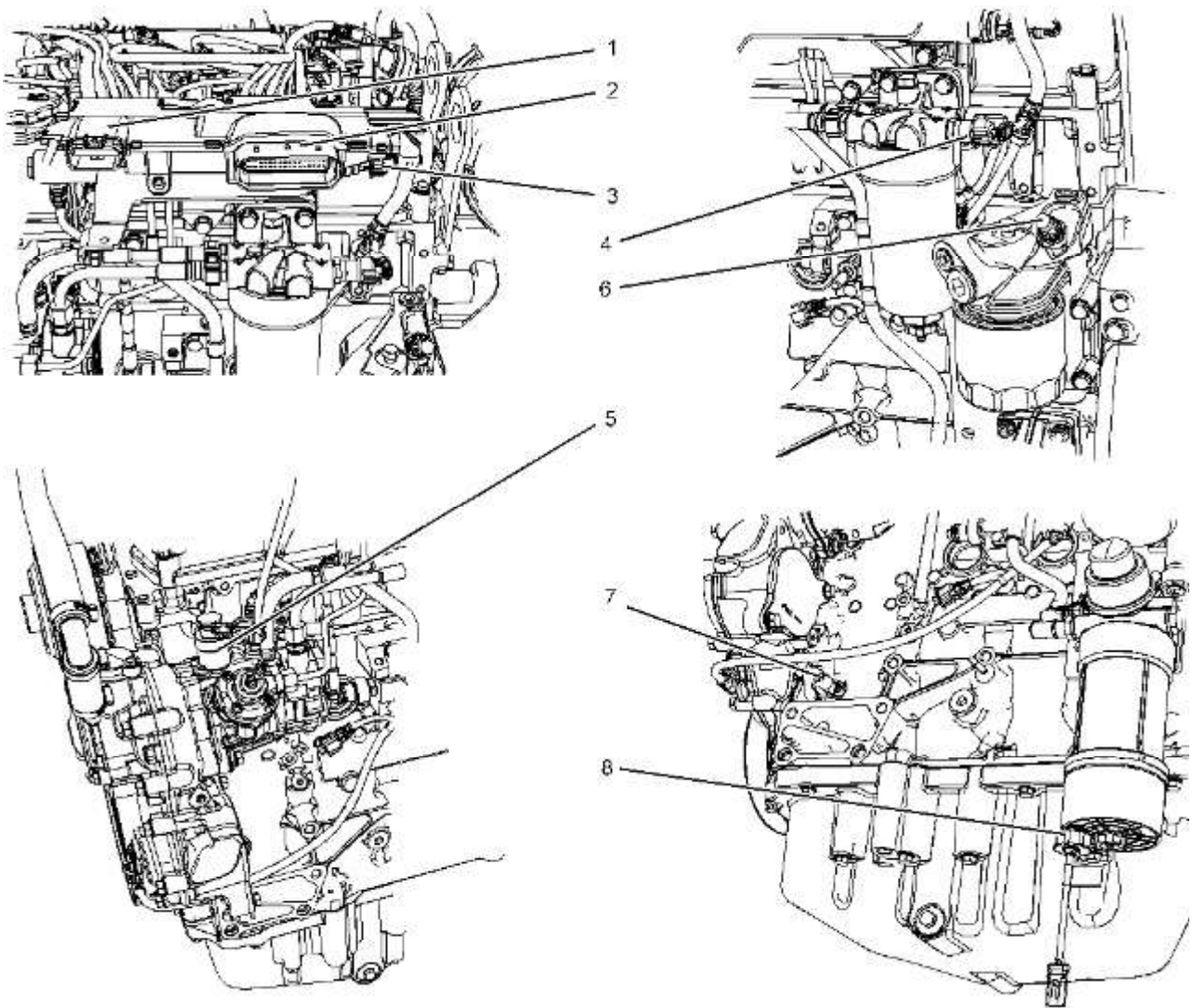

Illustration 5

g027379

Close up views of the sensor locations on the left side of the C3.4B engine (typical example)

- (1) 10-pin engine interface connector (optional)
- (2) 62-pin engine interface connector (optional)
- (3) Fuel rail pressure sensor
- (4) Fuel temperature sensor
- (5) High-pressure fuel pump inlet metering valve
- (6) Oil pressure switch
- (7) Primary speed/timing sensor (crankshaft)
- (8) Water In Fuel (WIF) sensor

CAT C3.4B Engine Parts

Contact phone: 269 673 1638

Email: EngineParts@HeavyEquipmentRestorationParts.com

Alternate email: engineparts2@gmail.com

Website: www.CATC34B.com

Related website: www.HeavyEquipmentRestorationParts.com

www.FPTIndustrialEngineParts.com

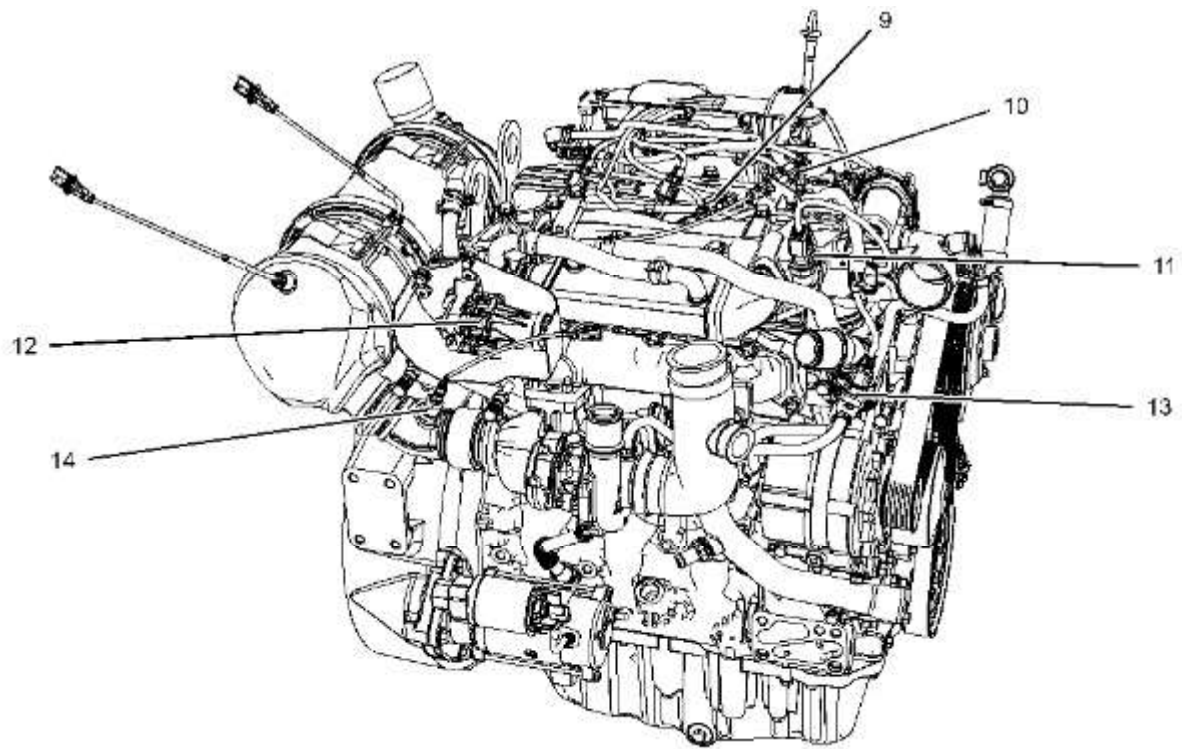
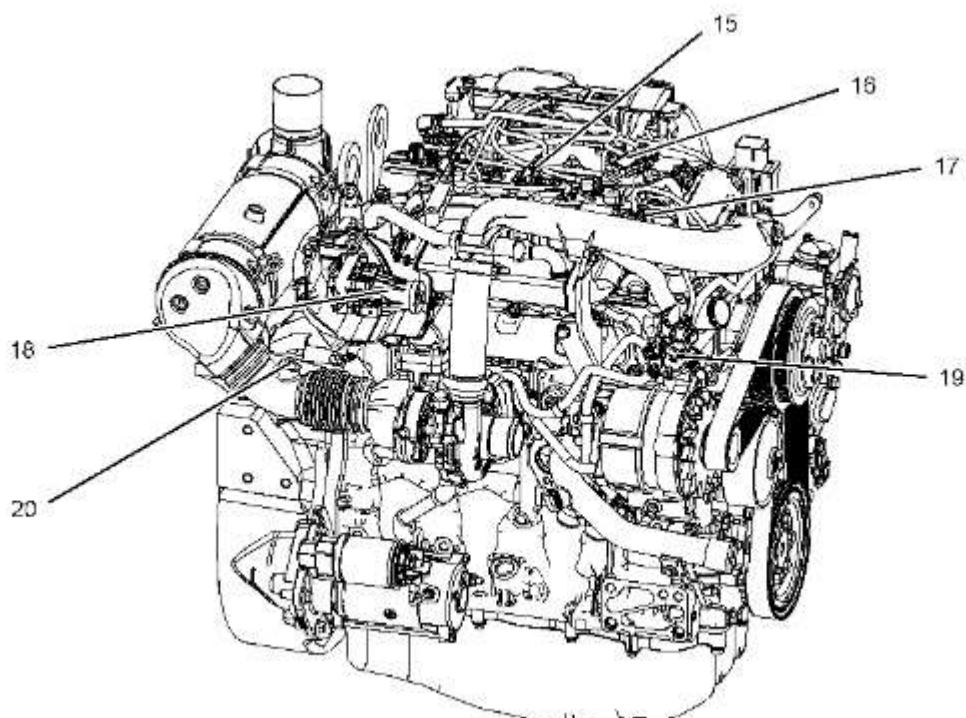

Illustration 6

g027379:

Sensors and electrical connector locations on the right side of the greater than 56 kW (75 hp) C3.4B engine (typical example)

- (9) Intake manifold air pressure and temperature sensor
- (10) Exhaust temperature sensor connector
- (11) Exhaust gas pressure sensor
- (12) NOx Reduction System (NRS) valve
- (13) Wastegate regulator
- (14) Oxygen sensor



Sensors and electrical connector locations on the right side of the less than 56 kW (75 hp) C3.4B engine (typical example)

- (15) Intake manifold temperature sensor
- (16) Intake manifold pressure sensor
- (17) Exhaust gas pressure sensor
- (18) NOx Reduction System (NRS) valve
- (19) Wastegate regulator
- (20) Oxygen sensor

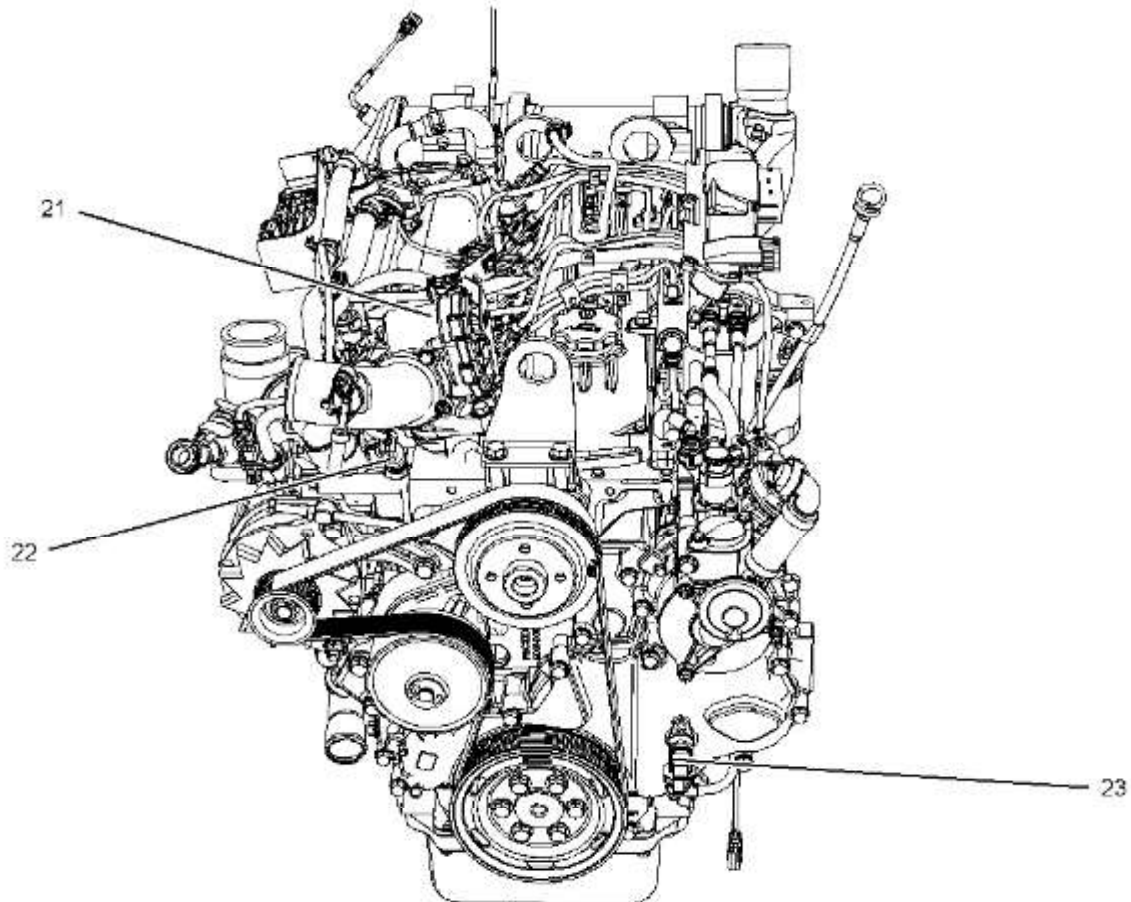

Sensors and electrical connection locations on the front of the C3.4B engine (typical example)

- (21) Intake throttle valve
- (22) Coolant temperature sensor
- (23) Secondary (camshaft) speed/timing sensor

Clean Emissions Module (CEM)

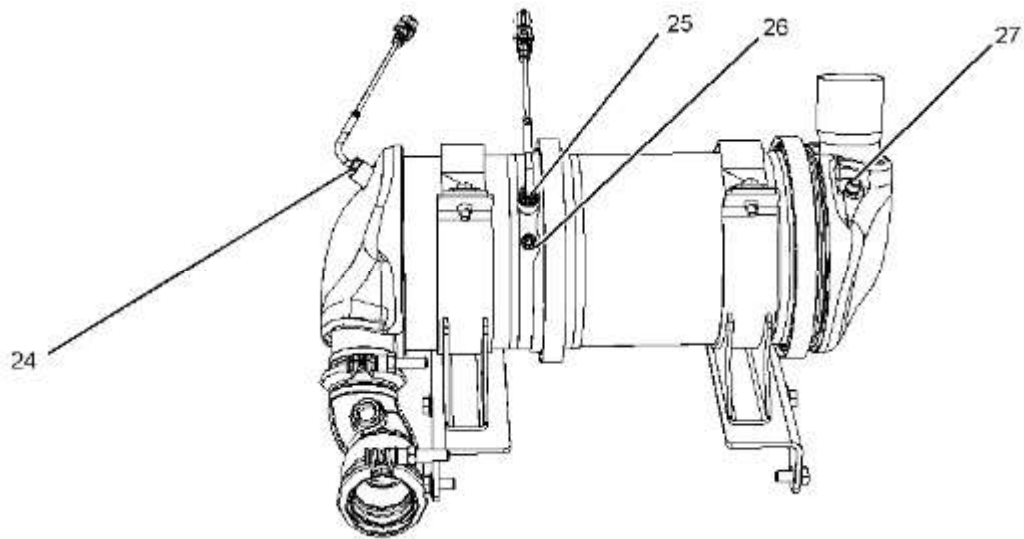

Illustration 9

g033560:

Typical view of the sensor locations on the CEM on C3.4B engines equipped with a wall-flow DPF (typical example)

- (24) Diesel Oxidation Catalyst (DOC) inlet temperature sensor
- (25) Diesel Particulate Filter (DPF) inlet temperature sensor
- (26) Inlet connection for the DPF differential pressure sensor
- (27) Outlet connection for the DPF differential pressure sensor

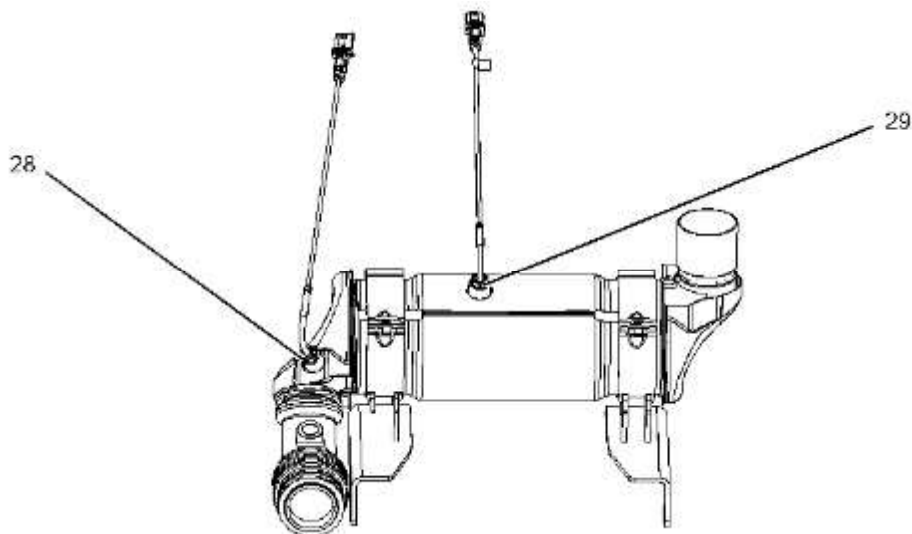

Illustration 10

g033560:

Typical view of the sensor locations on the CEM on C3.4B engines equipped with a through-flow DPF (typical example)

- (28) Diesel Oxidation Catalyst (DOC) inlet temperature sensor
- (29) Diesel Particulate Filter (DPF) inlet temperature sensor

CAT C3.4B Engine Parts Contact phone: 269 673 1638
Email: EngineParts@HeavyEquipmentRestorationParts.com
Alternate email: engineparts2@gmail.com
Website: www.CATC34B.com
Related website: www.HeavyEquipmentRestorationParts.com
www.FPTIndustrialEngineParts.com



Troubleshooting

C3.4B Engines

Media Number -UENR0611-10

Publication Date -01/02/2015

i05982913

Configuration Parameters

SMCS - 1900

The electronic service tool can be used to view certain parameters that can affect the operation of the engine. The electronic service tool can also be used to change certain parameters. Some parameters cannot be changed and some applications do not allow any changes to the programmable monitoring system. The parameters are stored in the Electronic Control Module (ECM).

The parameters are divided into two different types:

Customer Specified Parameters - Customer specified parameters can be changed using the electronic service tool.

System Configuration Parameters - System configuration parameters affect the emissions of the engine or the power of the engine. Factory passwords may be required to change the values of system configuration parameters.

1. Connect to the electronic service tool.
2. Select the Service tab.
3. Select the Configuration tab to view the configuration parameters.

If an ECM is replaced, the appropriate parameters must be copied from the old ECM. Refer to Troubleshooting, "ECM Software - Install" or Troubleshooting, "ECM - Replace".

NOTICE

Changing the parameters during engine operation can cause the engine to operate erratically and can cause engine damage.

Only change the settings of the parameters when the engine is STOPPED.



Previous Screen



Troubleshooting
C3.4B Engines

Media Number -UENR0611-10

Publication Date -01/02/2015

i06221207

Coolant Contains Oil

SMCS - 1348-035; 1395-035

Probable Causes

- Engine oil cooler
- Cylinder head gasket
- Cylinder head
- Cylinder block

Recommended Actions

Complete the procedure in the order in which the steps are listed.

Table 1

Troubleshooting Test Steps	Values	Results
<p>1. Engine Oil Cooler</p> <p>A. Drain the coolant from the cooling system. Drain the lubricating oil from the engine oil cooler. Refer to the Operation and Maintenance Manual for more information.</p> <p>B. Check for leaks in the engine oil cooler. Refer to Systems Operation, Testing, and Adjusting, "Cooling System" for the proper procedure.</p>	<p>Oil Cooler</p>	<p>Result: A leak is found in the engine oil cooler.</p> <p>Repair: Install a new oil cooler. Refer to Disassembly and Assembly, "Engine Oil Cooler - Remove" and Disassembly and Assembly, "Engine Oil Cooler - Install" for the correct procedure.</p> <p>Flush the cooling system. Refer to the Operation and Maintenance Manual for the correct procedure. Refill the cooling system with the correct coolant. Refer to</p>

		<p>the Operation and Maintenance Manual for the recommended coolant and capacities.</p> <p>Refill the engine with the proper oil after the leak has been repaired. Refer to the Operation and Maintenance Manual for the correct oil capacities and viscosity.</p> <p>Result: A leak was not found in the engine oil cooler.</p> <p>Proceed to Test Step 2.</p>
<p>2. Cylinder Head Gasket</p> <p>A. Remove the cylinder head. Refer to Disassembly and Assembly, "Cylinder Head - Remove".</p> <p>B. Inspect the cylinder head gasket for faults and any signs of leakage.</p>	<p>Cylinder head gasket</p>	<p>Result: The cylinder head gasket does not show signs of damage or leakage.</p> <p>Repair: Install a new cylinder head gasket and install the cylinder head. Refer to Disassembly and Assembly, "Cylinder Head - Install" .</p> <p>Result: The cylinder head gasket shows signs of damage or leakage.</p> <p>Proceed to Test Step 3.</p>
<p>3. Cylinder Head</p> <p>A. Check for cracks in the cylinder head. Perform a leak test on the cylinder head. Refer to System Operation, Testing and Adjusting, "Cylinder Head - Inspect" for the correct procedure.</p>	<p>Cylinder head</p>	<p>Result: A fault is found in the cylinder head.</p> <p>Repair: Repair the cylinder head or replace the cylinder head. Install the cylinder head. Refer to Disassembly and Assembly, "Cylinder Head - Install".</p> <p>Result: A fault is not found in the cylinder head.</p> <p>Proceed to Test Step 4.</p>
<p>4. Cylinder Block</p> <p>A. Inspect the top face of the cylinder block for faults and signs of leakage. Refer to Systems Operation, Testing, and Adjusting, "Cylinder Block - Inspect" for the correct procedure.</p>	<p>Cylinder block</p>	<p>Result: A fault is found in the cylinder block.</p> <p>Repair: Repair the cylinder block or replace the cylinder block. Inspect the top deck. Refer to the Reuse and Salvage Guidelines for the proper inspection procedure.</p>

		<p>Result: No fault is found in the cylinder block.</p>
--	--	--

		<p>Repair: Install the cylinder head. Refer to Disassembly and Assembly, "Cylinder Head - Install".</p>
--	--	--

CAT C3.4B Engine Parts

Contact phone: 269 673 1638

Email: EngineParts@HeavyEquipmentRestorationParts.com

Alternate email: engineparts2@gmail.com

Website: www.CATC34B.com

Related website: www.HeavyEquipmentRestorationParts.com

www.FPTIndustrialEngineParts.com

[Previous Screen](#)

Troubleshooting

C3.4B Engines

Media Number -UENR0611-10

Publication Date -01/02/2015

i05989049

Coolant Level Is Low

SMCS - 1395-035

Note: On engines equipped with a Diesel Exhaust Fluid (DEF) system, the DEF tank requires coolant flow around the tank. The coolant diverter valve will turn the flow to the DEF tank on or off. If the coolant system is filled when the coolant diverter valve is CLOSED , the coolant level will drop when the coolant diverter valve is opened. This situation does not necessarily indicate a fault.

Inspect the cooling system for leaks. Refer to Systems Operation, Testing and Adjusting, "Cooling System - Test" for the correct procedure.



Previous Screen



Troubleshooting
C3.4B Engines

Media Number -UENR0611-10

Publication Date -01/02/2015

i06221217

Coolant Temperature Is High

SMCS - 1395-035

This procedure covers the following diagnostic codes:

Table 1

Diagnostic Trouble Codes for High Coolant Temperature		
J1939 Code	Description	Notes
110-15	Engine Coolant Temperature : High - least severe (1)	The Electronic Control Module (ECM) detects that the coolant temperature is greater than 110° C (230° F) for at least 0.5 seconds. The code will be reset if the coolant temperature is less than 110° C (230° F) for at least 0.5 seconds. If equipped, the warning lamp will come on. The ECM will log the diagnostic code.
110-16	Engine Coolant Temperature : High - moderate severity (2)	The Electronic Control Module (ECM) detects that the coolant temperature is greater than 112° C (233.6° F) for at least 0.5 seconds. The code will be reset if the coolant temperature is less than 110° C (230° F) for at least 0.5 seconds. If equipped, the warning lamp will flash. The ECM will log the diagnostic code.

Probable Causes

- Diagnostic codes
- Coolant level

- Coolant temperature sensor
- Radiator and hoses
- Radiator cap and pressure relief valve
- Thermostat - Water temperature regulator
- Engine cooling fan
- Quality of coolant
- Coolant pump
- Cylinder head gasket

Recommended Actions

Note: The procedures have been listed in order of probability. Complete the procedures in order.

Table 2

Troubleshooting Test Steps	Values	Results
<p>1. Diagnostic Codes</p> <p>A. Use the electronic service tool to check for diagnostic codes that relate to the temperature in the cooling system.</p>	Diagnostic Codes	<p>Result: Diagnostic codes are not present.</p> <p>Return the unit to service.</p> <p>Result: Diagnostic codes are present.</p> <p>Proceed to Test Step 2.</p>
<p>2. Coolant Level</p> <p>A. Check the coolant level.</p>	Engine coolant level	<p>Result: The engine coolant level is low.</p> <p>Repair: Check the cooling system for leaks. Refer to Systems Operation, Testing and Adjusting, "Cooling System - Test" for additional information. Repair any leaks immediately.</p> <p>Result: The engine coolant level is OK.</p> <p>Proceed to Test Step 3.</p>
<p>3. Coolant Temperature Sensor</p>	Coolant	<p>Result: The temperature sensor is</p>

<p>A. Compare the reading for the coolant temperature on the electronic service tool to the reading for the coolant temperature on a calibrated test gauge.</p>	<p>temperature sensor</p>	<p>not accurate.</p> <p>Repair: Troubleshoot the circuit and the coolant temperature sensor. Refer to Troubleshooting, "Sensor Signal (Analog, Passive) - Test".</p> <p>Result: The temperature sensor is reading accurately.</p> <p>Proceed to Test Step 4.</p>
<p>4. Radiator and Hoses</p> <p>A. Check the radiator fins for dirt, debris, and/or damage.</p> <p>B. Check for collapsed hoses and/or other restrictions.</p> <p>C. Check the radiator for internal blockage.</p> <p>D. Ensure that the radiator size is sufficient. An undersized radiator does not have enough area for the effective release of heat. An undersized radiator may cause the engine to run at a temperature that is higher than normal. The normal temperature is dependent on the ambient temperature.</p>	<p>Radiator and hoses</p>	<p>Result: The radiator fins are blocked or damaged.</p> <p>Repair: Remove any dirt and/or debris and straighten any bent fins.</p> <p>Result: The radiator has internal blockage.</p> <p>Repair: Remove the blockage.</p> <p>Result: The radiator fins are not damaged and the radiator does not have an internal blockage.</p> <p>Proceed to Test Step 5.</p>
<p>5. Radiator Cap and Pressure Relief Valve</p> <p>A. Pressure-test the cooling system. Refer to Systems Operation, Testing, and Adjusting, "Cooling System" for the correct procedure.</p> <p>B. Check that the seating surfaces of the pressure relief valve and the radiator cap are clean and undamaged.</p> <p>C. Check operation of the pressure relief valve and/or the water temperature regulator.</p>	<p>Radiator cap</p>	<p>Result: The pressure relief valve and/or the water temperature regulator are not operating properly.</p> <p>Repair: Clean the components or replace the components.</p> <p>Result: The pressure relief valve and/or the water temperature regulator are operating properly.</p> <p>Proceed to Test Step 6.</p>

<p>6. Water Temperature Regulator</p> <p>A. Check the water temperature regulator for correct operation. Refer to Systems Operation, Testing, and Adjusting, "Cooling System" for the proper procedure.</p>	<p>Water Temperature Regulator</p>	<p>Result: The water temperature regulator is not operating correctly.</p> <p>Repair: Replace the water temperature regulator. Refer to Disassembly and Assembly, "Water Temperature Regulator - Remove and Install".</p> <p>Result: The water temperature regulator is operating correctly.</p> <p>Proceed to Test Step 7.</p>
<p>7. Engine Cooling Fan</p> <p>A. Check for a loose drive belt.</p> <p>Note: A loose fan drive belt will cause a reduction in the air flow across the radiator.</p> <p>B. Check the engine cooling fan for damage.</p>	<p>Fan and drive belt</p>	<p>Result: The drive belt is not tensioned correctly.</p> <p>Repair: Tension the fan belt. Refer to Operation and Maintenance Manual, "Alternator and Fan Belts - Replace".</p> <p>Result: The fan is damaged.</p> <p>Repair: Repair the fan or replace the fan, as necessary. Refer to Disassembly and Assembly, "Fan - Remove and Install".</p> <p>Result: The fan is OK and the fan belt is tensioned correctly.</p> <p>Proceed to Test Step 8.</p>
<p>8. Quality of Coolant</p> <p>A. Check the quality of the coolant. Refer to the Operation and Maintenance Manual, "Refill Capacities and Recommendations - Coolant".</p>	<p>Coolant</p>	<p>Result: The coolant is not of an acceptable quality.</p> <p>Repair: Drain and refill the coolant system with coolant of the correct quality. Refer to the Operation and Maintenance Manual, "Refill Capacities and Recommendations - Coolant".</p> <p>Result: The coolant is of an acceptable quality.</p>

		Proceed to Test Step 9.
<p>9. Inspection of the Coolant Pump</p> <p>A. Inspect the impeller of the coolant pump for damage and/or erosion.</p>	Coolant pump	<p>Result The coolant pump is damaged or not operating correctly.</p> <p>Repair: If necessary, replace the coolant pump. Refer to Disassembly and Assembly, "Water Pump - Remove" and Disassembly and Assembly, "Water Pump - Install".</p> <p>Result The coolant pump is not damaged and the pump is operating correctly.</p> <p>Proceed to Test Step 10.</p>
<p>10. Cylinder Head Gasket</p> <p>A. Switch off the engine and allow the engine to cool to below normal working temperature. Remove the pressure cap for the coolant system. Start the engine and inspect the coolant for the presence of bubbles or discoloration of the coolant.</p> <p>Note: If bubbles are present in the coolant or the coolant is discolored, combustion gases may be entering the cooling system.</p>	Cylinder Head gasket	<p>Result: Bubbles are present in the coolant or the coolant is discolored.</p> <p>Repair: Check the cylinder head gasket. Refer to the recommended action for the cylinder head gasket within Troubleshooting, "Oil Contains Coolant".</p> <p>Check the cylinder head for flatness. Refer to the recommended action for checking flatness of the cylinder head within Systems Operation, Testing, and Adjusting, "Cylinder Head - Inspect".</p> <p>Result: There is no evidence of gas leakage into the cooling system.</p>



Previous Screen



Troubleshooting C3.4B Engines

Media Number -UENR0611-10

Publication Date -01/02/2015

i06221244

Crankcase Breather Ejects Oil

SMCS - 1000-035-BBY; 1317-035

The crankcase breather includes a pressure relief valve that prevents a build-up of excessive pressure in the breather system.

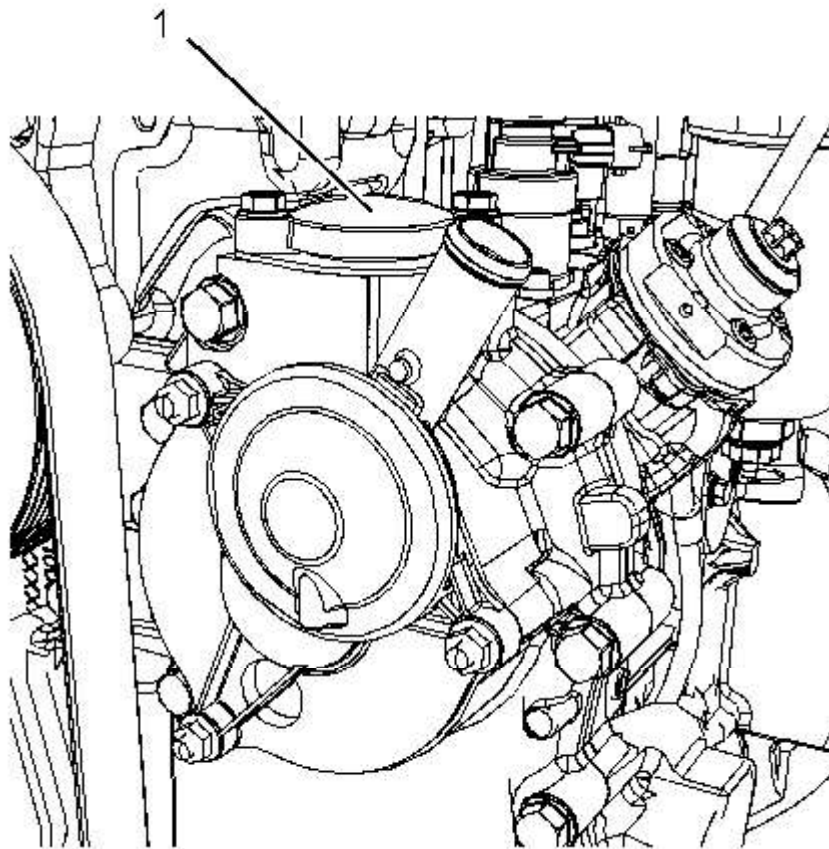

Illustration 1

g02919637

(1) Crankcase pressure relief valve

In normal operation of the engine, the pressure relief valve remains closed. If there is evidence of oil staining around pressure relief valve (1), perform the following procedure in order to diagnose the fault.

Probable Causes

- Breather filter
- Breather hoses
- Breather heater
- Excessive blow-by

Recommended Actions

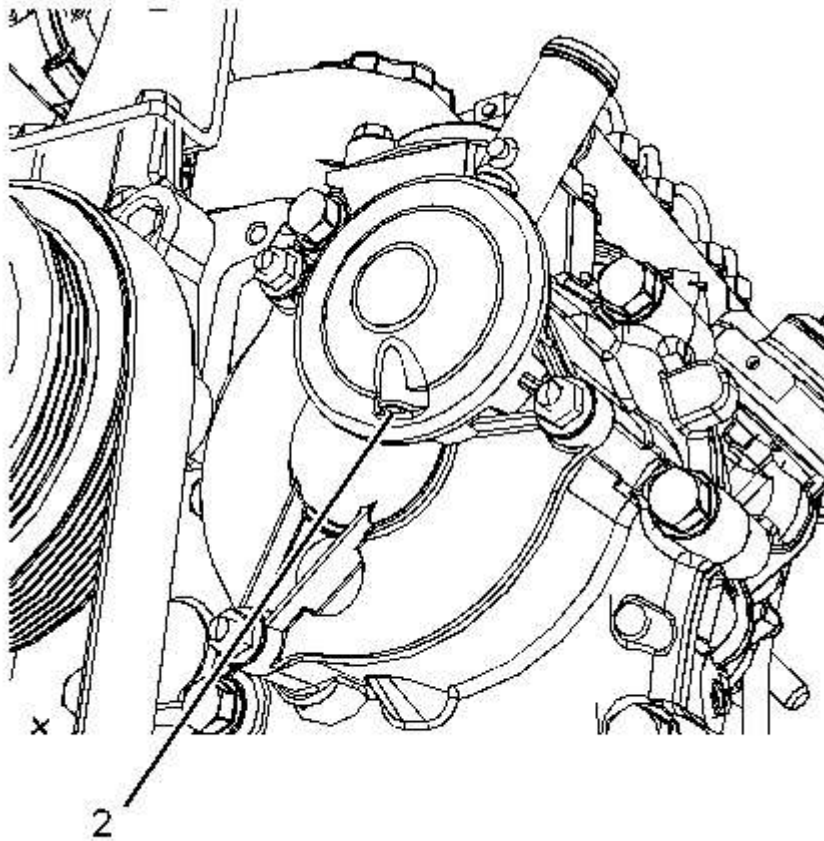

Illustration 2

g02919737

Table 1

Troubleshooting Test Steps	Values	Results
1. Breather Filter	Breather filter	Result: The breather element is incorrectly installed or damaged.

<p>A. Check that the breather element is correctly installed and that the element is not damaged.</p> <p>B. Check for restrictions or blockages in orifice (2).</p>		<p>Repair: Install a new filter element. Refer to Operation and Maintenance Manual, "Engine Crankcase Breather Element - Replace".</p> <p>Note: If a new filter element blocks before the service period is completed, the blockage can indicate a fault in the engine.</p> <p>Result: There is a restriction or blockage in orifice (2).</p> <p>Repair: If necessary, replace the crankcase breather. Refer to Disassembly and Assembly, "Crankcase Breather - Remove" and refer to Disassembly and Assembly, "Crankcase Breather - Install"</p> <p>Result: The breather filter is OK.</p> <p>Proceed to Test Step 2.</p>
<p>2. Breather Hoses</p> <p>A. Check the oil return hose and the breather outlet hose for restrictions or blockages.</p>	<p>Breather hoses</p>	<p>Result: There is a restriction or blockage in one of the breather hoses.</p> <p>Repair: Replace the breather hoses, as necessary.</p> <p>Result: The breather hoses are OK.</p> <p>Proceed to Test Step 3.</p>
<p>3. Breather Heater</p> <p>A. Turn the keyswitch to the OFF position.</p> <p>B. Disconnect the breather heater connector.</p> <p>C. Turn the keyswitch to the ON position.</p> <p>D. Use a suitable multimeter to measure the voltage at the harness connector for the heater.</p>	<p>10 V to 14 V for step D</p> <p>Less than 10 k Ohms for step F.</p>	<p>Result: The measured voltage is less than 10 V.</p> <p>There is a fault in the wiring to the breather heater.</p> <p>Repair: Repair the harness or repair the harness</p> <p>Result: The measured resistance is greater than 10 k Ohms.</p> <p>Repair: Replace the breather heater.</p> <p>Result: All measurements are within the expected ranges.</p>

<p>E. Turn the keyswitch to the OFF position.</p> <p>F. Use a suitable multimeter to measure the resistance of the heater element.</p>		<p>Proceed to Test Step 4.</p>
<p>4. Excessive Blow-by</p> <p>Excessive blow-by increases the flow of fumes through the breather system and can cause the breather element to block. The pressure relief valve may then open.</p> <p>A. If excessive blow-by is suspected, replace the breather element. Refer to the Operation and Maintenance Manual, "Engine Crankcase Breather Element - Replace".</p> <p>B. Investigate the cause of the excessive blow-by. Refer to Troubleshooting, "Oil Consumption Is Excessive".</p>	<p>Blow-by</p>	<p>Result: The fault has been rectified.</p> <p>Return the engine to service.</p>

CAT C3.4B Engine Parts
 Contact phone: 269 673 1638
 Email: EngineParts@HeavyEquipmentRestorationParts.com
 Alternate email: engineparts2@gmail.com
 Website: www.CATC34B.com
 Related website: www.HeavyEquipmentRestorationParts.com
www.FPTIndustrialEngineParts.com



Previous Screen



Troubleshooting
C3.4B Engines

Media Number -UENR0611-10

Publication Date -01/02/2015

i06221272

Cylinder Is Noisy

SMCS - 1223-035

Probable Causes

- Diagnostic codes
- Fuel quality
- Valve train components
- Injectors
- Pistons

Recommended Actions

Note: The procedures have been listed in order of probability. Complete the procedures in order.

Table 1

Troubleshooting Test Steps	Values	Results
<p>1. Diagnostic Codes</p> <p>A. Establish communication between the electronic service tool and the Electronic Control Module (ECM).</p> <p>B. Check for active diagnostic codes.</p>	<p>Codes</p>	<p>Result: A diagnostic trouble code is active or logged.</p> <p>Repair: Troubleshoot the active or logged codes. Refer to Troubleshooting, "Diagnostic Trouble Codes".</p> <p>Result: A diagnostic trouble code is not active or logged.</p> <p>Proceed to Test Step 2.</p>

<p>2. Fuel Quality</p> <p>A. Check the fuel quality. Refer to Systems Operation, Testing, and Adjusting, "Fuel Quality - Test".</p> <p>B. Refer to Operation and Maintenance Manual for information on the proper characteristics of the fuel for the engine.</p>	<p>Fuel</p>	<p>Result: The fuel quality is not OK.</p> <p>Repair: Drain the fuel system and replace the fuel filters. Refer to the Operation and Maintenance Manual, "Fuel System Primary Filter (Water Separator) Element - Replace" and Operation and Maintenance Manual, "Fuel System Filter - Replace".</p> <p>Fill the fuel system with fuel that meets the standard in the Operation and Maintenance Manual, "Fluid Recommendations".</p> <p>Prime the fuel system. Refer to the Operation and Maintenance Manual, "Fuel System - Prime".</p> <p>Verify that the procedure has eliminated the noise.</p> <p>Result: The fuel quality is OK.</p> <p>Proceed to Test Step 3.</p>
<p>3. Valve Train Components</p> <p>A. Check the valve lash. Refer to Troubleshooting, "Valve Lash Is Excessive".</p> <p>B. Check for damage to valve train components. Remove the valve cover from the suspect cylinders. Check the following items for damage:</p> <ul style="list-style-type: none"> · Valve springs · Rocker shaft · Pushrods · Camshaft followers <p>Refer to the Disassembly and Assembly for additional information.</p>	<p>Valve train</p>	<p>Result: Valve train components are damaged.</p> <p>Repair: Make the necessary repairs, Verify that the repair has eliminated the noise.</p> <p>Result: The valve train components are not damaged.</p> <p>Proceed to Test Step 4.</p>

<p>4. Electronic Unit Injectors</p> <p>A. Use the electronic service tool to check for active diagnostic codes that relate to the electronic unit injectors. Troubleshoot any active diagnostic codes before continuing with this procedure.</p>	<p>Diagnostic codes</p>	<p>Result: There is an active diagnostic code for the injectors.</p> <p>Repair: Troubleshoot any active injector diagnostic codes. Refer to Troubleshooting, "Diagnostic Trouble Codes".</p> <p>Result: There are no active diagnostic codes for the injectors.</p> <p>Proceed to Test Step 5.</p>
<p>5. Pistons</p> <p>A. Inspect the pistons for damage and wear.</p>	<p>Pistons</p>	<p>Result: One or more pistons are worn or damaged.</p> <p>Repair : Replace any worn or damaged parts.</p> <p>Verify that the repair has eliminated the noise.</p> <p>Result: All pistons are OK.</p> <p>Contact the Dealer Solution Network (DSN).</p>

CAT C3.4B Engine Parts
Contact phone: 269 673 1638
Email: EngineParts@HeavyEquipmentRestorationParts.com
Alternate email: engineparts2@gmail.com
Website: www.CATC34B.com
Related website: www.HeavyEquipmentRestorationParts.com
www.FPTIndustrialEngineParts.com



Previous Screen



Troubleshooting

C3.4B Engines

Media Number -UENR061.1-10

Publication Date -01/02/2015

i06008869

Data Link - Test

SMCS - 1900-038

Use this procedure if a fault is suspected in the CAN data link. This procedure also covers the following diagnostic codes:

Table 1

Diagnostic Trouble Codes for the CAN Data Link		
J1939 Code	Description	Notes
639-9	J1939 Network #1 : Abnormal Update Rate	Another controller has incorrectly stopped transmitting a J1939 speed request (TSC1) or another controller has incorrectly started transmitting a J1939 speed request. The ECM will log the diagnostic code. The engine will not start.
639-14	J1939 Network #1 : Special Instruction	Another controller has incorrectly stopped transmitting a signal on the CAN data link.

The following background information is related to this procedure:

The CAN data link is also known as J1939 data link. The data link is an industry standard for sending data between different devices in the same application.

High speed data is transferred via the data link. The data link cannot be accurately tested without complicated equipment. The data link requires a resistance of 60 Ohms between the two wires in order to transmit the data correctly. This resistance is made up of two 120 Ohm resistors. The two resistors are known as "Terminating Resistors". The terminating resistors should be at opposite ends of a data link circuit. If this resistance is not present, then the data will be intermittent or unreadable.

Note: The wiring for the J1939 data link is a shielded twisted pair cable. If the wiring is damaged, the replacement type must be shielded twisted pair cable.

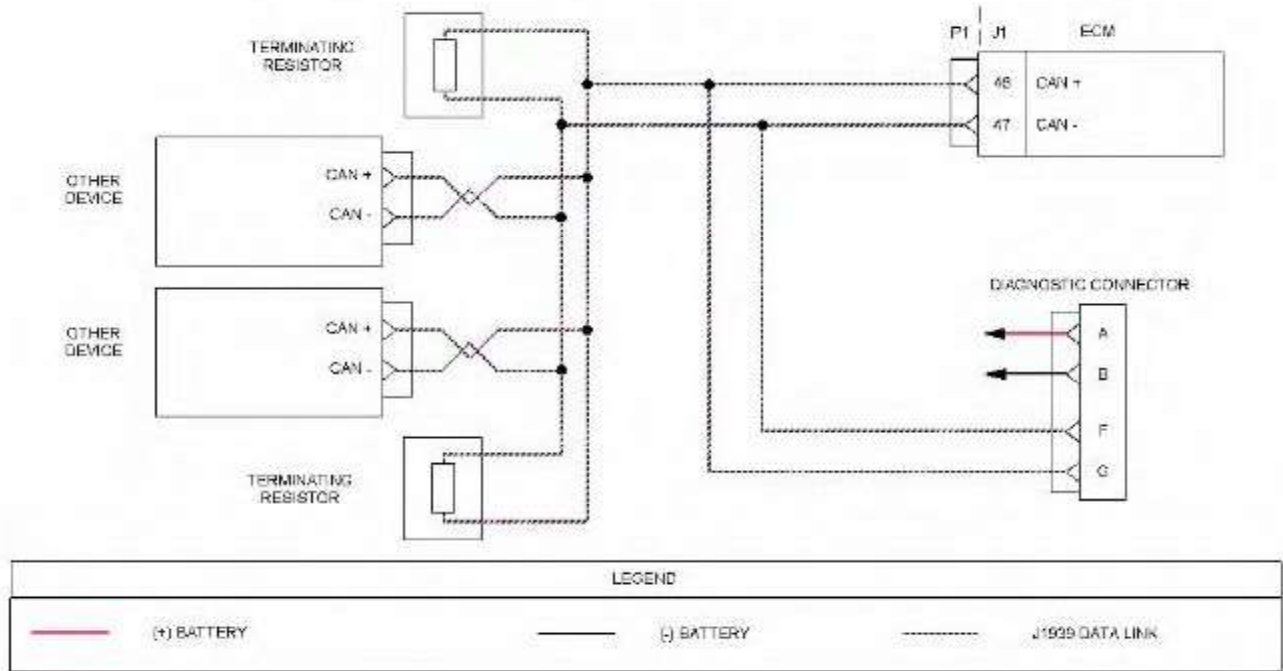

Illustration 1

g03600780

Typical example of the schematic for the CAN data link

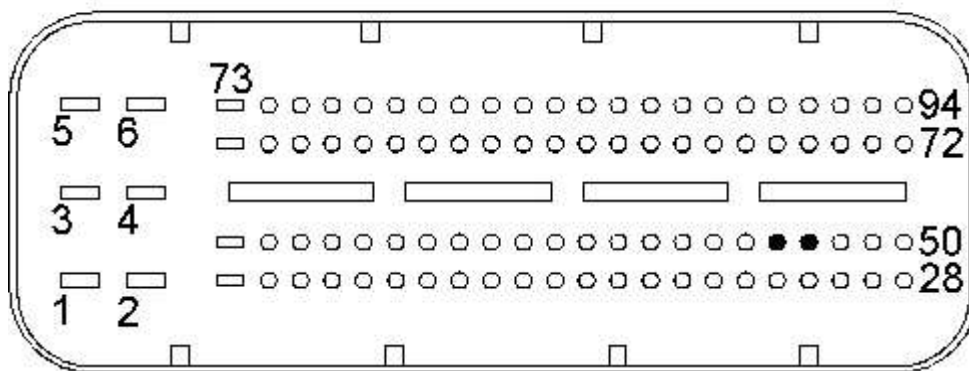

Illustration 2

g03600802

Typical view of the pin locations on the P1 connector

(46) CAN +

(47) CAN -

Table 2

Troubleshooting Test Steps	Values	Results
<p>1. Inspect Electrical Connectors and Wiring</p> <p>A. Turn the keyswitch to the OFF position.</p> <p>B. Inspect the connectors in the circuit for the CAN data link. Refer to Troubleshooting, "Electrical Connectors - Inspect" for details.</p> <p>C. Perform a 30 N (6.7 lb) pull test on each of the wires that are associated with the CAN data link.</p> <p>D. Check all of the wiring associated with the CAN data link for abrasions and pinch points.</p>	<p>Damaged wire or connector</p>	<p>Result: A damaged wire or damaged connector was found.</p> <p>Repair the damaged wire or the damaged connector.</p> <p>Use the electronic service tool to clear all logged diagnostic codes. Verify that the repair eliminates the fault.</p> <p>Result: A damaged wire or damaged connector was not found.</p> <p>Proceed to Test Step 2.</p>
<p>2. Check the Data Link Terminating Resistance</p> <p>A. Disconnect the P1 connector from the ECM.</p> <p>B. Measure the resistance between the P1:46 and P1:47.</p>	<p>Between 50 Ohms and 70 Ohms</p>	<p>Result: The resistance is less than 50 Ohms - there is a short circuit in the harness.</p> <p>Repair the connectors or the harness and/or replace the connectors or the harness. Ensure that all of the seals are correctly in place and ensure that the connectors are correctly connected.</p> <p>Use the electronic service tool in order to clear all logged diagnostic codes and then verify that the repair eliminates the fault.</p> <p>Result: The resistance is between 110 and 130 Ohms - one of the terminating resistors may have failed.</p> <p>Locate the two terminating resistors and remove the two terminating resistors from the harness. The terminating resistors may be located in other ECMs on the data link. Refer to the Electrical Schematic.</p> <p>Measure the resistance of the two terminating</p>

		<p>resistors. If one of the terminating resistors is incorrect, replace the faulty terminating resistor. If the two terminating resistors are between 50 and 70 Ohms each, proceed to Test Step 4.</p> <p>Result: The resistance is greater than 150 Ohms.</p> <p>Proceed to Test Step 3.</p> <p>Result: The resistance is between 50 and 70 Ohms</p> <p>This is the correct resistance. The fault may be in the connection to other devices on the data link. Proceed to Test Step 3.</p>
<p>3. Check the Data Link Wiring</p> <p>A. Disconnect each of the connectors that connect other devices on the data link.</p> <p>B. Use a multimeter to measure the resistance between P1:46 and each of the CAN+ pins for other devices on the CAN data link.</p> <p>C. Use a multimeter to measure the resistance between P1:46 and pin F on the diagnostic connector.</p> <p>D. Use a multimeter to measure the resistance between P1:47 and each of the CAN- pins for other devices on the CAN data link.</p> <p>E. Use a multimeter in order to measure the resistance between P1:47 and pin G on the diagnostic connector.</p>	<p>Less than 5 Ohms</p>	<p>Result: At least one of the resistance measurements is greater than 5 Ohms - there is an open circuit or high resistance in the wiring.</p> <p>Repair the connectors or the harness and/or replace the connectors or the harness. Ensure that all seals are correctly in place and ensure that the connectors are correctly connected.</p> <p>Use the electronic service tool in order to clear all logged diagnostic codes and then verify that the repair has eliminated the fault.</p> <p>Result: All measured resistances are less than 2 Ohms.</p> <p>Proceed to Test Step 4</p>
<p>4. Check the Other Devices on the CAN Data Link</p> <p>A. Use the appropriate service tools in</p>	<p>Other devices are OK</p>	<p>Result: At least one of the other devices is not operating correctly.</p> <p>Use the appropriate service tools in order to</p>

order to diagnose other devices on the data link.

repair other devices on the data link.

Use the electronic service tool in order to clear all logged diagnostic codes and then verify that the repair eliminates the fault.

Result: The other devices are operating correctly.

Contact the Dealer Solution Network (DSN).



Troubleshooting

C3.4B Engines

Media Number -UENR0611-10

Publication Date -01/02/2015

i05981906

Diagnostic Capabilities

SMCS - 1900

Diagnostic Codes

The Electronic Control Module (ECM) can monitor the circuitry between the ECM and the engines components. The ECM can also monitor the engines operating conditions. If the ECM detects a problem, a diagnostic code is generated.

Codes can have two different states:

- Active
- Logged

Active Codes

An active code indicates that a problem is present. Service the active code first. For the appropriate troubleshooting procedure for a particular code, refer to the following troubleshooting procedure:

- Troubleshooting, "Diagnostic Trouble Codes"

Logged Codes

The codes are logged and stored in the ECM memory. The problem may have been repaired and/or the problem may no longer exist. If the system is powered, an active diagnostic code may be generated whenever a component is disconnected. If the component is reconnected, the code is no longer active but the code may become logged.

Logged diagnostic codes will be cleared from the "Logged Diagnostic Codes" screen on the electronic service tool when the code has not been active for 40 hours.

Logged codes may not indicate that a repair is needed. The problem may have been temporary. Logged codes may be useful to help troubleshoot intermittent problems. Logged codes can also be used to review the performance of the engine and of the electronic system.



Previous Screen



Troubleshooting
C3.4B Engines

Media Number -UENR0611-10

Publication Date -01/02/2015

i06867595

Diagnostic Trouble Codes

SMCS - 1900

The following table lists all the J1939 diagnostic trouble codes for the engine. The table includes a description for each code and the recommended troubleshooting procedure that must be performed.

Portions of this material are reprinted with permission from SAE J1939DA_201607[©] 2016 SAE International. SAE International is not responsible for any use or translation of this material, in whole or in part. Please contact SAE International to obtain a complete copy of SAE J1939DA_201607, the official definitive source of this standard.

Table 1

J1939 Code	Description	Refer to Procedure
27-3	Engine Exhaust Gas Recirculation Valve Position : Voltage Above Normal	Valve Position - Test
27-4	Engine Exhaust Gas Recirculation Valve Position : Voltage Below Normal	Valve Position - Test
29-3	Accelerator Pedal Position 2 : Voltage Above Normal	Speed Control - Test
29-4	Accelerator Pedal Position 2 : Voltage Below Normal	Speed Control - Test
51-3	Engine Throttle Valve 1 Position : Voltage Above Normal	Valve Position - Test
51-4	Engine Throttle Valve 1 Position : Voltage Below Normal	Valve Position - Test
91-3		Speed Control - Test

	Accelerator Pedal Position 1 : Voltage Above Normal	
91-4	Accelerator Pedal Position 1 : Voltage Below Normal	Speed Control - Test
97-15	Water in Fuel Indicator : High - least severe (1)	Fuel Contains Water
100-2	Engine Oil Pressure : Erratic, Intermittent, or Incorrect	Switch Circuits - Test (Oil Pressure Switch)
100-17	Engine Oil Pressure : Low - least severe (1)	Oil Pressure Is Low
102-3	Engine Intake Manifold #1 Pressure : Voltage Above Normal	Sensor Signal (Analog, Active) - Test
102-4	Engine Intake Manifold #1 Pressure : Voltage Below Normal	Sensor Signal (Analog, Active) - Test
102-20	Engine Intake Manifold #1 Pressure : Data Drifted High	Sensor Signal (Analog, Active) - Test
102-21	Engine Intake Manifold #1 Pressure : Data Drifted Low	Sensor Signal (Analog, Active) - Test
105-3	Engine Intake Manifold #1 Temperature : Voltage Above Normal	Sensor Signal (Analog, Passive) - Test
105-4	Engine Intake Manifold #1 Temperature : Voltage Below Normal	Sensor Signal (Analog, Passive) - Test
107-2	Engine Air Filter 1 Differential Pressure : Erratic, Intermittent, or Incorrect	Switch Circuits - Test (Air Filter Restriction Switch)
107-15	Engine Air Filter 1 Differential Pressure : High - least severe (1)	Inlet Air Is Restricted
107-16	Engine Air Filter 1 Differential Pressure : High - moderate severity (2)	Inlet Air Is Restricted
108-3	Barometric Pressure : Voltage Above Normal	Sensor Signal (Analog, Active) - Test
108-4	Barometric Pressure : Voltage Below Normal	Sensor Signal (Analog, Active) - Test
110-3	Engine Coolant Temperature : Voltage Above Normal	Sensor Signal (Analog, Passive) - Test
110-4	Engine Coolant Temperature : Voltage Below Normal	Sensor Signal (Analog, Passive) - Test

110-15	Engine Coolant Temperature : High - least severe (1)	Coolant Temperature Is High
110-16	Engine Coolant Temperature : High - moderate severity (2)	Coolant Temperature Is High
152-2	Number Of ECU Resets : Erratic, Intermittent, or Incorrect	ECM Memory - Test
157-0	Engine Injector Metering Rail #1 Pressure : High - most severe (3)	Fuel Rail Pressure Problem
157-2	Engine Injector Metering Rail #1 Pressure : Erratic, Intermittent, or Incorrect	Fuel Rail Pressure Problem
157-3	Engine Injector Metering Rail #1 Pressure : Voltage Above Normal	Sensor Signal (Analog, Active) - Test
157-4	Engine Injector Metering Rail #1 Pressure : Voltage Below Normal	Sensor Signal (Analog, Active) - Test
157-10	Engine Injector Metering Rail #1 Pressure : Abnormal Update Rate	Sensor Signal (Analog, Active) - Test
157-16	Engine Injector Metering Rail #1 Pressure : High - moderate severity (2)	Fuel Rail Pressure Problem
157-17	Engine Injector Metering Rail #1 Pressure : Low - least severe (1)	Fuel Rail Pressure Problem
157-18	Engine Injector Metering Rail #1 Pressure : Low - moderate severity (2)	Fuel Rail Pressure Problem
166-2	Engine Rated Power : Erratic, Intermittent, or Incorrect	ECM Memory - Test
166-14	Engine Rated Power : Special Instuction	ECM Memory - Test
168-3	Battery Potential / Power Input 1 : Voltage Above Normal	Electrical Power Supply - Test
168-4	Battery Potential / Power Input 1 : Voltage Above Normal	Electrical Power Supply - Test
172-3	Engine Air Inlet Temperature : Voltage Above Normal	Sensor Signal (Analog, Passive) - Test
172-4	Engine Air Inlet Temperature : Voltage Below Normal	Sensor Signal (Analog, Passive) - Test
173-3	Engine Exhaust Gas Temperature : Voltage Above Normal	Sensor Signal (Analog, Passive) - Test
173-4		Sensor Signal (Analog, Passive) - Test

	Engine Exhaust Gas Temperature : Voltage Below Normal	
174-3	Engine Fuel Temperature 1 : Voltage Above Normal	Sensor Signal (Analog, Passive) - Test
174-4	Engine Fuel Temperature 1 : Voltage Below Normal	Sensor Signal (Analog, Passive) - Test
190-8	Engine Speed : Abnormal Frequency, Pulse Width, or Period	Speed/Timing - Test
190-15	Engine Speed : High - least severe (1)	Engine Overspeeds
558-2	Accelerator Pedal 1 Low Idle Switch : Erratic, Intermittent, or Incorrect	Idle Validation - Test
593-31	Engine Idle Shutdown has Shutdown Engine	This code indicates that an engine idle shutdown is about to occur. This code does not represent a fault. If equipped, the warning lamp will come on.
594-31	Engine Idle Shutdown Driver Alert Mode	This code indicates that an engine idle shutdown has occurred. This code does not represent a fault. If equipped, the warning lamp will flash and the shutdown lamp will come on.
623-5	Red Stop Lamp : Current Below Normal	Indicator Lamp - Test
623-6	Red Stop Lamp : Current Above Normal	Indicator Lamp - Test
624-5	Amber Warning Lamp : Current Below Normal	Indicator Lamp - Test
624-6	Amber Warning Lamp : Current Above Normal	Indicator Lamp - Test
630-2	Calibration Memory : Erratic, Intermittent, or Incorrect	Injector Data Incorrect - Test
637-11	Engine Timing Sensor : Other Failure Mode	Speed/Timing - Test
639-9	J1939 Network #1 : Abnormal Update Rate	Data Link - Test
639-14	J1939 Network #1 : Special Instruction	Data Link - Test
651-5	Engine Injector Cylinder #01 : Current Below Normal	Injector Solenoid - Test

651-6	Engine Injector Cylinder #01 : Current Above Normal	Injector Solenoid - Test
651-20	Engine Injector Cylinder #01 : Data Drifted High	Injector Data Incorrect - Test
651-21	Engine Injector Cylinder #01 : Data Drifted Low	Injector Data Incorrect - Test
652-5	Engine Injector Cylinder #02 : Current Below Normal	Injector Solenoid - Test
652-6	Engine Injector Cylinder #02 : Current Above Normal	Injector Solenoid - Test
652-20	Engine Injector Cylinder #02 : Data Drifted High	Injector Data Incorrect - Test
652-21	Engine Injector Cylinder #02 : Data Drifted Low	Injector Data Incorrect - Test
653-5	Engine Injector Cylinder #03 : Current Below Normal	Injector Solenoid - Test
653-6	Engine Injector Cylinder #03 : Current Above Normal	Injector Solenoid - Test
653-20	Engine Injector Cylinder #03 : Data Drifted High	Injector Data Incorrect - Test
653-21	Engine Injector Cylinder #03 : Data Drifted Low	Injector Data Incorrect - Test
654-5	Engine Injector Cylinder #04 : Current Below Normal	Injector Solenoid - Test
654-6	Engine Injector Cylinder #04 : Current Above Normal	Injector Solenoid - Test
654-20	Engine Injector Cylinder #04 : Data Drifted High	Injector Data Incorrect - Test
654-21	Engine Injector Cylinder #04 : Data Drifted Low	Injector Data Incorrect - Test
676-5	Engine Glow Plug Relay : Current Below Normal	Glow Plug Starting Aid - Test
676-6	Engine Glow Plug Relay : Current Above Normal	Glow Plug Starting Aid - Test
676-19	Engine Glow Plug Relay : Data Error	Glow Plug Starting Aid - Test
677-3	Engine Starter Motor Relay : Voltage Above Normal	Relay - Test (Start Relay)
677-5		Relay - Test (Start Relay)

	Engine Starter Motor Relay : Current Below Normal	
677-6	Engine Starter Motor Relay : Current Above Normal	Relay - Test (Start Relay)
723-8	Engine Speed Sensor #2 : Abnormal Frequency, Pulse Width, or Period	Speed/Timing - Test
970-31	Engine Auxiliary Shutdown Switch	This code indicates that the shutdown switch for the engine has been activated. The ECM will disable fuel injection until the switch has been deactivated. No troubleshooting is required.
976-2	PTO Governor State : Erratic, Intermittent, or Incorrect	Power Take-Off - Test
1041-2	Start Signal Indicator : Erratic, Intermittent, or Incorrect	Relay - Test (Start Relay)
1076-2	Engine Fuel Injection Pump Fuel Control Valve : Erratic, Intermittent, or Incorrect	Solenoid Valve - Test
1076-5	Engine Fuel Injection Pump Fuel Control Valve : Current Below Normal	Solenoid Valve - Test
1076-6	Engine Fuel Injection Pump Fuel Control Valve : Current Above Normal	Solenoid Valve - Test
1081-5	Engine Wait to Start Lamp : Current Below Normal	Indicator Lamp - Test
1081-6	Engine Wait to Start Lamp : Current Above Normal	Indicator Lamp - Test
1110-31	Engine Protection System has Shutdown Engine	The engine protection system has shutdown the engine. Troubleshoot all other diagnostic codes in order to clear this code.
1127-16	Engine Turbocharger 1 Boost Pressure : High - moderate severity (2)	Intake Manifold Air Pressure Is High
1127-18	Engine Turbocharger 1 Boost Pressure : Low - moderate severity (2)	Intake Manifold Air Pressure Is Low
1188-5	Engine Turbocharger Wastegate Actuator 1 Position : Current Below Normal	Solenoid Valve - Test

1188-6	Engine Turbocharger Wastegate Actuator 1 Position : Current Above Normal	Solenoid Valve - Test
1209-3	Engine Exhaust Gas Pressure : Voltage Above Normal	Sensor Signal (Analog, Active) - Test (Exhaust Gas Pressure Sensor)
1209-4	Engine Exhaust Gas Pressure : Voltage Below Normal	Sensor Signal (Analog, Active) - Test (Exhaust Gas Pressure Sensor)
1221-2	Continuously Monitored Systems Support/Status ; Erratic, Intermittent, or Incorrect	ECM Memory - Test
1221-14	Continuously Monitored Systems Support/Status ; Special Instruction	Another diagnostic code has requested engine speed limitation. The warning lamp will flash. The engine speed is limited to 1200 rpm. Troubleshoot all other diagnostic codes. If this code is the only active diagnostic code, replace the ECM. Refer to Troubleshooting, "ECM - Replace"
1239-0	Engine Fuel Leakage 1 : High - most severe (3)	Fuel Rail Pressure Problem
1485-7	ECM Main Relay : Not Responding Properly	Relay - Test (ECM Main Relay)
1485-14	ECM Main relay : Special Instruction	Relay - Test (ECM Main Relay)
2791-5	Engine Exhaust Gas Recirculation (EGR) Valve Control : Current Below Normal	Motorized Valve - Test
2791-6	Engine Exhaust Gas Recirculation (EGR) Valve Control : Current Above Normal	Motorized Valve - Test
2791-7	Engine Exhaust Gas Recirculation (EGR) Valve Control : Not Responding Properly	Motorized Valve - Test
2797-6	Engine Injector Group 1 : Current Above Normal	Injector Solenoid - Test
2797-7	Engine Injector Group 1 : Not Responding Properly	Injector Solenoid - Test
2798-6	Engine Injector Group 2 : Current Above Normal	Injector Solenoid - Test
2840-12	ECU Instance : Failure	ECM Memory - Test
		Relay - Test (ECM Main Relay)

2840-14	ECU Instance : Special Instruction	
2880-2	Engine Operator Primary Intermediate Speed Select : Erratic, Intermittent, or Incorrect	Mode Selection - Test/Switch Circuits - Test (Throttle Switch)
2880-3	Engine Operator Primary Intermediate Speed Select : Voltage Above Normal	Mode Selection - Test/Switch Circuits - Test (Throttle Switch)
2880-4	Engine Operator Primary Intermediate Speed Select : Voltage Below Normal	Mode Selection - Test/Switch Circuits - Test (Throttle Switch)
2970-2	Accelerator Pedal 2 Low Idle Switch : Erratic, Intermittent, or Incorrect	Idle Validation - Test
3217-3	Aftertreatment #1 Intake O2 : Voltage Above Normal	Oxygen Level - Test
3217-4	Aftertreatment #1 Intake O2 : Voltage Below Normal	Oxygen Level - Test
3217-5	Aftertreatment #1 Intake O2 : Current Below Normal	Oxygen Level - Test
3217-6	Aftertreatment #1 Intake O2 : Current Above Normal	Oxygen Level - Test
3217-12	Aftertreatment #1 Intake O2 : Failure	Oxygen Level - Test
3217-13	Aftertreatment #1 Intake O2 : Out of Calibration	Oxygen Level - Test
3217-15	Aftertreatment #1 Intake O2 : High - least severe (1)	Oxygen Level - Test
3219-15	Aftertreatment #1 Intake Gas Sensor at Temperature : High - least severe (1)	Oxygen Level - Test
3219-17	Aftertreatment #1 Intake Gas Sensor at Temperature : Low - least severe (1)	Oxygen Level - Test
3222-3	Aftertreatment #1 Intake Gas Sensor Heater : Voltage Above Normal	Oxygen Level - Test
3222-4	Aftertreatment #1 Intake Gas Sensor Heater : Voltage Below Normal	Oxygen Level - Test
3222-5		Oxygen Level - Test

	Aftertreatment #1 Intake Gas Sensor Heater : Current Below Normal	
3242-0	Particulate Trap Intake Gas Temperature : High - most severe (3)	Sensor Signal (Analog, Passive) - Test
3242-3	Particulate Trap Intake Gas Temperature : Voltage Above Normal	Sensor Signal (Analog, Passive) - Test
3242-4	Particulate Trap Intake Gas Temperature : Voltage Below Normal	Sensor Signal (Analog, Passive) - Test
3251-0	Particulate Trap Differential Pressure : High - most severe (3)	Diesel Particulate Filter Collects Excessive Soot
3251-3	Particulate Trap Differential Pressure : Voltage Above Normal	Sensor Signal (Analog, Active) - Test
3251-4	Particulate Trap Differential Pressure : Voltage Below Normal	Sensor Signal (Analog, Active) - Test
3251-7	Particulate Trap Differential Pressure : Not Responding Properly	Diesel Particulate Filter Has Differential Pressure Problem
3251-10	Particulate Trap Differential Pressure : Abnormal Rate of Change	Diesel Particulate Filter Has Differential Pressure Problem
3251-16	Particulate Trap Differential Pressure : High - moderate severity (2)	Diesel Particulate Filter Collects Excessive Soot
3251-17	Particulate Trap Differential Pressure : Low - least severe (1)	Diesel Particulate Filter Has Differential Pressure Problem
3251-18	Particulate Trap Differential Pressure : Low - moderate severity (2)	Diesel Particulate Filter Has Differential Pressure Problem
3358-10	Engine Exhaust Gas Recirculation 1 Intake Pressure : Abnormal Rate of Change	NRS Mass Flow Rate Problem
3509-2	Sensor Supply Voltage 1 : Erratic, Intermittent, or Incorrect	Sensor Supply - Test
3510-2	Sensor Supply Voltage 2 : Erratic, Intermittent, or Incorrect	Sensor Supply - Test
3511-2	Sensor Supply Voltage 3 : Erratic, Intermittent, or Incorrect	Sensor Supply - Test

3697-5	Particulate Trap Lamp Command : Current Below Normal	Indicator Lamp - Test
3697-6	Particulate Trap Lamp Command : Current Above Normal	Indicator Lamp - Test
3698-5	Exhaust System High Temperature Lamp Command : Current Below Normal	Indicator Lamp - Test
3698-6	Exhaust System High Temperature Lamp Command : Current Above Normal	Indicator Lamp - Test
3702-5	Diesel Particulate Filter Active Regeneration Inhibited Status : Current Below Normal	Indicator Lamp - Test
3702-6	Diesel Particulate Filter Active Regeneration Inhibited Status : Current Above Normal	Indicator Lamp - Test
3719-0	Aftertreatment 1 Diesel Particulate Filter Soot Load Percent : High - most severe (3)	Diesel Particulate Filter Collects Excessive Soot
3719- 16	Aftertreatment 1 Diesel Particulate Filter Soot Load Percent : High - moderate severity (2)	Diesel Particulate Filter Collects Excessive Soot
4765-3	Aftertreatment #1 Diesel Oxidation Catalyst Intake Gas Temperature : Voltage Above Normal	Sensor Signal (Analog, Passive) - Test
4765-4	Aftertreatment #1 Diesel Oxidation Catalyst Intake Gas Temperature : Voltage Below Normal	Sensor Signal (Analog, Passive) - Test
5055- 17	Engine Oil Viscosity : Low - least severe (1)	Oil Contains Fuel
5055- 18	Engine Oil Viscosity : Low - moderate severity (2)	Oil Contains Fuel
5099-5	Engine Oil Pressure Low Lamp Data - Current Below Normal	Indicator Lamp - Test
5099-6	Engine Oil Pressure Low Lamp Data - Current Above Normal	Indicator Lamp - Test
5246- 15	Aftertreatment SCR Operator Inducement Severity : High - least severe (1)	See "Operator Inducement Codes".
		See "Operator Inducement Codes".

5246-16	Aftertreatment SCR Operator Inducement Severity : High - moderate severity (2)	
5319-31	Aftertreatment 1 Diesel Particulate Filter Incomplete Regeneration	Diesel Particulate Filter Active Regeneration Was Interrupted
5324-7	Engine Glow Plug 1 : Not Responding Properly	Glow Plug Starting Aid - Test
5325-7	Engine Glow Plug 2 : Not Responding Properly	Glow Plug Starting Aid - Test
5326-7	Engine Glow Plug 3 : Not Responding Properly	Glow Plug Starting Aid - Test
5327-7	Engine Glow Plug 4 : Not Responding Properly	Glow Plug Starting Aid - Test
5357-31	Engine Fuel Injection Quantity Error for Multiple Cylinders	ECM Memory - Test
5419-5	Engine Throttle Actuator #1 : Current Below Normal	Motorized Valve - Test
5419-6	Engine Throttle Actuator #1 : Current Above Normal	Motorized Valve - Test
5419-7	Engine Throttle Actuator #1 : Not Responding Properly	Motorized Valve - Test
5571-2	High Pressure Common Rail Fuel Pressure Relief Valve : Erratic, Intermittent, or Incorrect	Fuel Rail Pressure Problem
5571-7	High Pressure Common Rail Fuel Pressure Relief Valve : Not Responding Properly	Fuel Rail Pressure Problem
5571-10	High Pressure Common Rail Fuel Pressure Relief Valve : Abnormal Rate of Change	Fuel Rail Pressure Problem
5571-14	High Pressure Common Rail Fuel Pressure Relief Valve : Special Instruction	Fuel Rail Pressure Problem
5571-16	High Pressure Common Rail Fuel Pressure Relief Valve : High - moderate severity (2)	Fuel Rail Pressure Problem
5826-15	Emission Control System Operator Inducement Severity : High - least severe (1)	See "Operator Inducement Codes".
5826-16		See "Operator Inducement Codes".

Emission Control System Operator Inducement Severity : High - moderate severity (2)

Operator Inducement Codes

If any of the diagnostic codes listed in Table 2 are active, a 5246 or a 5826 diagnostic code will also be active.

When a 5246 or a 5826 diagnostic code is active, the engine will be derated.

In order to clear an active 5246 or a 5826 diagnostic code, first troubleshoot any active codes that are listed in Table 2. Once all other codes are cleared, cycle the keyswitch in order to clear the 5246 or 5826 diagnostic code.

Table 2

J1939 Code	Description	Refer to Procedure
27-3	Engine Exhaust Gas Recirculation Valve Position : Voltage Above Normal	Valve Position Sensor - Test
27-4	Engine Exhaust Gas Recirculation Valve Position : Voltage Below Normal	Valve Position Sensor - Test
102-3	Engine Intake Manifold #1 Pressure : Voltage Above Normal	Engine Pressure Sensor Open or Short Circuit - Test
102-4	Engine Intake Manifold #1 Pressure : Voltage Below Normal	Engine Pressure Sensor Open or Short Circuit - Test
102-20	Engine Intake Manifold #1 Pressure : Data Drifted High	Engine Pressure Sensor Open or Short Circuit - Test
102-21	Engine Intake Manifold #1 Pressure : Data Drifted Low	Engine Pressure Sensor Open or Short Circuit - Test
105-3	Engine Intake Manifold #1 Temperature : Voltage Above Normal	Engine Temperature Sensor Open or Short Circuit - Test
105-4	Engine Intake Manifold #1 Temperature : Voltage Below Normal	Engine Temperature Sensor Open or Short Circuit - Test
108-3	Barometric Pressure : Voltage Above Normal	Engine Pressure Sensor Open or Short Circuit - Test
108-4	Barometric Pressure : Voltage Below Normal	Engine Pressure Sensor Open or Short Circuit - Test
157-0	Engine Injector Metering Rail #1 Pressure : High - most severe (3)	Fuel Rail Pressure Problem
157-2	Engine Injector Metering Rail #1 Pressure : Erratic, Intermittent, or Incorrect	Fuel Rail Pressure Problem

157-16	Engine Injector Metering Rail #1 Pressure : High - moderate severity (2)	Fuel Rail Pressure Problem
157-18	Engine Injector Metering Rail #1 Pressure : Low - moderate severity (2)	Fuel Rail Pressure Problem
173-3	Engine Exhaust Gas Temperature : Voltage Above Normal	Engine Temperature Sensor Open or Short Circuit - Test
173-4	Engine Exhaust Gas Temperature : Voltage Below Normal	Engine Temperature Sensor Open or Short Circuit - Test
1076-5	Engine Fuel Injection Pump Fuel Control Valve : Current Below Normal	Solenoid Valve - Test
1076-6	Engine Fuel Injection Pump Fuel Control Valve : Current Above Normal	Solenoid Valve - Test
1188-5	Engine Turbocharger Wastegate Actuator 1 Position : Current Below Normal	Solenoid Valve - Test
1209-3	Engine Exhaust Gas Pressure : Voltage Above Normal	Engine Pressure Sensor Open or Short Circuit - Test
1209-4	Engine Exhaust Gas Pressure : Voltage Below Normal	Engine Pressure Sensor Open or Short Circuit - Test
1239-0	Engine Fuel Leakage 1 : High - most severe (3)	Fuel Rail Pressure Problem
2791-5	Engine Exhaust Gas Recirculation (EGR) Valve Control : Current Below Normal	Motorized Valve - Test
2791-6	Engine Exhaust Gas Recirculation (EGR) Valve Control : Current Above Normal	Motorized Valve - Test
2791-7	Engine Exhaust Gas Recirculation (EGR) Valve Control : Not Responding Properly	Motorized Valve - Test
3251-3	Particulate Trap Differential Pressure : Voltage Above Normal	Engine Pressure Sensor Open or Short Circuit - Test
3251-4	Particulate Trap Differential Pressure : Voltage Below Normal	Engine Pressure Sensor Open or Short Circuit - Test
3251-7	Particulate Trap Differential Pressure : Not Responding Properly	Diesel Particulate Filter Has Differential Pressure Problem
3251-10	Particulate Trap Differential Pressure : Abnormal Rate of Change	Diesel Particulate Filter Has Differential Pressure Problem
3251-18	Particulate Trap Differential Pressure : Low - moderate severity (2)	Diesel Particulate Filter Has Differential Pressure Problem
3358-10	Engine Exhaust Gas Recirculation 1 Intake Pressure : Abnormal Rate of Change	NRS Mass Flow Rate Problem
3509-2	Sensor Supply Voltage 1 : Erratic, Intermittent, or Incorrect	Sensor Supply - Test

3510-2	Sensor Supply Voltage 2 : Erratic, Intermittent, or Incorrect	Sensor Supply - Test
3511-2	Sensor Supply Voltage 3 : Erratic, Intermittent, or Incorrect	Sensor Supply - Test
4765-3	Aftertreatment #1 Diesel Oxidation Catalyst Intake Gas Temperature : Voltage Above Normal	Engine Temperature Sensor Open or Short Circuit - Test
4765-4	Aftertreatment #1 Diesel Oxidation Catalyst Intake Gas Temperature : Voltage Below Normal	Engine Temperature Sensor Open or Short Circuit - Test
5319-31	Aftertreatment 1 Diesel Particulate Filter Incomplete Regeneration	Diesel Particulate Filter Active Regeneration Was Interrupted
5419-7	Engine Throttle Actuator #1 : Not Responding Properly	Motorized Valve - Test
5571-7	High Pressure Common Rail Fuel Pressure Relief Valve : Not Responding Properly	Fuel Rail Pressure Problem
5571-16	High Pressure Common Rail Fuel Pressure Relief Valve : High - moderate severity (2)	Fuel Rail Pressure Problem

CAT C3.4B Engine Parts

Contact phone: 269 673 1638

Email: EngineParts@HeavyEquipmentRestorationParts.com

Alternate email: engineparts2@gmail.com

Website: www.CATC34B.com

Related website: www.HeavyEquipmentRestorationParts.com

www.FPTIndustrialEngineParts.com



Previous Screen



Troubleshooting
C3.4B Engines

Media Number -UENR0611-10

Publication Date -01/02/2015

i06091277

Diesel Particulate Filter Active Regeneration Occurrence Is Excessive

SMCS - 108F-035

Note: This procedure is only applicable to engines equipped with a wall flow Diesel Particulate Filter (DPF) and a DPF differential pressure sensor.

An active regeneration of the DPF will normally be initiated by the soot model that is calculated in the Electronic Control Module (ECM). If the differential pressure across the DPF is too high, the ECM will initiate an active regeneration based on the DPF differential pressure.

Probable Causes

- Insulation on the exhaust duct (if equipped)
- Diagnostic codes
- Incorrect wiring for temperature sensors
- Maintenance schedule
- Low compression (cylinder pressure)
- Electronic unit injectors
- Individual malfunctioning cylinders

Recommended Actions

Note: The procedures have been listed in order of probability. Complete the procedures in order.

Table 1

Troubleshooting Test Steps	Values	Results

<p>1. Insulation on the Exhaust Duct (if equipped)</p> <p>A. Check the insulation on the exhaust duct between the engine and the Clean Emissions Module (CEM). Make sure that insulation is not missing or damaged.</p>	<p>Codes</p>	<p>Result: The insulation is missing or damaged.</p> <p>Repair: Repair or replace the insulation.</p> <p>Result: The insulation is OK.</p> <p>Proceed to Test Step 2.</p>
<p>2. Diagnostic Codes</p> <p>A. Connect the electronic service tool to the diagnostic connector.</p> <p>B. Check for active diagnostic codes.</p> <p>C. Use the electronic service tool to perform a service regeneration.</p> <p>D. Check for active diagnostic codes on the electronic service tool.</p>	<p>Diagnostic codes</p>	<p>Result: There are active diagnostic codes.</p> <p>Repair: Investigate any active codes before continuing with this procedure. Refer to Troubleshooting, "Diagnostic Trouble Codes".</p> <p>Result: There are no active diagnostic codes.</p> <p>Proceed to Test Step 3.</p>
<p>3. Incorrect Wiring for Temperature Sensors</p> <p>A. Check that the Diesel Oxidation Catalyst (DOC) inlet temperature sensor and DPF inlet temperature sensor wiring has not been switched.</p> <p>Note: The engine may run without indicating a fault for many hours with this condition.</p> <p>B. Check that the wiring for the DOC inlet temperature and the DPF inlet temperature sensor is connected to the correct ECM pins. Refer to the Electrical Schematic for the application.</p>	<p>Wiring</p>	<p>Result: The wiring for the DOC inlet temperature sensor or the DPF inlet temperature sensor is incorrect.</p> <p>Repair: Repair the faulty wiring or replace the faulty wiring.</p> <p>Result: The wiring for the DOC inlet temperature sensor and the DPF inlet temperature sensor is OK.</p> <p>Proceed to Test Step 4.</p>
<p>4. Maintenance Schedule</p> <p>A. Check the maintenance schedule for the DPF. Refer to the Operation and Maintenance Manual, "Maintenance Interval</p>	<p>Maintenance schedule</p>	<p>Result: The DPF is due for an ash service.</p> <p>Repair: Perform an ash service. Refer to the Operation and Maintenance Manual, "Diesel</p>

Schedule".		Particulate Filter - Clean". Result: The DPF is not due for an ash service. Proceed to Test Step 5.
5. Low Compression (Cylinder Pressure) A. Perform a compression test. Refer to Systems Operation, Testing, and Adjusting, "Compression - Test ".	Low compression	Result: Low compression is recorded on one or more cylinders. Repair: Possible causes of low compression are shown in the following list: <ul style="list-style-type: none"> · Loose glow plugs · Faulty piston · Faulty piston rings · Worn cylinder bores · Worn valves · Faulty cylinder head gasket · Damaged cylinder head Make any repairs, as necessary. Result: No faults found. Proceed to Test Step 6.
6. Individual Malfunctioning Cylinders A. With the engine speed at a fast idle, use the electronic service tool to perform the manual "Cylinder Cut Out Test". As each cylinder is cut out, listen for a change in the sound from the engine. When a cylinder is cut out, there should be a noticeable change in the sound of the engine.	Cylinders	Result: There is not a noticeable change in the sound of the engine for at least one cylinder. Repair: Investigate the cause of the fault on any cylinder that is not operating. Investigate the cause of the fault on any cylinder that is operating below normal performance. Result: There is a noticeable change in the sound of the engine for each cylinder. Contact the Dealer Solution Network (DSN).

CAT C3.4B Engine Parts

Contact phone: 269 673 1638

Email: EngineParts@HeavyEquipmentRestorationParts.com

Alternate email: engineparts2@gmail.com

Website: www.CATC34B.com

Related website: www.HeavyEquipmentRestorationParts.com

www.FPTIndustrialEngineParts.com



Previous Screen



Troubleshooting
C3.4B Engines

Media Number -UENR0611-10

Publication Date -01/02/2015

i05992289

Diesel Particulate Filter Active Regeneration Was Interrupted

SMCS - 108F-035

This procedure covers the following diagnostic code:

Table 1

Diagnostic Trouble Code for Diesel Particulate Filter (DPF) Active Regeneration Interrupted		
J1939 Code	Description	Notes
5319-31	Aftertreatment 1 Diesel Particulate Filter Incomplete Regeneration	The Electronic Control Module (ECM) has interrupted an active regeneration. The maximum duration for an active regeneration has been exceeded three times. If equipped, the warning lamp will flash. The engine will be derated. The ECM will log the diagnostic code. The code will become inactive once a successful active regeneration has occurred.

Perform the following steps:

Recommended Actions

Note: The procedures have been listed in order of probability. Complete the procedures in order.

Table 2

Troubleshooting Test Steps	Values	Results

<p>1. Diagnostic Codes</p> <p>A. Establish communication between the electronic service tool and the Electronic Control Module (ECM).</p> <p>B. Check for active diagnostic codes.</p>	<p>Codes</p>	<p>Result: A diagnostic trouble code is active or logged.</p> <p>Troubleshoot any diagnostic codes that could have caused an unsuccessful regeneration before continuing with this procedure.</p> <p>Result: A diagnostic trouble code is not active or logged.</p> <p>Proceed to Test Step 2.</p>
<p>2. Insulation on the Exhaust Duct (If Equipped)</p> <p>A. Check the insulation on the exhaust duct between the engine and the Clean Emissions Module (CEM). Make sure that insulation is not missing or damaged.</p>	<p>Insulation</p>	<p>Result: The insulation is missing or damaged.</p> <p>Repair or replace the insulation on the exhaust duct.</p> <p>Result: The insulation is OK.</p> <p>Proceed to Test Step 3.</p>
<p>3. Exhaust Leaks</p> <p>A. Thoroughly inspect the exhaust duct between the engine and the CEM for leaks. Ensure that all connections are secure and no leaks are present.</p>	<p>Exhaust leaks</p>	<p>Result: There are exhaust leaks.</p> <p>Make the necessary repairs, Verify that the repair has eliminated the fault.</p> <p>Result: The exhaust duct is OK.</p> <p>Proceed to Test Step 4.</p>
<p>4. Manual Regeneration</p> <p>A. Use one of the following methods to perform a manual regeneration:</p> <ul style="list-style-type: none"> · The "Force Regeneration" switch on the application (if equipped) · The "Particulate Filter Forced Regeneration" on the electronic service tool <p>B. Use the electronic service tool to clear all logged diagnostic codes.</p>	<p>Complete regeneration</p>	<p>Result: The regeneration completed successfully and there are no active diagnostic codes.</p> <p>Return the engine to service.</p> <p>Result: The regeneration did not complete successfully.</p> <p>Contact the Dealer Solution Network (DSN).</p>

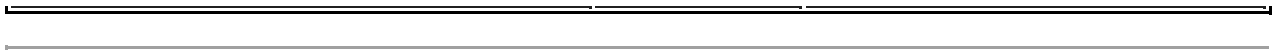



Previous Screen



Troubleshooting

C3.4B Engines

Media Number -UENR0611-10

Publication Date -01/02/2015

i06091309

Diesel Particulate Filter Collects Excessive Soot

SMCS - 108F-035

This procedure covers the following diagnostic code:

Note: This procedure is applicable to engines equipped with a wall flow DPF only.

Table 1

Diagnostic Trouble Codes for Diesel Particulate Filter (DPF) Collects Excessive Soot		
J1939 Code	Description	Notes
3251-16	Particulate Trap Differential Pressure : High - moderate severity (2)	<p>The Electronic Control Module (ECM) detects the following conditions:</p> <p>The differential pressure across the DPF is high for at least 100 seconds. The pressure at which this code becomes active is dependent on the level of soot indicated by the soot model that is calculated by the ECM.</p> <p>The battery voltage is at least 10 VDC.</p> <p>If equipped, the warning lamp will flash. The engine will be derated.</p>
3251-0	Particulate Trap Differential Pressure : High - most severe (3)	<p>The Electronic Control Module (ECM) detects the following conditions:</p> <p>The differential pressure across the DPF is very high for at least 100 seconds. The pressure at which this code becomes active is dependent on the level of soot indicated by the soot model that is calculated by the ECM.</p>

		The battery voltage is at least 10 VDC. If equipped, the warning lamp will flash and the shutdown lamp will come on.
3719-0	Aftertreatment 1 Diesel Particulate Filter Soot Load Percent : High - most severe (3)	The ECM detects that the soot level in the DPF is high. The warning lamp will come on.
3719-16	Aftertreatment 1 Diesel Particulate Filter Soot Load Percent : High - moderate severity (2)	The ECM detects that the soot load in the DPF is very high. The warning lamp will flash. The engine may be derated.

The Electronic Control Module (ECM) uses the Diesel Particulate Filter (DPF) differential pressure sensor to monitor the soot load in the DPF. An excessive accumulation of soot in the DPF can be caused by the following faults:

Probable Causes

- Faulty injectors
- Incorrect Wiring for Temperature Sensors
- Individual malfunctioning cylinders
- Low exhaust gas temperature
- A faulty valve in the NOx Reduction System (NRS)

Recommended Actions

Note: The procedures have been listed in order of probability. Complete the procedures in order.

Note: Engine operation must be kept to a minimum in order to minimize the amount of soot that is created. Follow the troubleshooting procedure in order to minimize the amount of engine operation.

Table 2

Troubleshooting Test Steps	Values	Results
<p>1. Diagnostic Codes</p> <p>A. Establish communication between the electronic service tool and the Electronic Control Module (ECM).</p> <p>B. Check for active diagnostic codes. Check specifically for codes that relate to the</p>	Diagnostic codes	<p>Result: A diagnostic trouble code is active or logged.</p> <p>Repair: Troubleshoot any related diagnostic codes before continuing with this procedure.</p> <p>Result: A related diagnostic</p>

<p>"Probable Causes" in this procedure.</p>		<p>trouble code is not active or logged.</p> <p>Proceed to Test Step 2.</p>
<p>2. Incorrect Wiring for Temperature Sensors</p> <p>A. Check that the Diesel Oxidation Catalyst (DOC) inlet temperature sensor and DPF inlet temperature sensor wiring has not been switched.</p> <p>Note: The engine may run without indicating a fault for many hours with this condition.</p> <p>B. Check that the wiring for the DOC inlet temperature and the DPF inlet temperature sensor is connected to the correct ECM pins. Refer to the Electrical Schematic for the application.</p>	<p>Wiring</p>	<p>Result: The wiring for the DOC inlet temperature sensor or the DPF inlet temperature sensor is incorrect.</p> <p>Repair: Repair the faulty wiring or replace the faulty wiring.</p> <p>Result: The wiring for the DOC inlet temperature sensor and the DPF inlet temperature sensor is OK.</p> <p>Proceed to Test Step 3.</p>
<p>3. Individual Malfunctioning Cylinders</p> <p>If the engine will run, perform the following steps.</p> <p>A. With the engine speed at a fast idle, use the electronic service tool to perform the manual "Cylinder Cut Out Test". As each cylinder is cut out, listen for a change in the sound from the engine. When a cylinder is cut out, there should be a noticeable change in the sound of the engine.</p>	<p>Insulation</p>	<p>Result: There is not a noticeable change in the sound of the engine for at least one cylinder.</p> <p>Repair: Investigate the cause of the fault on any cylinder that is not operating. Investigate the cause of the fault on any cylinder that is operating below normal performance. When all faults have been rectified, proceed to Test Step 4.</p> <p>Result: There is a noticeable change in the sound of the engine for each cylinder.</p> <p>Proceed to Test Step 4.</p>
<p>4. Exhaust Leaks</p> <p>A. Thoroughly inspect the exhaust duct between the engine and the CEM for leaks. Ensure that all connections are secure and no</p>	<p>Exhaust leaks</p>	<p>Result: There are exhaust leaks. The insulation is damaged.</p> <p>Repair: Make the necessary</p>

<p>leaks are present.</p> <p>B. Inspect the insulation on the exhaust duct (if equipped) for damage.</p>		<p>repairs. Proceed to Test Step 5.</p> <p>Result: The exhaust duct is OK.</p> <p>Proceed to Test Step 5.</p>
<p>5. Manual Regeneration</p> <p>A. If a 3251-16 or 3719-16 diagnostic code was active, use the electronic service tool to perform a "Particulate Filter Forced Regeneration". Make sure that the high soot loading diagnostic trouble code is no longer active.</p> <p>B. If a 3251-0 or 3719-0 diagnostic code was active, the DPF must be replaced. Refer to Disassembly and Assembly, "Diesel Particulate Filter - Remove" and refer to Disassembly and Assembly, "Diesel Particulate Filter - Install". Use the electronic service tool to perform the "DPF Replacement Reset".</p>	<p>Complete regeneration</p>	<p>Result: The regeneration completed successfully and there are no active diagnostic codes.</p> <p>Return the engine to service.</p> <p>Result: The regeneration did not complete successfully.</p> <p>Contact the Dealer Solution Network (DSN).</p>

CAT C3.4B Engine Parts
Contact phone: 269 673 1638
Email: EngineParts@HeavyEquipmentRestorationParts.com
Alternate email: engineparts2@gmail.com
Website: www.CATC34B.com
Related website: www.HeavyEquipmentRestorationParts.com
www.FPTIndustrialEngineParts.com



Previous Screen



Troubleshooting
C3.4B Engines

Media Number -UENR0611-10

Publication Date -01/02/2015

i05995809

Diesel Particulate Filter Has Differential Pressure Problem

SMCS - 108F-035

Note: This procedure is only applicable to engines equipped with a wall flow Diesel Particulate Filter (DPF) and a DPF differential pressure sensor.

This procedure covers the following diagnostic codes:

Table 1

Diagnostic Trouble Codes for the DPF Differential Pressure		
J1939 Code	Description	Notes
3251-7	Particulate Trap Differential Pressure : Not Responding Properly	<p>The Electronic Control Module (ECM) detects the following conditions:</p> <p>The measured differential pressure from the DPF differential pressure sensor is invalid.</p> <p>The battery voltage is at least 10 VDC.</p> <p>This fault can be caused by damaged or blocked pipes to the DPF differential pressure sensor. If equipped, the warning lamp will come on. The engine will be derated.</p>
3251-10	Particulate Trap Differential Pressure : Abnormal Rate of Change	<p>The ECM detects the following conditions:</p> <p>The differential pressure across the DPF does not drop below 2.5 kPa (0.36 psi) after the engine has stopped.</p> <p>This code will be active when the defect has been detected for at least 6 seconds.</p>

		<p>The battery voltage is at least 10 VDC.</p> <p>If equipped, the warning lamp will come on.</p> <p>The engine will be derated.</p> <p>The ECM detects the following conditions:</p>
3251-17	Particulate Trap Differential Pressure : Low - least severe (1)	There is no differential pressure across the DPF for at least 100 seconds.
3251-18	Particulate Trap Differential Pressure : Low - moderate severity (2)	<p>The battery voltage is at least 10 VDC.</p> <p>The engine will be derated.</p> <p>The fault will be cleared if the differential pressure is within the acceptable range for at least 10 seconds.</p>

The Electronic Control Module (ECM) uses the Diesel Particulate Filter (DPF) differential pressure sensor to monitor the soot load in the DPF. An excessive accumulation of soot in the DPF can be caused by the following faults:

Probable Causes

- Diagnostic codes
- Exhaust leaks
- Connections to the DPF differential pressure sensor
- Incorrect installation of the DPF
- Faulty DPF differential pressure sensor

Recommended Actions

Note: The procedures have been listed in order of probability. Complete the procedures in order.

Table 2

Troubleshooting Test Steps	Values	Results
<p>1. Diagnostic Codes</p> <p>A. Establish communication between -the electronic service tool and the Electronic Control Module (ECM).</p> <p>B. Check for active diagnostic codes. Check specifically for an active 3251-3 or 3251-4 diagnostic code.</p>	Diagnostic codes	<p>Result: A 3251-3 or 3251-4 diagnostic code is active</p> <p>Refer to Troubleshooting, "Sensor Signal (Analog, Active) - Test" before returning to this procedure.</p> <p>Result: A related diagnostic trouble code is not active or logged.</p> <p>Proceed to Test Step 2.</p>

<p>2. Exhaust Leaks</p> <p>A. Thoroughly inspect the exhaust duct between the engine and the DPF for leaks. Ensure that all connections are secure and no leaks are present.</p>	<p>Exhaust leaks</p>	<p>Result: There are leaks in the exhaust system.</p> <p>Make any necessary repairs.</p> <p>Result: The exhaust system is OK.</p> <p>Proceed to Test Step 3.</p>
---	----------------------	--

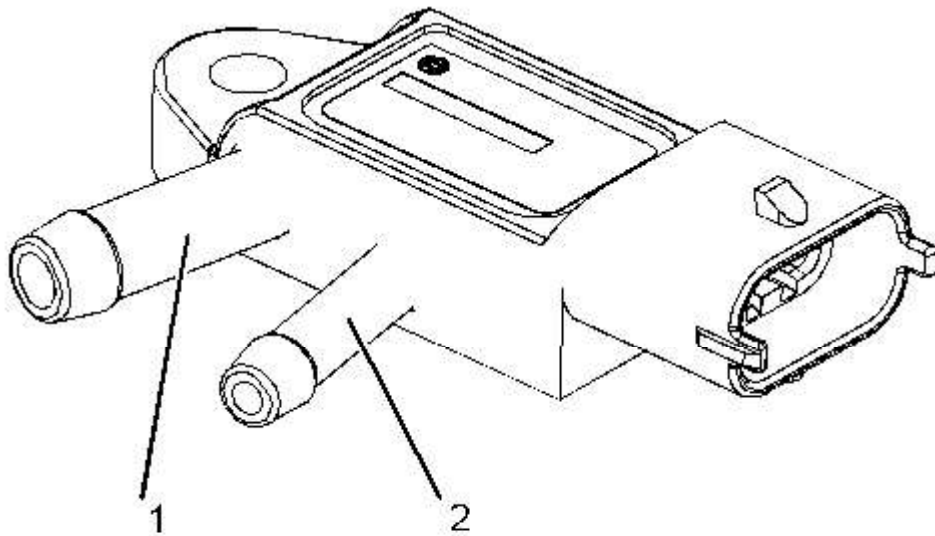

Illustration 1

g02726855

Typical view of the DPF differential pressure sensor

- (1) Connection to the DPF inlet
- (2) Connection to the DPF outlet

Table 3

Troubleshooting Test Steps	Values	Results
<p>3. Connections to the DPF Differential Pressure Sensor</p> <p>A. Thoroughly inspect the following components for blockages and/or damage:</p> <ul style="list-style-type: none"> • Connection (1) on the DPF differential pressure sensor • Connection (2) on the DPF differential pressure sensor • The pipes between the DPF 	<p>Damage and/or blockages</p>	<p>Result: One of the connections is damaged and/or blocked</p> <p>Replace any damaged or blocked components.</p> <p>Result: All connections are OK.</p> <p>Proceed to Test Step 4.</p>

<p>differential pressure sensor and the DPF</p> <ul style="list-style-type: none"> · The pipe connections on the DPF for the differential pressure sensor 		
<p>4. Incorrect Installation of the DPF</p> <p>A. Check that the DPF is installed correctly. Refer to Disassembly and Assembly, "Diesel Particulate Filter - Install" for the correct installation method for the DPF.</p>	<p>DPF</p>	<p>Result: The DPF is not installed correctly.</p> <p>Remove the DPF and install the DPF correctly. Refer to Disassembly and Assembly, "Diesel Particulate Filter - Remove" and Disassembly and Assembly, "Diesel Particulate Filter - Install".</p> <p>Result: The DPF is installed correctly.</p> <p>Install a replacement DPF differential pressure sensor.</p> <p>Run the engine and use the electronic service tool to check for active 3251 diagnostic codes.</p> <p>If the fault has not been eliminated, contact the Dealer Solution Network (DSN).</p>

CAT C3.4B Engine Parts

Contact phone: 269 673 1638

Email: EngineParts@HeavyEquipmentRestorationParts.com

Alternate email: engineparts2@gmail.com

Website: www.CATC34B.com

Related website: www.HeavyEquipmentRestorationParts.com

www.FPTIndustrialEngineParts.com



Troubleshooting

C3.4B Engines

Media Number -UENR0611-10

Publication Date -01/02/2015

i05980520

Diesel Particulate Filter Regeneration

SMCS - 108F

Regeneration

The wall-flow Diesel Particulate Filter (DPF) traps both soot and ash. Regeneration is the removal of soot from the DPF. The engine aftertreatment system is designed to oxidize the soot in the DPF at the same rate as the soot is produced by the engine. The oxidization of the soot will occur when the engine is operating under normal conditions. The soot in the DPF is constantly monitored. If the engine is operated in a way that produces more soot than the oxidized soot, the engine management system will automatically activate systems to raise the exhaust temperature.

The long-term buildup of ash is removed through a manual cleaning process. Refer to Operation and Maintenance Manual, "Diesel Particulate Filter - Clean" for more information on the service of the DPF. No service is required for the through-flow DPF.

For additional information on the regeneration of the DPF, refer to Systems Operation/Testing and Adjusting.

CAT C3.4B Engine Parts
Contact phone: 269 673 1638
Email: EngineParts@HeavyEquipmentRestorationParts.com
Alternate email: engineparts2@gmail.com
Website: www.CATC34B.com
Related website: www.HeavyEquipmentRestorationParts.com

www.FPTIndustrialEngineParts.com



Previous Screen



Troubleshooting
C3.4B Engines

Media Number -UENR0611-10

Publication Date -01/02/2015

i06092634

Diesel Particulate Filter Temperature Is Low

SMCS - 108F-035

The Electronic Control Module (ECM) monitors the temperature at the intake of the Diesel Particulate Filter (DPF).

Probable Causes

- Diagnostic codes
- Incorrect wiring for temperature sensors
- Insulation on the exhaust duct (if equipped)
- Exhaust leaks
- Wastegate

Recommended Actions

Note: The procedures have been listed in order of probability. Complete the procedures in order.

Table 1

Troubleshooting Test Steps	Values	Results
<p>1. Diagnostic Codes</p> <p>A. Establish communication between the electronic service tool and the Electronic Control Module (ECM).</p> <p>B. Check for active diagnostic codes.</p>	Codes	<p>Result: A diagnostic trouble code is active or logged.</p> <p>Repair: Troubleshoot any diagnostic codes before continuing with this procedure.</p> <p>Result: A diagnostic trouble code is not active or logged.</p>

		Proceed to Test Step 2.
<p>2. Incorrect Wiring for Temperature Sensors</p> <p>A. Check that the Diesel Oxidation Catalyst (DOC) inlet temperature sensor and DPF inlet temperature sensor wiring has not been switched.</p> <p>Note: The engine may run without indicating a fault for many hours with this condition.</p> <p>B. Check that the wiring for the DOC inlet temperature and the DPF inlet temperature sensor is connected to the correct ECM pins. Refer to the Electrical Schematic for the application.</p>	Wiring	<p>Result: The wiring for the DOC inlet temperature sensor or the DPF inlet temperature sensor is incorrect.</p> <p>Repair: Repair the faulty wiring or replace the faulty wiring.</p> <p>Result: The wiring for the DOC inlet temperature sensor and the DPF inlet temperature sensor is OK.</p> <p>Proceed to Test Step 3.</p>
<p>3. Insulation on the Exhaust Duct (If Equipped)</p> <p>A. Check the insulation on the exhaust duct between the engine and the Clean Emissions Module (CEM). Make sure that insulation is not missing or damaged.</p>	Insulation	<p>Result: The insulation is missing or damaged.</p> <p>Repair: Repair or replace the insulation on the exhaust duct.</p> <p>Result: The insulation is OK.</p> <p>Proceed to Test Step 4.</p>
<p>4. Exhaust Leaks</p> <p>A. Thoroughly inspect the exhaust duct between the engine and the CEM for leaks. Ensure that all connections are secure and no leaks are present.</p>	Exhaust leaks	<p>Result: There are exhaust leaks.</p> <p>Repair: Make the necessary repairs, Verify that the repair has eliminated the fault.</p> <p>Result: The exhaust duct is OK.</p> <p>Proceed to Test Step 5.</p>
<p>5. Wastegate</p> <p>A. Check for correct operation of the wastegate. Refer to Systems Operation, Testing, and Adjusting, "Turbocharger -</p>	Wastegate	<p>Result: The wastegate or the wastegate actuator is faulty.</p> <p>Repair: Install a replacement turbocharger. Refer to Disassembly and</p>

Inspect".

Assembly, "Turbocharger - Remove" and Disassembly and Assembly, "Turbocharger - Install".

Result: The wastegate and the wastegate actuator are OK.

Contact the Dealer Solution Network (DSN).

CAT C3.4B Engine Parts

Contact phone: 269 673 1638

Email: EngineParts@HeavyEquipmentRestorationParts.com

Alternate email: engineparts2@gmail.com

Website: www.CATC34B.com

Related website: www.HeavyEquipmentRestorationParts.com

www.FPTIndustrialEngineParts.com



Previous Screen



Troubleshooting

C3.4B Engines

Media Number -UENR061.1-10

Publication Date -01/02/2015

i06535538

ECM - Replace

SMCS - 1901-510

NOTICE

Keep all parts clean from contaminants.

Contaminants may cause rapid wear and shortened component life.

The engine is equipped with an Electronic Control Module (ECM). The ECM contains no moving parts. Follow the troubleshooting procedures in this manual to be sure that replacing the ECM will correct the problem. Verify that the suspect ECM is the cause of the problem.

Note: Ensure that the ECM is receiving power and that the ECM is properly grounded before replacement of the ECM is attempted. Refer to the schematic diagram.

Use the electronic service tool to read the parameters in the suspect ECM. Record the parameters in the suspect ECM. Install the flash file into the new ECM. After the ECM is installed on the engine, the parameters must be programmed into the new ECM.

NOTICE

If the flash file and engine application are not matched, engine damage may result.

Perform the following procedure to replace the ECM.

1. Connect the electronic service tool to the diagnostic connector.
2. From the menu bar go to the following menu options:
 - Service
 - Copy Configuration
 - ECM Replacement
3. Click "Load From File" at the bottom of the screen.
4. Once the ECM data has been loaded, click "Save to File" at the bottom of the screen. Select a folder location and click "Save".
5. Remove the ECM. Refer to Disassembly and Assembly, "Electronic Control Module - Remove and Install".
6. Install the replacement ECM. Refer to Disassembly and Assembly, "Electronic Control Module - Remove and Install".
7. Install the software on the new ECM. Refer to Troubleshooting , ECM Software - Install.
8. From the menu bar go to the following menu options:
 - Service
 - Copy Configuration
 - ECM Replacement
9. Click "Load From File" at the bottom of the screen.
10. Select the correct ECM replacement file. Check that the date and time stamp matches that of the desired replacement file and click "OK".
11. Click "Program ECM" at the bottom of the screen.
12. Once the "Programming Complete" dialog box appears on-screen, click "OK".
13. Check for logged diagnostic codes.



Previous Screen



Troubleshooting

C3.4B Engines

Media Number -UENR0611-10

Publication Date -01/02/2015

106580077

ECM Memory - Test

SMCS - 1901-038

This procedure covers the following diagnostic codes:

Table 1

Diagnostic Trouble Code for the ECM Memory		
J1939 Code	Description	Notes
152-2	Number Of ECU Resets : Erratic, Intermittent, or Incorrect	The software in the Electronic Control Module (ECM) has reset when the engine was running. There may be a brief loss of electrical power. The indicator lamps may come on for 2 seconds (lamp test).
166-2	Engine Rated Power : Erratic, Intermittent, or Incorrect	The ECM has detected an error during a software upgrade. If equipped, the warning lamp will come on.
166-14	Engine Rated Power : Special Instruction	The ECM has detected a rating mismatch in the software. If equipped, the warning lamp will flash and the shutdown lamp will come on. The engine will be shut down. The engine will not start.
1221-2	Continuously Monitored Systems Support/Status: Erratic, Intermittent, or Incorrect	The ECM continuously monitors the operating conditions of the engine. If there is an irregularity that is not detected by the engine sensor diagnostics, this code will become active.

		If equipped, the warning lamp will come on.
2840-12	ECU Instance : Failure	The ECM detects that the flash file that is installed is invalid. If equipped, the warning lamp will come on.

Table 2

Troubleshooting Test Steps	Values	Results
<p>1. Check for Active or Recently Logged Diagnostic Codes</p> <p>A. Connect the electronic service tool to the diagnostic connector. Refer to Troubleshooting, "Electronic Service Tools".</p> <p>B. Turn the keyswitch to the ON position. If the engine will start, then run the engine.</p> <p>C. Monitor the electronic service tool for active and/or recently logged diagnostic codes.</p> <p>D. Turn the keyswitch to the OFF position.</p>	Diagnostic codes	<p>Result: A 1221-2 diagnostic code is active or recently logged.</p> <p>Repair: Make a note of all other active or recently logged diagnostic codes. Troubleshoot all other codes before continuing this procedure. Refer to Troubleshooting, "Diagnostic Trouble Codes". If 1221-2 is the only active or recently logged diagnostic code, proceed to Test Step 2.</p> <p>Result: A 152-2 diagnostic code is active or recently logged.</p> <p>Repair: Make a note of all other active or recently logged diagnostic codes. Troubleshoot all other codes before continuing this procedure. Refer to Troubleshooting, "Diagnostic Trouble Codes". If 152-2 is the only active or recently logged diagnostic code, proceed to Test Step 3.</p> <p>Result: A 166-X or 2840-12 diagnostic code is active or recently logged.</p> <p>Proceed to Test Step 4.</p>
<p>2. Clear the Diagnostic Code and Attempt to Start the Engine</p> <p>A. Use the electronic service tool to clear the 1221-2 diagnostic code.</p> <p>B. Turn the keyswitch to the ON position. If the engine will start, then run the</p>	1221-2 diagnostic code	<p>Result: The 1221-2 diagnostic code is no longer active.</p> <p>Return the engine to service.</p> <p>Result: The 1221-2 diagnostic code is still active.</p>

<p>engine for at least 10 minutes.</p> <p>C. Operate the engine over the full duty cycle to replicate the conditions in which the fault occurred.</p> <p>D. Stop the engine. Turn the keyswitch to the ON position.</p> <p>E. Use the electronic service tool to check for an active or recently logged 1221-2 diagnostic code.</p>		<p>Proceed to Test Step 3.</p>
<p>3. Check the Battery Supply Voltage to the ECM</p> <p>A. Check that the ECM is receiving the correct battery voltage. Refer to Troubleshooting, "Electrical Power Supply - Test".</p>	<p>Battery voltage</p>	<p>Result: The ECM is receiving the correct voltage.</p> <p>Proceed to Test Step 4.</p> <p>Result: Make any necessary repairs. Refer to Troubleshooting, "Electrical Power Supply - Test".</p> <p>Use the electronic service tool to clear all logged diagnostic codes and verify that the repair eliminates the fault.</p> <p>If the diagnostic code is still active, proceed to Test Step 4.</p>
<p>4. Re-Flash the ECM</p> <p>A. Ensure that the correct rating of flash file for the engine is installed.</p> <p>B. Ensure that the latest software is installed on the ECM. Refer to Troubleshooting, "ECM Software - Install".</p> <p>C. Turn the keyswitch to the ON position.</p> <p>D. Use the electronic service tool to check for active diagnostic codes.</p> <p>E. Turn the keyswitch to the OFF position.</p>	<p>Diagnostic codes</p>	<p>Result: The diagnostic code is no longer active.</p> <p>Use the electronic service tool to clear all logged diagnostic codes.</p> <p>Return the engine to service.</p> <p>Result:The diagnostic code is still active.</p> <p>Proceed to Test Step 5.</p>

<p>5. Check if a Replacement ECM Eliminates the Fault</p> <p>A. Contact the Dealer Solution Network (DSN).</p> <p>B. If the Dealer Solution Network (DSN) recommends the use of a replacement ECM, install a replacement ECM. Refer to Troubleshooting, "ECM - Replace".</p> <p>C. Use the electronic service tool to recheck the system for active diagnostic codes.</p>	<p>Diagnostic codes</p>	<p>Result: There are no active diagnostic codes with the replacement ECM.</p> <p>Repair: Reconnect the suspect ECM. If the fault returns with the suspect ECM, replace the ECM.</p> <p>Use the electronic service tool to clear all logged diagnostic codes and then verify that the repair eliminates the fault.</p> <p>Result: The diagnostic code is still present with the replacement ECM.</p> <p>Contact the Dealer Solution Network (DSN).</p>
---	-------------------------	--



Troubleshooting

C3.4B Engines

Media Number -UENR0611-10

Publication Date -01/02/2015

i06146657

ECM Software - Install

SMCS - 1901-591; 7620-012

Flash Programming - A method of loading a flash file into the Electronic Control Module (ECM)

The electronic service tool is utilized to flash program a flash file into the ECM. The flash programming transfers the flash file from the PC to the ECM.

Use this process to program the engine flash file to the existing engine ECM. If the ECM is being replaced, refer to Troubleshooting, "ECM - Replace" to flash program a blank ECM.

Saving the Engine Configuration Data

Note: Save the engine configuration data before beginning the ECM flashing process in order to avoid losing the engine configuration data.

1. Connect the electronic service tool to the diagnostic connector.
2. From the menu bar go to the following menu options:
 - Service
 - Copy Configuration
 - ECM Replacement
3. Click on "Load From ECM" at the bottom of the screen.
4. Once the ECM data has been loaded, click on "Save to File" at the bottom of the screen. Select a folder location and click on "Save".

Flash Programming a Flash File Using "WinFlash"

1. Obtain the part number for the new flash file.

Note: If you do not have the part number for the flash file, use the "Flash File Search" tool on the Service Technician Workbench (STW). Alternatively, use the "Flash Software Files" feature on SIS Web.

Note: You must have the engine serial number in order to search for the part number of the flash file.

2. Connect the electronic service tool to the diagnostic connector.
3. Turn the keyswitch to the ON position. Do not start the engine.
4. Select "WinFlash" from the "Utilities" menu on the electronic service tool.
5. Flash program the flash file into the ECM.

- a. Select the engine ECM under the "Detected ECMs".

Note: If "WinFlash" will not communicate with the engine ECM, proceed to "Loading the Engine Configuration Data".

- b. Press the "Browse" button in order to select the part number of the flash file that will be programmed into the ECM.
- c. When the correct flash file is selected, press the "Open" button.
- d. Verify that the "File Values" match the application. If the "File Values" do not match the application, search for the correct flash file.
- e. When the correct flash file is selected, press the "Begin Flash" button.
- f. The electronic service tool will indicate when flash programming has been successfully completed.

6. Proceed to "Loading the Engine Configuration Data"

"WinFlash" Error Messages

If any error messages are displayed during flash programming, click on the "Cancel" button in order to stop the process. Access the information about the "ECM Summary" under the "Information" menu. Ensure that you are programming the correct flash file for your engine.

Flash Programming the ECM Using "ECM Flash"

1. Download the flash file that is to be installed.

Note: When using version **2015A** or earlier of the electronic service tool, contact the Dealer Solutions Network (DSN) in order to obtain the flash file in the correct format.

2. Connect the electronic service tool to the diagnostic connector. If necessary, refer to Troubleshooting, "Electronic Service Tools".
3. Navigate to the following menu options in the electronic service tool:
 - Utilities
 - ECM Flash
4. Click on "Select File" on the bottom left of the screen. Navigate to the location of the flash file to be installed. Once the flash file has been selected, the flash file information will be displayed.
5. Click on "Start Download" to begin the installation process.
6. Proceed to "Loading the Engine Configuration Data"

Note: If "WinFlash" or "ECM Flash" will not communicate with the ECM, refer to Troubleshooting, "Electronic Service Tool Does Not Communicate".

Loading the Engine Configuration Data

1. From the menu bar go to the following menu options:
 - Service
 - Copy Configuration
 - ECM Replacement
 2. Click on "Load From File" at the bottom of the screen.
 3. Select the correct ECM replacement file. Check that the date and time stamp matches that of the desired replacement file and click on "OK".
 4. Click on "Program ECM" at the bottom of the screen.
 5. Once the "Programming Complete" dialog box appears on screen, click on "OK".
 6. Access the "Configuration" screen under the "Service" menu in order to determine the parameters that require programming.
 7. Start the engine and check for proper operation. Check that there are no active diagnostic codes.
-



Troubleshooting

C3.4B Engines

Media Number -UENR0611-10

Publication Date -01/02/2015

i06233954

Electrical Connectors - Inspect

SMCS - 7553-040-WW

Most electrical faults are caused by poor connections. The following procedure will assist in detecting faults with connectors and with wiring. If a fault is found, correct the condition and verify that the fault is resolved.

Intermittent electrical faults are sometimes resolved by disconnecting and reconnecting connectors. It is very important to check for diagnostic codes immediately before disconnecting a connector. Also check for diagnostic codes after reconnecting the connector. If the status of a diagnostic code is changed due to disconnecting and reconnecting a connector, there are several possible reasons. The likely reasons are loose terminals, improperly crimped terminals, moisture, corrosion, and inadequate mating of a connection.

Follow these guidelines:

- Never break the insulation of a wire in order to access a circuit for measurements.
- If a wire is cut, always install a new terminal for the repair.



WARNING

The connection of any electrical equipment and the disconnection of any electrical equipment may cause an explosion hazard which may result in injury or death. Do not connect any electrical equipment or disconnect any electrical equipment in an explosive atmosphere.

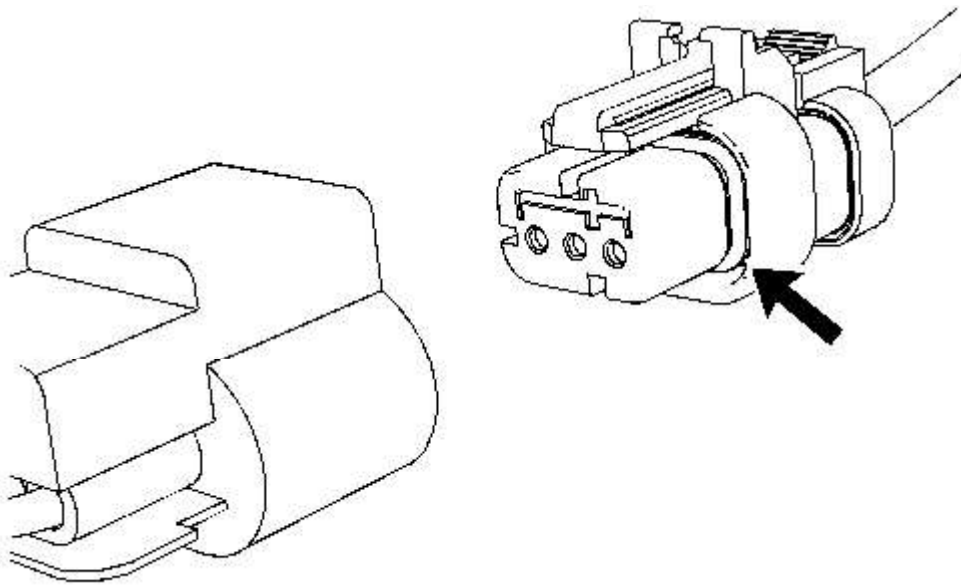

Illustration 1

g01131019

Seal for a three-pin connector (typical example)

Table 1

Troubleshooting Test Steps	Values	Results
<p>1. Check Connectors for Moisture and Corrosion</p> <p>A. Inspect all the harnesses. Ensure that the routing of the wiring harness allows the wires to enter the face of each connector at a perpendicular angle. Otherwise, the wire will deform the seal bore. This will create a path for the entrance of moisture. Verify that the seals for the wires are sealing correctly.</p> <p>B. Ensure that the sealing plugs are in place. If any of the plugs are missing, replace the plug. Ensure that the plugs are inserted correctly into the connector.</p> <p>C. Disconnect the suspect connector and inspect the connector seal. Ensure that the seal is in good condition. If necessary, replace the connector.</p> <p>D. Thoroughly inspect the connectors for evidence of moisture entry.</p> <p>Note: It is normal to see some minor seal abrasion on connector seals. Minor seal abrasion will not allow the entry of moisture.</p> <p>If moisture or corrosion is evident in the connector, the source of the moisture entry must be found and the source of the moisture entry must be repaired. If</p>	<p>Harness, connectors, and seals are OK.</p>	<p>Result: A fault has been found with the harness or the connectors.</p> <p>Repair: Repair the connectors or the wiring, as required. Ensure that all of the seals are correctly installed. Ensure that the connectors have been reattached. If corrosion is evident on the pins, sockets or the connector, use only denatured alcohol to remove the corrosion. Use a cotton swab or a soft brush to remove the corrosion. If moisture was found in the connectors, run the engine for several minutes and check again for moisture. If moisture reappears, the moisture is wicking into the connector. Even if the moisture entry path is repaired, it may be necessary to replace the wires. Use the electronic service tool in</p>

<p>the source of the moisture entry is not repaired, the fault will recur. Simply drying the connector will not rectify the fault. Check the following items for the possible moisture entry path:</p> <ul style="list-style-type: none"> · Missing seals · Incorrectly installed seals · Nicks in exposed insulation · Improperly mated connectors <p>Moisture can also travel to a connector through the inside of a wire. If moisture is found in a connector, thoroughly check the connector harness for damage. Also check other connectors that share the harness for moisture.</p> <p>Note: The ECM is a sealed unit. If moisture is found in an ECM connector, the ECM is not the source of the moisture. Do not replace the ECM.</p>		<p>order to clear all logged diagnostic codes and then verify that the repair eliminates the fault.</p> <p>Result: The harness, connectors, and seals are in good condition.</p> <p>Proceed to Test Step 2.</p>
<p>2. Check the Wires for Damage to the Insulation</p> <p>A. Carefully inspect each wire for signs of abrasion, nicks, and cuts.</p> <p>Inspect the wires for the following conditions:</p> <ul style="list-style-type: none"> · Exposed insulation · Rubbing of a wire against the engine · Rubbing of a wire against a sharp edge <p>B. Check all of the fasteners for the harness and the strain relief components on the ECM in order to verify that the harness is correctly secured. Also check all of the fasteners in order to verify that the harness is not compressed. Pull back the harness sleeves in order to check for a flattened portion of wire. A fastener that has been overtightened flattens the harness. This damages the wires that are inside the harness.</p>	<p>The wiring is OK</p>	<p>Result: There is damage to the harness.</p> <p>Repair: Repair the wires or replace the wires, as required. Use the electronic service tool in order to clear all logged diagnostic codes and then verify that the repair eliminates the fault.</p> <p>Result: The wires are free of abrasion, nicks, and cuts and the harness is correctly clamped.</p> <p>Proceed to Test Step 3.</p>
<p>3. Inspect the Connector Terminals</p> <p>A. Visually inspect each terminal in the connector. Verify that the terminals are not damaged. Verify that the terminals are correctly aligned in the connector and verify that the terminals are correctly located in the connector.</p>	<p>Terminals are aligned and undamaged</p>	<p>Result: The terminals of the connector are damaged.</p> <p>Repair: Repair the terminals and/or replace the terminals, as required. Use the electronic service tool in order to clear all logged diagnostic codes and then verify</p>

that the repair eliminates the fault.

Result: The terminals are OK.

Proceed to Test Step 4.

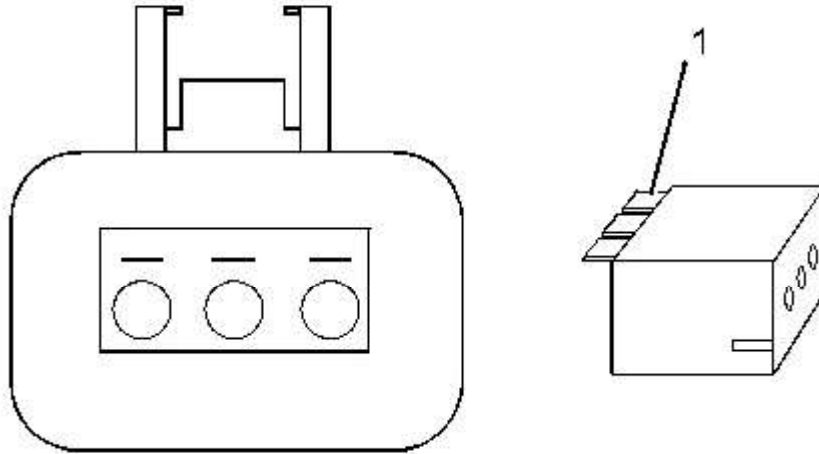

Illustration 2

g01802454

A typical example of the lock wedge.

(1) Lock wedge

Table 2

Troubleshooting Test Steps	Values	Results
<p>4. Perform a Pull Test on Each Wire Terminal Connection</p> <p>A. Ensure that the locking wedge for the connector is installed correctly. Terminals cannot be retained inside the connector if the locking wedge is not installed correctly.</p> <p>B. Perform the 30 N (6.7 lb) pull test on each wire. Each terminal and each connector should easily withstand 30 N (6.7 lb) of tension and each wire should remain in the connector body. This test checks whether the wire was correctly crimped in the terminal and whether the terminal was correctly inserted into the</p>	<p>Pull test OK</p>	<p>Result: A wire has been pulled from a terminal or a terminal has been pulled from the connector in the 30 N (6.7 lb) pull test.</p> <p>Repair: Replace the terminal. Replace damaged connectors, as required.</p> <p>Use the electronic service tool in order to clear all logged diagnostic codes and then verify that the repair eliminates the fault.</p> <p>Result: All terminals pass the</p>

connector.		pull test. Proceed to Test Step 5.
<p>5. Check Individual Pin Retention into the Socket</p> <p>A. Verify that the sockets provide good retention for the pins. Insert a new pin into each socket one at a time in order to check for a good grip on the pin by the socket.</p>	The sockets provide good retention for the new pin.	<p>Result: Terminals are damaged.</p> <p>Repair: Replace the damaged terminals. Verify that the repair eliminates the problem. Use the electronic service tool in order to clear all logged diagnostic codes and then verify that the repair eliminates the fault.</p> <p>Result: The terminals are OK.</p> <p>Proceed to Test Step 6.</p>
<p>6. Check the Locking Mechanism of the Connectors</p> <p>A. Ensure that the connectors lock correctly. After locking the connectors, ensure that the two halves cannot be pulled apart.</p> <p>B. Verify that the latch tab of the connector is correctly latched. Also verify that the latch tab of the connector returns to the locked position.</p>	The connectors are locked and are not damaged	<p>Result: The locking mechanism for the connector is damaged or missing.</p> <p>Repair: Repair the connector or replace the connector, as required. Use the electronic service tool in order to clear all logged diagnostic codes and then verify that the repair eliminates the fault.</p> <p>Result: The connectors are in good condition.</p> <p>Reconnect all connectors. If there are still active diagnostic codes, refer to Troubleshooting, "Diagnostic Trouble Codes".</p>



Previous Screen



Troubleshooting C3.4B Engines

Media Number -UENR0611-10

Publication Date -01/02/2015

i05981997

Electrical Connectors

SMCS - 7553-WW

Connectors for the Electronic Control Module (ECM)

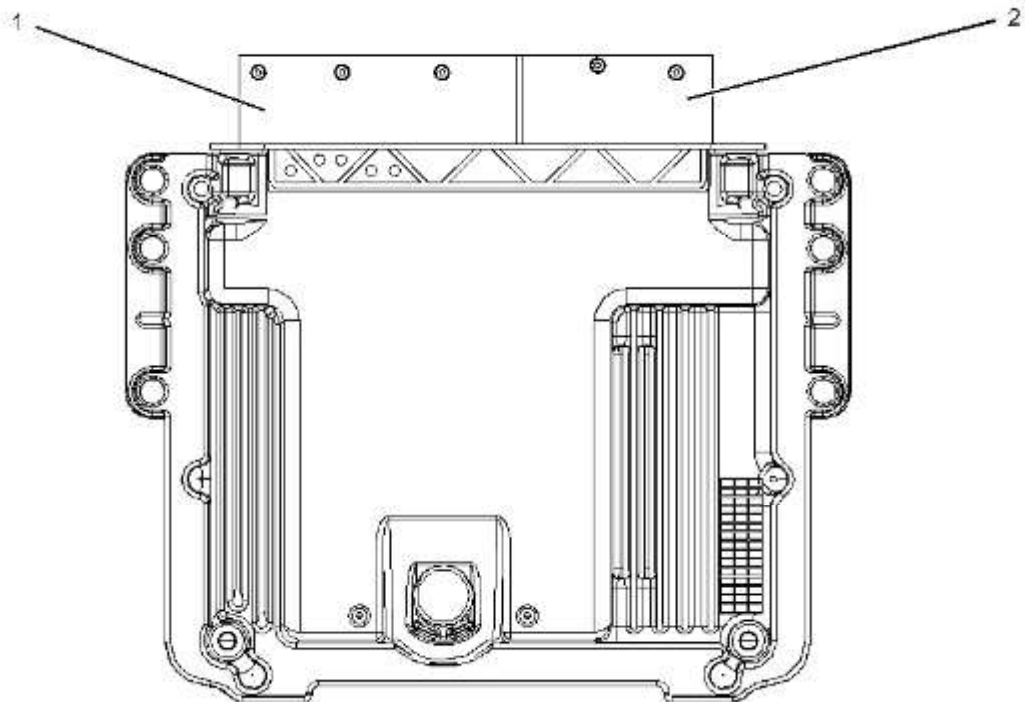

Illustration 1

g037470t

View of the engine ECM

(1) J1 ECM connector

(2) J2 ECM connector

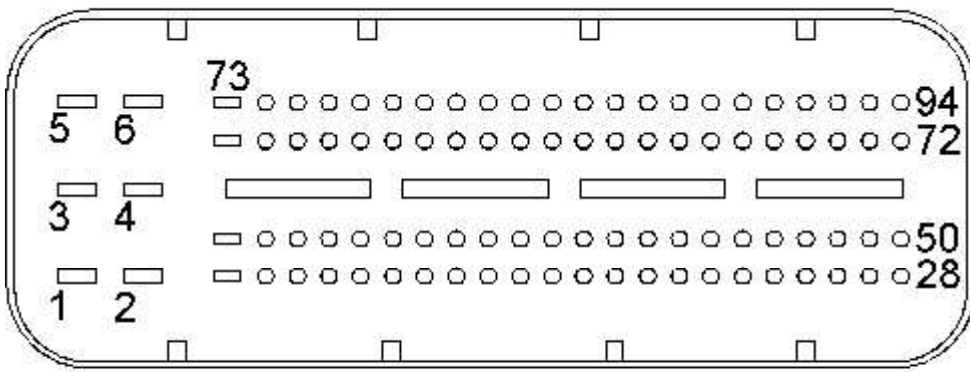

Illustration 2

g02277053

View of the J1 ECM connector (ECM side)

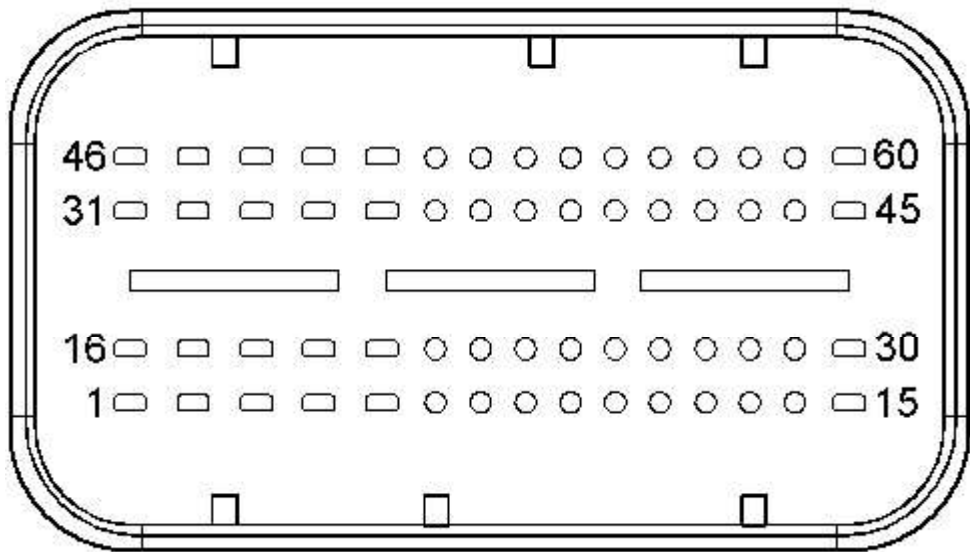

Illustration 3

g02266273

View of the J2 ECM connector (ECM side)



Previous Screen



Troubleshooting

C3.4B Engines

Media Number -UENR0611-10

Publication Date -01/02/2015

i06229707

Electrical Power Supply - Test

SMCS - 1401-038

This procedure tests that the correct voltage is being supplied to the Electronic Control Module (ECM).

This procedure covers the following codes:

Table 1

Diagnostic Trouble Codes for the Electrical Power Supply Circuit		
J1939 Code	Code Description	Notes
168-3	Battery Potential / Power Input 1 : Voltage Above Normal	<p>This code indicates that the battery circuit to the ECM has excessive voltage while the engine is running. The ECM detects the following conditions:</p> <p>The battery voltage is high for at least 5 seconds.</p> <p>The keyswitch is in the ON position.</p> <p>The engine is not cranking.</p> <p>The warning lamp will come on.</p>
168-4	Battery Potential / Power Input 1 : Voltage Below Normal	<p>This code indicates that the battery circuit for the ECM has low voltage while the engine is running. The ECM detects the following conditions:</p> <p>The battery voltage is low for at least 5 seconds.</p> <p>The keyswitch is in the ON position.</p>

The engine is not cranking.

The ECM will normally log the diagnostic code. If battery voltage disappears without returning, the ECM will not log this diagnostic code and the engine will shut down.

The engine may experience changes in the engine rpm, and intermittent engine shutdowns or complete engine shutdowns while the conditions that cause this diagnostic code are present.

Battery+ voltage is supplied through P1: 1, 3, and 5. The battery- is supplied through P1: 2, 4, and 6. The ECM receives the keyswitch signal at P1:54 when the keyswitch is in the ON position or in the START position. When the ECM detects battery voltage at this input, the ECM will activate the main relay. When battery voltage is removed from this input, after a short time (up to 60 seconds) the ECM will deactivate the main relay.

The cause of an intermittent power supply to the ECM can occur on either the positive side or on the negative side of the battery supply circuit.

Usually, battery power to the diagnostic connector is available and the battery power to the data link connector is independent of the keyswitch. Therefore, although the electronic service tool can be powered up, there may be no communication with the engine ECM. The engine ECM requires the keyswitch to be in the ON position in order to maintain communications. The ECM may power down a short time after connecting the electronic service tool if the keyswitch is in the OFF position.

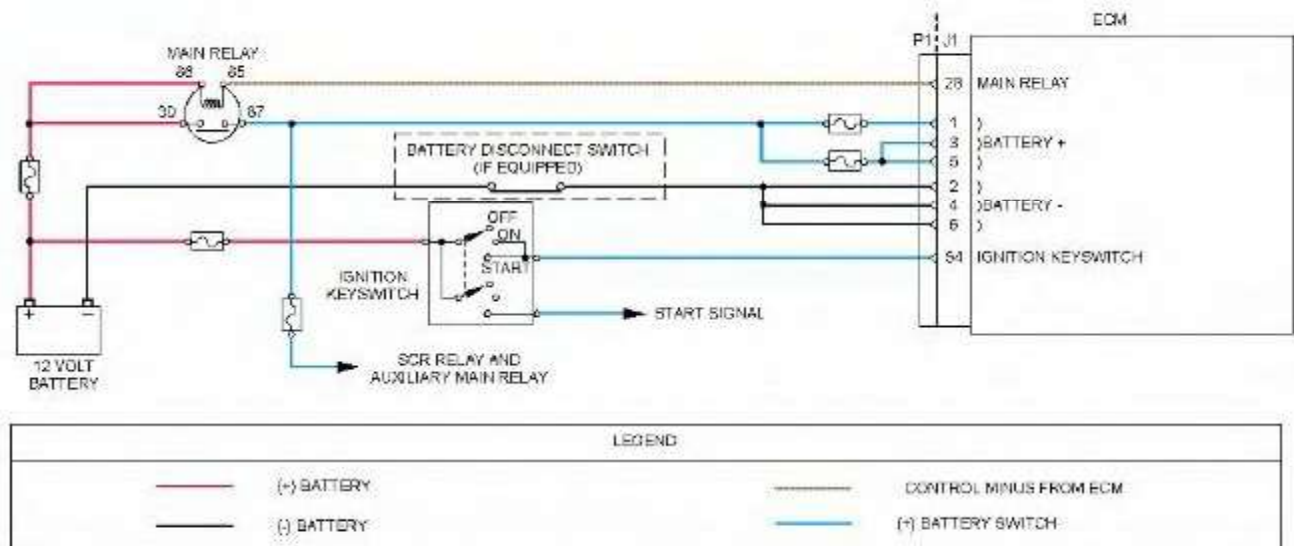

Illustration 1

Schematic diagram for the electrical power supply circuit

Not all connectors are shown. Refer to the Electrical Schematic for the application.

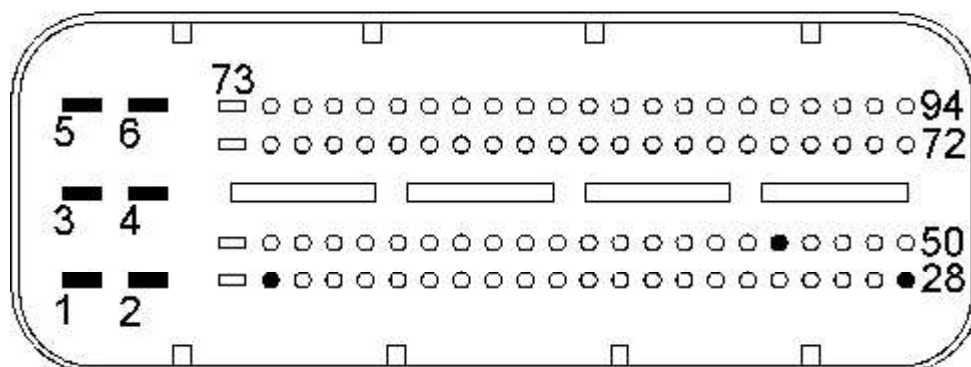

Illustration 2

g03722982

View of the pin locations on the P1 connector for the electrical power supply circuit

- (1) Battery+
- (2) Battery ground
- (3) Battery+
- (4) Battery ground
- (5) Battery+
- (6) Battery ground
- (8) Start Signal
- (28) ECM main relay
- (54) Ignition key switch

Table 2

Troubleshooting Test Steps	Values	Results
<p>1. Inspect Electrical Connectors and Wiring</p> <p>A. Check the fuses.</p> <p>B. Thoroughly inspect the battery connections and the connections to the relays. Refer to Troubleshooting, "Electrical Connector - Inspect" for details.</p> <p>C. Perform a 30 N (6.7 lb) pull test on each</p>	<p>Damaged wire or connector</p>	<p>Result: A damaged wire or damaged connector was found. A fuse is blown.</p> <p>Repair: Repair the damaged wire or the damaged connector. Replace any blown fuses</p> <p>Use the electronic service tool to clear all logged diagnostic codes. Verify that the repair eliminates the fault.</p> <p>Result: All connectors, pins, and sockets</p>

<p>of the wires in the ECM connector that are associated with electrical power supply circuit.</p> <p>D. Check the harness for abrasion and for pinch points from the battery to the ECM.</p>		<p>are correctly connected and/or inserted and the harness is free of corrosion, of abrasion or of pinch points.</p> <p>Proceed to Test Step 2.</p>
<p>2. Check for Active Diagnostic Codes or Logged Diagnostic Codes</p> <p>A. Connect the electronic service tool to the diagnostic connector.</p> <p>B. Turn the keyswitch to the ON position and start the engine.</p> <p>C. Monitor the active diagnostic code screen on the electronic service tool. Check and record any active diagnostic codes or logged diagnostic codes.</p> <p>Note: Wait at least 30 seconds in order for the diagnostic codes to become active.</p>	<p>Diagnostic codes</p>	<p>Result: There are no active 168 diagnostic codes at this time.</p> <p>Repair: If the fault is intermittent, refer to Troubleshooting, "Electrical Connector - Inspect". If the ECM is receiving no battery voltage, proceed to Test Step 3.</p> <p>Result: There is an active 168-3 diagnostic code.</p> <p>Proceed to Test Step 3.</p> <p>Result: There is an active 168-4 diagnostic code.</p> <p>Proceed to Test Step 4.</p>
<p>3. Check the Alternator</p> <p>A. Test the alternator for correct operation. Refer to Systems Operation, Testing and Adjusting, "Alternator - Test".</p>	<p>Alternator</p>	<p>Result: The alternator is faulty.</p> <p>Repair: Replace the alternator. Use the electronic service tool to clear all logged diagnostic codes and verify that the repair eliminates the fault.</p> <p>Result: The alternator is operating correctly.</p> <p>Proceed to Test Step 4.</p>
<p>4. Check the Battery</p> <p>A. Load-test the battery. Use a suitable battery load tester. Refer to Systems Operation, Testing and Adjusting, "Battery -</p>	<p>Battery load test passed</p>	<p>Result: The battery does not pass the load test. The measured voltage is less than 11 VDC.</p> <p>Repair: Recharge or replace the faulty battery.</p>

Test" for the correct procedure.

Use the electronic service tool in order to clear all logged diagnostic codes and then verify that the repair eliminates the fault.

Result: The battery passes the load test. The measured voltage is at least 11 V.

Repair: Check the wiring between the battery and the ECM. Refer to the Electrical Schematic for the application. Make any necessary repairs. If the fault is still present, contact the Dealer Solution Network (DSN).



Previous Screen



Troubleshooting

C3.4B Engines

Media Number -UENR061.1-10

Publication Date -01/02/2015

i06233880

Electronic Service Tool Does Not Communicate

SMCS - 0785; 1900

Probable Causes

- Configuration of the communications adapter
- Electrical connectors
- Communication adapter and/or cables
- Electrical power supply to the diagnostic connector
- Electronic service tool and related hardware
- Electrical power supply to the Electronic Control Module (ECM)

Recommended Actions

Note: The procedures have been listed in order of probability. Complete the procedures in order.

Table 1

Troubleshooting Test Steps	Values	Results
<p>1. Configuration of the Communications Adapter</p> <p>A. Access "Preferences" under the "Utilities" menu on the electronic service tool.</p>	<p>Communications adapter configuration</p>	<p>Result: The correct "Communications Interface Device" is not selected.</p> <p>Repair: Select the correct "Communications Interface Device".</p>

<p>B. Check for hardware that uses the same ports as the communications adaptor.</p>		<p>Result: The correct port is not selected for use by the communication adapter.</p> <p>Repair: Select the correct port for use by the communication adapter.</p> <p>Note: The most commonly used port is "COM 1".</p> <p>Result: Other hardware is sharing the same port with the communications adaptor.</p> <p>Repair: Exit or close the software programs for that device.</p> <p>Result: The communications adaptor is correctly configured.</p> <p>Proceed to Test Step 2.</p>
<p>2. Electrical Connectors</p> <p>A. Check for correct installation of the P1 and P2 ECM connectors and of the connector for the electronic service tool.</p>	<p>Electrical connectors</p>	<p>Result: The connectors are not correctly installed.</p> <p>Repair: Repair or replace the connectors, as necessary.</p> <p>Result: The connectors are OK.</p> <p>Proceed to Test Step 3.</p>
<p>3. Communication Adapter and/or Cables</p> <p>A. Check that the firmware and driver files are the most current files for the type of communication adapter that is being used.</p> <p>Verify that the correct cable is being used between the communication adapter and the diagnostic connector.</p> <p>B. Disconnect and then reconnect the cable that attaches the communication adapter to the diagnostic connector.</p>	<p>Comms adaptor and cables</p>	<p>Result: The firmware or driver files are not the most current files.</p> <p>Repair: Update the firmware or driver files to the most current files.</p> <p>Result: The cable between the communication adapter and the diagnostic connector is not correct.</p> <p>Repair: Replace the cable between the communication adapter and the diagnostic connector with the correct type.</p> <p>Result: The laptop computer has a</p>

<p>C. Check the operating system on the laptop computer.</p>		<p>Windows operating system.</p> <p>Repair: Restart the laptop computer in order to eliminate the possibility of a conflict in the software.</p> <p>Result: The adaptor and cables are OK.</p> <p>Proceed to Test Step 4.</p>
<p>4. Electrical Power Supply to the Diagnostic Connector</p> <p>A. Use a multimeter to check that battery voltage is present between terminals A and B of the diagnostic connector.</p> <p>Note: If the communication adapter is not receiving power, the LED display on the communication adapter will be off.</p>	<p>Electrical power</p>	<p>Result: Battery voltage is not present between terminals A and B of the diagnostic connector.</p> <p>Repair: Investigate the cause and repair, as necessary.</p> <p>Result: Battery voltage is present between terminals A and B of the diagnostic connector.</p> <p>Proceed to Test Step 5.</p>
<p>5. Electronic Service Tool and Related Hardware</p> <p>A. Connect the electronic service tool to a different engine.</p> <p>Note: This process eliminates the electronic service tool and the related hardware as the fault.</p>	<p>Hardware</p>	<p>Result: The same fault occurs on a different engine.</p> <p>Repair: Check the electronic service tool and the related hardware for faults.</p> <p>Result: The fault does not occur on a different engine.</p> <p>Proceed to Test Step 6.</p>
<p>6. Electrical Power Supply to the Electronic Control Module (ECM)</p> <p>A. Check the power supply to the ECM. Refer to Troubleshooting, "Electrical Power Supply - Test".</p> <p>Note: If the ECM is not receiving battery</p>	<p>Power to ECM</p>	<p>Result: The power supply to the ECM is incorrect.</p> <p>Repair: Investigate the cause and repair, as necessary.</p> <p>Result: The power supply to the ECM is OK.</p>

voltage, the ECM will not communicate.

Contact the Dealer Solution Network (DSN).



Previous Screen



Troubleshooting
C3.4B Engines

Media Number -UENR0611-10

Publication Date -01/02/2015

i05857076

Electronic Service Tools

SMCS - 0785

Caterpillar electronic service tools are designed to help the service technician perform the following tasks:

- Information access
- System diagnostics
- System calibrations
- System configurations
- Data link communications

Required Service Tools

Table 1

Required Service Tools	
Part Number	Description
6V-2197	Transducer
7X-1171	Transducer Adapter
5P-7277	Voltage Tester
7X-1710	Multimeter Probe
6V-7070	Digital Multimeter (HEAVY-DUTY)
	or
9U-7330	Digital Multimeter
	or

146-4080	Digital Multimeter Gp (RS232)
	or
212-2160	Digital Multimeter Gp

Optional Service Tools

Table 2 lists the optional service tools that can be used when the engine is serviced.

Table 2

Part Number	Description
198-4240 or 1U-5470	Digital Pressure Indicator Engine Pressure Group
4C-4911 ⁽¹⁾	Battery Load Tester
6V-9130 ⁽²⁾	Temperature Adapter (MULTIMETER)
215-9512 ⁽³⁾	Hose Connector (Quick Disconnect, Male)
215-9513	Hose Connector (Quick Disconnect, Female)
155-5176	AC/DC Current Probe
2P-8278	Tube As
217-0113	Harness As

⁽¹⁾ Refer to Special Instructions, SEHS9249, "Use of 4C-4911 Battery Load Tester for 6, 8, and 12 V Lead Acid Batteries" and Special Instructions, SEHS7633, "Battery Test Procedure".

⁽²⁾ Refer to Special Instructions, SEHS8382, "Use of the 6V-9130 Temperature Adapter Group".

⁽³⁾ This item is used with a 2P-8278 Tube Assembly.

Caterpillar Electronic Technician (ET)

Cat ET can display the following information:

- Status of all pressure sensors and temperature sensors
- Programmable parameter settings
- Active diagnostic codes and logged diagnostic codes
- Logged events
- Histograms

Cat ET can also be used to perform the following functions:

- Diagnostic tests

- Calibrations
- Programming of flash file
- Parameter programming
- Copy configuration function for Electronic Control Module (ECM) replacement
- Data logging
- Graphs (real time)

Table 3 lists the service tools that are required in order to use Cat ET.

Table 3

Standard Hardware for Connecting with Cat ET	
Part Number	Description
N/A	Personal Computer (PC)
317-7484	Communication Adapter Gp
Components of the 317-7484 Communication Adapter Gp	
317-7485	Communication Adapter (3)
370-4617	Cable As (USB)
457-6114	Cable As
Tool Operating Manual & Software CD ROM, NETG5057, "Communication Adapter 3"	

Note: More information on the use of Cat ET and the PC requirements is in the documentation that accompanies the Cat ET software.

Connecting Cat ET and the Communication Adapter Gp

Use the following procedure in order to connect Cat ET and the CA3 Communication Adapter.

1. Turn the keyswitch to the OFF position.
-

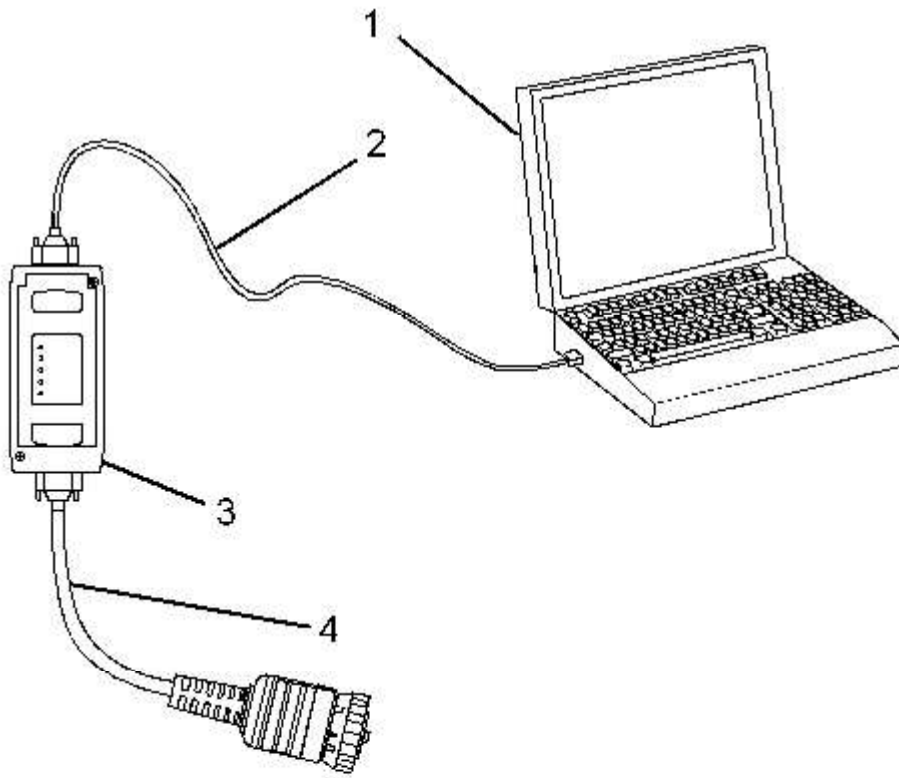

Illustration 1

g02051513

- (1) PC
 - (2) **353-5083** Cable As (USB)
 - (3) **317-7485** Communication Adapter (3)
 - (4) **457-6114** Cable As
2. Connect cable (2) between the "COMPUTER" end of CA3 adapter (3) and a USB port of PC (1).
 3. Connect cable (4) between the "DATA LINK" end of CA3 adapter (3) and the service tool connector.
 4. Place the keyswitch in the ON position. If the Electronic Service Tool and the CA3 adapter do not communicate with the Electronic Control Module (ECM), refer to the diagnostic procedure Troubleshooting, "Electronic Service Tool Does Not Communicate".
-



Previous Screen



Troubleshooting
C3.4B Engines

Media Number -UENR0611-10

Publication Date -01/02/2015

i06223543

Engine Cranks but Does Not Start

SMCS - 1000-035; 1450-035

Probable Causes

Note: Wait at least 30 seconds between attempts to start the engine. The engine will not start unless the keyswitch has been turned to the OFF position for at least 30 seconds.

- Ground level shutdown switch
- Diagnostic codes
- Visible faults
- Air intake and exhaust system
- Fuel system
- Fuel filters
- Fuel rail Pressure Relief Valve (PRV)
- Fuel pump timing
- Low compression (cylinder pressure)

Recommended Actions

Note: The procedures have been listed in order of probability. Complete the procedures in order.

Table 1

Troubleshooting Test Steps	Values	Results
1. Ground Level Shutdown Switch (If	Shutdown	Result: The ground level shutdown

<p>Equipped)</p> <p>A. Ensure that the ground level shutdown switch has not been activated.</p>	<p>switch</p>	<p>switch has been activated.</p> <p>Repair: Deactivate the ground level shutdown switch.</p> <p>Result: The ground level shutdown switch has not been activated.</p> <p>Proceed to Test Step 2.</p>
<p>2. Diagnostic Codes</p> <p>A. Connect the electronic service tool to the diagnostic connector.</p> <p>B. Crank the engine for 30 seconds.</p> <p>C. Turn the keyswitch to the ON position.</p> <p>D. Use the electronic service tool to check for active diagnostic codes.</p>	<p>Diagnostic codes</p>	<p>Result: There are active diagnostic codes.</p> <p>Repair: Troubleshoot all active diagnostic codes before continuing with this procedure. Refer to Troubleshooting, "Diagnostic Trouble Codes".</p> <p>Result: There are no active diagnostic codes.</p> <p>Proceed to Test Step 3.</p>
<p>3. Visible Faults</p> <p>A. Visually inspect the engine for the following faults:</p> <ul style="list-style-type: none"> ·Missing components ·Damaged components ·Damaged electrical cables or loose electrical cables ·Oil leaks ·Fuel leaks <p>B. Check for the correct levels of fuel, oil, and coolant.</p> <p>C. If the ambient temperature is below 0 °C (32 °F), make sure that the correct specification of engine oil is used.</p> <p>D. Check that the battery voltage is correct.</p> <p>E. Use the electronic service tool to check the average cranking speed of the engine. If the cranking speed is less than 150 rpm,</p>	<p>Visible faults</p>	<p>Result: Faults found during engine inspection.</p> <p>Repair: Make any repairs, as necessary.</p> <p>Attempt to start the engine. If the engine will not start, proceed to Test Step 4.</p> <p>Result: No faults found.</p> <p>Proceed to Test Step 4.</p>

<p>investigate the cause of the low cranking speed.</p> <p>F. Make sure that all fuel filters are correctly installed.</p> <p>G. Drain any water from the primary fuel filter/water separator.</p>		
<p>4. Air Intake and Exhaust System</p> <p>A. Check the air filter restriction indicator.</p> <p>B. Ensure that the air filter is clean and serviceable</p> <p>C. Check the air intake and exhaust systems for the following defects:</p> <ul style="list-style-type: none"> · Blockages · Restrictions · Damage to lines or hoses 	<p>Defects</p>	<p>Result: A defect was found in the air intake or exhaust system.</p> <p>Repair: Make any necessary repairs. Attempt to start the engine. If the engine will not start, proceed to Test Step 5.</p> <p>Result: No defects found in the air intake or exhaust systems.</p> <p>Proceed to Test Step 5.</p>
<p>5. Fuel System Inspection</p> <p>A. Check that the fuel shut-off valve is in the OPEN position.</p> <p>B. If the temperature is below 0 °C (32 °F), check for solidified fuel (wax).</p> <p>C. Check for fuel supply lines that are restricted.</p> <p>D. Check that the low-pressure fuel lines are correctly installed.</p> <p>E. Check the pressures in the fuel system. Refer to Systems Operation, Testing, and Adjusting, "Fuel System Pressure - Test"</p> <p>F. Check the diesel fuel for contamination. Refer to Systems Operation, Testing, and Adjusting, "Fuel Quality - Test".</p> <p>G. Check for air in the fuel system. Refer to Systems Operation, Testing, and Adjusting, "Air in Fuel - Test".</p>	<p>Fuel System</p>	<p>Result: A defect was found in the fuel system.</p> <p>Repair: Make any necessary repairs. Attempt to start the engine. If the engine will not start, proceed to Test Step 6.</p> <p>Result: No defects found.</p> <p>Proceed to Test Step 6.</p>

<p>H. Ensure that the fuel system has been primed. Refer to Systems Operation, Testing, and Adjusting, "Fuel System - Prime".</p>		
<p>6. Fuel Filters</p> <p>A. Replace the primary fuel filter and the secondary fuel filter. Refer to the Operation and Maintenance Manual, "Fuel System Primary Filter (Water Separator) Element - Replace".</p> <p>B. Attempt to start the engine.</p>	<p>Engine start</p>	<p>Result: The engine starts.</p> <p>Return the engine to service.</p> <p>Result: The engine does not start.</p> <p>Proceed to Test Step 7.</p>

CAT C3.4B Engine Parts

Contact phone: 269 673 1638

Email: EngineParts@HeavyEquipmentRestorationParts.com

Alternate email: engineparts2@gmail.com

Website: www.CATC34B.com

Related website: www.HeavyEquipmentRestorationParts.com

www.FPTIndustrialEngineParts.com

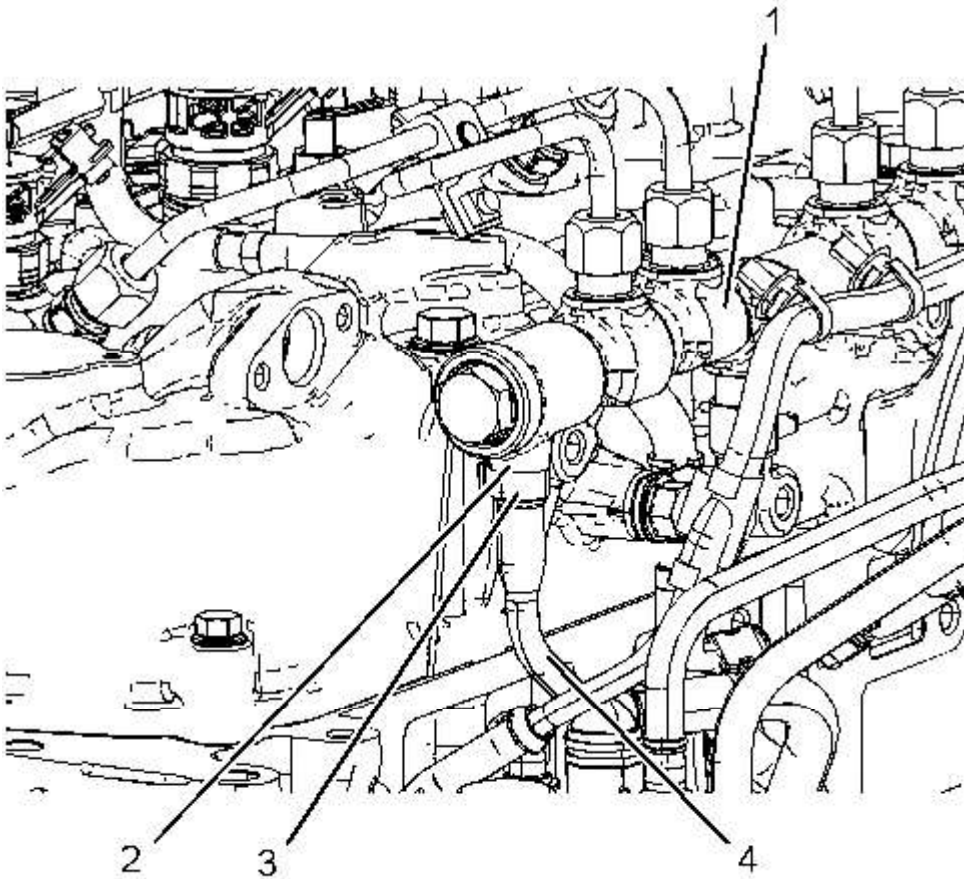

Illustration 1

g03705140

View of the fuel manifold (typical example)

Table 2

Troubleshooting Test Steps	Values	Results
<p>7. Fuel Rail Pressure Relief Valve (PRV)</p> <p>A. Turn the keyswitch to the OFF position.</p> <p>B. Disconnect plastic tube assembly (4) from fuel manifold (1). Refer to Disassembly and Assembly, "Fuel Manifold (Rail) - Remove and Install".</p> <p>C. Securely seal the end of plastic tube assembly (4). Note: Plastic tube assembly (4) must be sealed to prevent air ingress into the fuel system.</p> <p>D. Attach a length of hose to fuel</p>	<p>Fuel in container</p>	<p>Result: Fuel is present in the container.</p> <p>Repair: Install a replacement fuel manifold. Refer to Disassembly and Assembly, "Fuel Manifold (Rail) - Remove and Install". When the fuel manifold has been replaced, use the electronic service tool to perform the "Rail Pressure Sensor Replacement Reset".</p> <p>Result: No fuel is present in the container.</p> <p>Proceed to Test Step 8.</p>

<p>manifold (1) and secure with a clip at position (3).</p> <p>E. Place the other end of the hose into a container that is suitable for fuel. Ensure that the hose is secure and will not come out of the container while the engine is running.</p> <p>F. Turn the keyswitch to the ON position.</p> <p>G. Crank the engine for a maximum of 30 seconds.</p> <p>H. After the engine has stopped, check the container for fuel.</p>		
<p>8. Fuel Pump Timing</p> <p>A. Check the timing of the high-pressure fuel pump. Refer to Systems Operation, Testing, and Adjusting, "Fuel Injection Timing - Check".</p>	<p>Fuel pump timing</p>	<p>Result: The fuel pump timing is incorrect.</p> <p>Repair: Make any necessary adjustments. Attempt to start the engine. If the engine will not start, proceed to Test Step 9.</p> <p>Result: The fuel pump timing is OK.</p> <p>Proceed to Test Step 9.</p>
<p>9. Low Compression (Cylinder Pressure)</p> <p>A. Perform a compression test. Refer to Systems Operation, Testing, and Adjusting, "Compression - Test".</p>	<p>Low compression</p>	<p>Result: Low compression is recorded on one or more cylinders.</p> <p>Possible causes of low compression are shown in the following list:</p> <ul style="list-style-type: none"> •Loose glow plugs •Faulty piston •Faulty piston rings •Worn cylinder bores •Worn valves •Faulty cylinder head gasket •Damaged cylinder head <p>Repair: Make any repairs, as necessary. Attempt to start the engine. If the engine will not start, contact the Dealer Solution Network (DSN).</p> <p>Result: No faults found.</p>

		Contact the Dealer Solutions Network (DSN).
--	--	---



Previous Screen



Troubleshooting
C3.4B Engines

Media Number -UENR0611-10

Publication Date -01/02/2015

i06223545

Engine Does Not Crank

SMCS - 1000-035; 1450-035

Probable Causes

- Battery cables and batteries
- Switches and/or circuit breakers
- Safety interlock on the application
- Starting motor solenoid or starting circuit
- Starting motor and/or flywheel ring gear
- Engine accessories and transmission
- Hydraulic lock

Recommended Repairs

Complete the procedure in the order in which the steps are listed.

Table 1

Troubleshooting Test Steps	Values	Results
<p>1. Battery Cables and Batteries</p> <p>A. Inspect the main power switch, battery posts, and battery cables for loose connections and for corrosion. If the battery cables are corroded, remove the battery cables and clean the battery cables. Tighten any loose connections.</p>	<p>Batteries and cables</p>	<p>Result: The batteries and cables are not OK.</p> <p>Repair: Make the necessary repairs.</p> <p>Result: The batteries and cables are OK.</p>

<p>B. Inspect the batteries.</p> <p>C. Charge the batteries.</p> <p>Test the batteries. Refer to Systems Operation, Testing and Adjusting, "Battery - Test ".</p>		<p>Proceed to Test Step 2.</p>
<p>2. Switches and/or Circuit Breakers</p> <p>A. Check any switches and/or circuit breakers that may interfere with the engine cranking. Refer to the applications electrical schematic for additional information.</p>	<p>Switches and/or circuit breakers</p>	<p>Result: The switches and/or circuit breakers are not OK.</p> <p>Repair: Make the necessary repairs.</p> <p>Result: The switches and/or circuit breakers are OK.</p> <p>Proceed to Test Step 3.</p>
<p>3. Safety Interlock on the Application</p> <p>A. Check that any safety interlock features on the application are in the safe position. Refer to the OEM documentation for details of any safety interlocks on the application.</p>	<p>Safety interlocks</p>	<p>Result: A safety interlock is preventing the engine from starting.</p> <p>Repair: Disengage the safety interlock if it is safe to do so. If necessary, repair the safety interlock.</p> <p>Result: There are no safety interlocks preventing the engine from starting.</p> <p>Proceed to Test Step 4.</p>
<p>4. Starting Motor Solenoid and Starting Circuit</p> <p>A. Test the operation of the starting motor circuit. Refer to Systems Operation/Testing and Adjusting, "Electric Starting System - Test".</p>	<p>Starting motor solenoid and circuit</p>	<p>Result: The starting motor solenoid and circuit are not OK.</p> <p>Repair: Make the necessary repairs.</p> <p>Result: The starting motor solenoid and circuit are OK.</p>

		Proceed to Test Step 5.
<p>5. Starting Motor and/or Flywheel Ring Gear</p> <p>A. Test the operation of the starting motor.</p> <p>B. Check the wiring for the starting motor. Refer to Systems Operation, Testing, and Adjusting, "Electric Starting System - Test".</p> <p>C. Check the pinion clearance. Inspect the pinion and the flywheel ring gear for damage. Refer to Systems Operation/Testing and Adjusting, "Electrical System" for additional information.</p>	Starter pinion and flywheel ring gear are OK	<p>Result: The starter pinion and flywheel ring gear are not OK.</p> <p>Repair: Make the necessary repairs.</p> <p>Result: The starting motor and flywheel ring gear are OK.</p> <p>Proceed to Test Step 6.</p>
<p>6. Engine Accessories and Transmission</p> <p>A. Ensure free movement of the driveline.</p> <p>B. Remove and inspect any engine accessories that may lock up the engine.</p> <p>The following list contains examples of engine accessories that may lock up the engine:</p> <ul style="list-style-type: none"> · Hydraulic pump that is driven from the rear gear group · Air compressor · Engine oil pump · Other components that are driven by the engine 	Engine accessories and transmission	<p>Result: The engine accessories and transmission are not OK.</p> <p>Repair: Make the necessary repairs.</p> <p>Result: The engine accessories and transmission are OK.</p> <p>Proceed to Test Step 7.</p>
<p>7. Hydraulic Lock</p> <p>Note: If an injector has been replaced, evacuate any fluids from the cylinder and attempt to start the engine. Fuel will flow from the cylinder head into the cylinders when a unit injector is removed.</p> <p>A. Check for fluid in the cylinders by removing the individual unit injectors. Check for damaged seals.</p> <p>B. If there was excessive fuel in the cylinder, replace the seals and reinstall the injector. Drain any excess fuel from the cylinder head.</p>	Hydraulic lock	<p>Result: The engine has a hydraulic lock.</p> <p>Repair: Make the necessary repairs.</p> <p>Result: The engine rotates freely.</p> <p>Contact the Dealer Solution Network (DSN).</p>

<p>C. If a mechanical problem is suspected, disassemble the engine. Refer to the Disassembly and Assembly manual. Inspect the internal components for the following conditions:</p> <ul style="list-style-type: none">· Seizure· Broken components· Bent components		
---	--	--

CAT C3.4B Engine Parts

Contact phone: 269 673 1638

Email: EngineParts@HeavyEquipmentRestorationParts.com

Alternate email: engineparts2@gmail.com

Website: www.CATC34B.com

Related website: www.HeavyEquipmentRestorationParts.com

www.FPTIndustrialEngineParts.com



Previous Screen



Troubleshooting
C3.4B Engines

Media Number -UENR0611-10

Publication Date -01/02/2015

i06223552

Engine Has Early Wear

SMCS - 1000-035; 1200-035

Probable Causes

- Contaminated oil
- Leaks in air intake system
- Engine History
- Low oil pressure
- Dirt in engine oil
- Incorrect oil
- Dirt in fuel

Recommended Actions

Note: The procedures have been listed in order of probability. Complete the procedures in order.

Table 1

Troubleshooting Test Steps	Values	Results
<p>1. Contaminated Oil</p> <p>A. Check an oil sample for contamination with fuel. Refer to Troubleshooting, "Oil Contains Fuel".</p>	<p>Oil contains fuel</p>	<p>Result: The engine oil is contaminated with fuel.</p> <p>Repair: Investigate the cause. Refer to Troubleshooting, "Oil Contains Fuel".</p> <p>Result: The engine oil is not</p>

		contaminated with fuel. Proceed to Test Step 2.
<p>2. Leaks in Air Intake System</p> <p>A leak in the air intake system may allow unfiltered air into the engine.</p> <p>A. Inspect the air intake system for streaks which may indicate a leakage of unfiltered air. Inspect all of the gaskets and the connections. Refer to Systems Operation, Testing, and Adjusting, "Air Inlet and Exhaust System".</p>	Leaks in Air Intake System	<p>Result: Leaks found in air intake system.</p> <p>Repair: Repair any leaks.</p> <p>Result: The air intake system is OK.</p> <p>Proceed to Test Step 3.</p>
<p>3. Engine History</p> <p>A. Check that the engine has been serviced to the correct maintenance intervals. Refer to Operation and Maintenance Manual, "Maintenance Interval Schedule"</p> <p>B. Check the engine history for frequent starting and stopping in cold conditions.</p> <p>Note: Frequent starting and stopping of the engine can cause early wear. Also, operation of the engine for short periods of time in cold conditions can cause early wear.</p>	Maintenance intervals	<p>Result: The engine is not correctly maintained.</p> <p>Repair: Make sure that the engine is maintained at the correct maintenance intervals. Refer to the Operation and Maintenance Manual, "Maintenance Interval Schedule".</p> <p>Result: The engine is correctly maintained.</p> <p>Proceed to Test Step 4.</p>
<p>4. Low Oil Pressure</p> <p>A. Check for frequently logged diagnostic codes relating to low oil pressure.</p>	Low oil pressure	<p>Result: The engine has a history of low oil pressure.</p> <p>Repair: Refer to Troubleshooting, "Oil Pressure Is Low".</p> <p>Result: There are no logged diagnostic codes for low oil pressure.</p> <p>Proceed to Test Step 5.</p>

<p>5. Dirt in Engine Oil</p> <p>A. Check the engine oil for dirt or debris.</p>	<p>Dirt in engine oil</p>	<p>Result: The engine oil shows signs of dirt or debris</p> <p>Repair: Drain the oil from the crankcase and refill the crankcase with clean engine oil. Install new engine oil filters. Refer to the Operation and Maintenance Manual for more information.</p> <p>Result: The engine oil is clean.</p> <p>Proceed to Test Step 6.</p>
<p>6. Incorrect Oil</p> <p>A. Check that the engine is filled with oil of the correct specification. Refer to the Operation and Maintenance Manual, "Refill Capacities and Recommendations".</p>	<p>Oil specification</p>	<p>Result: The oil specification is incorrect.</p> <p>Repair: Drain the engine oil system and refill the engine oil system. Refer to Operation and Maintenance Manual, "Engine Oil and Filter - Change".</p> <p>Result: The oil specification is correct.</p> <p>Proceed to Test Step 7.</p>
<p>7. Dirt in Fuel</p> <p>A. Remove the fuel filters. Inspect the fuel filters for contamination.</p> <p>Note: Contaminants in the fuel such as hydrogen sulfide and sulfur can lead to the formation of acids in the crankcase.</p> <p>B. Obtain a fuel analysis.</p>	<p>Fuel and fuel filters</p>	<p>Result: The fuel has contamination.</p> <p>Repair: Determine the cause of any contamination and make the necessary repairs.</p> <p>Install new fuel filters. Refer to the Operation and Maintenance Manual.</p> <p>Result: The fuel is not contaminated.</p> <p>Contact the Dealer Solution Network (DSN).</p>

[Previous Screen](#)

Troubleshooting

C3.4B Engines

Media Number -UENR0611-10

Publication Date -01/02/2015

i06704802

Engine Has Mechanical Noise (Knock)

SMCS - 1000-035

Probable Causes

- Diagnostic codes
- Electrical connections
- Fuel quality
- Correct lubrication
- Engine accessories
- Valve train components
- Gear train and lower end components
- Crankshaft

Recommended Actions

Note: The procedures have been listed in order of probability. Complete the procedures in order.

Table 1

Troubleshooting Test Steps	Values	Results
<p>1. Diagnostic Codes</p> <p>A. Establish communication between the electronic service tool and the Electronic Control Module (ECM). Refer to Troubleshooting, "Electronic Service Tools",</p>	Diagnostic codes	<p>Result: There are active codes.</p> <p>Repair: Troubleshoot any active codes before continuing with this procedure.</p>

<p>if necessary.</p>		<p>Result: There are no active codes.</p> <p>Proceed to Test Step 2.</p>
<p>2. Electrical Connections</p> <p>A. Check for the correct installation of the ECM P1 and P2 connectors. Check for correct installation of the fuel injector connectors.</p>	<p>Connectors</p>	<p>Result: There are suspect connectors.</p> <p>Repair: Repair connectors that are suspect or replace connectors that are suspect.</p> <p>Perform the "Wiggle Test" on the electronic service tool</p> <p>Result: There are no suspect connectors.</p> <p>Proceed to Test Step 3.</p>
<p>3. Fuel Quality</p> <p>A. Obtain a fuel analysis to confirm that the correct fuel is being used for the engine. Refer to Systems Operation/Testing and Adjusting, "Fuel System Quality Test" for the proper procedure.</p>	<p>Fuel</p>	<p>Result: The fuel quality is not OK.</p> <p>Note: Refer to Operation and Maintenance Manual for information on the proper characteristics of the fuel for the engine. If necessary,</p> <p>Repair: Replace the fuel. Verify that the repair eliminated the noise.</p> <p>Result: The fuel quality is OK.</p> <p>Proceed to Test Step 4.</p>
<p>4. Correct Lubrication</p> <p>A. Check for correct lubrication of the valve components. Check for sufficient lubrication between the injector tappets and the rocker arms.</p> <p>B. Check for blocked oil passages. Oil passages must be clean. Clean any oil passages that are questionable. Refer to the Disassembly and Assembly for additional</p>	<p>Lubrication</p>	<p>Result: The oil passages are blocked or the engine does not have correct lubrication.</p> <p>Repair: Make the necessary repairs, Verify that the repair eliminated the noise.</p> <p>Result: The oil passages are not blocked and the engine has proper lubrication.</p>

<p>information.</p> <p>C. Inspect the engine oil filters for ferrous material.</p> <p>D. Obtain an oil analysis. The analysis will contribute to a better understanding of oil contamination and the origin of the contamination.</p>		<p>Proceed to Test Step 5.</p>
<p>5. Engine Accessories</p> <p>A. Attempt to isolate the source of the noise.</p>	<p>Engine accessory</p>	<p>Result An engine accessory is the source of the noise.</p> <p>Repair: Repair the engine accessory and/or replace the engine accessory, as necessary.</p> <p>Result An engine accessory is not the source of the noise.</p> <p>Proceed to Test Step 6.</p>
<p>6. Valve Train Components</p> <p>A. Check the valve lash. Refer to Systems Operation, Testing, and Adjusting, "Valve Lash - Inspect/Adjust".</p> <p>B. Check for damage to valve train components. Remove the valve cover. Check the following items for damage:</p> <ul style="list-style-type: none"> · Camshaft · Valve springs · Camshaft followers · Rocker shaft · Pushrods <p>Refer to the Disassembly and Assembly for additional information.</p> <p>C. Check for valves that do not move freely. If necessary, remove the cylinder head and inspect the valves. Refer to the Disassembly and Assembly for</p>	<p>Valve train</p>	<p>Result: The valve train components are damaged.</p> <p>Repair: Make the necessary repairs, Verify that the repair eliminated the noise.</p> <p>Result: The valve train components are not damaged.</p> <p>Proceed to Test Step 7.</p>

additional information.		
<p>7. Gear Train and Components of the Lower End</p> <p>A. Inspect the gear train and lower end components.</p>	Gear train	<p>Result: The gear train or lower end components are damaged.</p> <p>Repair: Replace any damaged parts.</p> <p>Result: The gear train or lower end components are not damaged.</p> <p>Proceed to Test Step 8.</p>
<p>8. Crankshaft</p> <p>A. Inspect the crankshaft and the related components. Look for worn thrust plates and wear on the crankshaft.</p> <p>B. Inspect the connecting rod bearings and the bearing surfaces on the crankshaft. Make sure that the bearings are in the correct position.</p>	Crankshaft	<p>Result: The crankshaft or the related components are damaged or worn.</p> <p>Repair: Repair or replace any damaged parts. Verify that the repair eliminated the noise.</p> <p>Result: The crankshaft or the related components are not damaged or worn.</p> <p>Contact the Dealer Solution Network (DSN).</p>

CAT C3.4B Engine Parts
Contact phone: 269 673 1638
Email: EngineParts@HeavyEquipmentRestorationParts.com
Alternate email: engineparts2@gmail.com
Website: www.CATC34B.com
Related website: www.HeavyEquipmentRestorationParts.com
www.FPTIndustrialEngineParts.com



Previous Screen



Troubleshooting
C3.4B Engines

Media Number -UENR0611-10

Publication Date -01/02/2015

i06224976

Engine Misfires, Runs Rough or Is Unstable

SMCS - 1000-035

Note: If the fault is intermittent and the fault cannot be duplicated, refer to Troubleshooting, "Power Is Intermittently Low or Power Cutout Is Intermittent".

Note: If the fault only occurs under certain conditions, test the engine under those conditions. Examples of certain conditions are high rpm, full load, and engine operating temperature. Troubleshooting the symptoms under other conditions can give misleading results.

Probable Causes

- Diagnostic codes
- Air Intake and Exhaust System
- Fuel System Inspection
- Throttle Position Sensor/Throttle Switches
- High-pressure fuel pump
- Low compression (cylinder pressure)
- Electronic unit injectors
- Individual malfunctioning cylinder

Recommended Actions

Note: The procedures have been listed in order of probability. Complete the procedures in order.

Table 1

Troubleshooting Test Steps	Values	Results

<p>1. Diagnostic Codes</p> <p>A. Establish communication between the electronic service tool and the Electronic Control Module (ECM). Refer to Troubleshooting, "Electronic Service Tools", if necessary.</p>	<p>Diagnostic codes</p>	<p>Result: There are active codes.</p> <p>Repair: Troubleshoot any active codes before continuing with this procedure.</p> <p>Result: There are no active codes.</p> <p>Proceed to Test Step 2.</p>
<p>2. Air Intake and Exhaust System</p> <p>A. Check the air filter restriction indicator.</p> <p>B. Ensure that the air filter is clean and serviceable</p> <p>C. Check the air intake and exhaust systems for the following defects:</p> <ul style="list-style-type: none"> · Blockages · Restrictions · Damage to lines or hoses 	<p>Fuel System</p>	<p>Result: A defect was found in the air intake or exhaust system.</p> <p>Repair: Make any necessary repairs.</p> <p>Result: No defects found in the air intake or exhaust systems.</p> <p>Proceed to Test Step 3.</p>
<p>3. Fuel System Inspection</p> <p>A. Check that the fuel shut-off valve is in the OPEN position.</p> <p>B. If the temperature is below 0 °C (32 °F), check for solidified fuel (wax).</p> <p>C. Check for fuel supply lines that are restricted.</p> <p>D. Check that the low-pressure fuel lines are correctly installed.</p> <p>E. Check the pressures in the fuel system. Refer to Systems Operation, Testing, and Adjusting, "Fuel System Pressure - Test"</p> <p>F. Check the diesel fuel for contamination. Refer to Systems Operation, Testing, and Adjusting, "Fuel Quality - Test".</p> <p>G. Check for air in the fuel system. Refer to</p>	<p>Fuel supply</p>	<p>Result: A defect was found in the fuel system.</p> <p>Repair: Make any necessary repairs.</p> <p>Result: No defects found.</p> <p>Proceed to Test Step 4.</p>

<p>Systems Operation, Testing, and Adjusting, "Air in Fuel - Test".</p> <p>H. Ensure that the fuel system has been primed. Refer to Systems Operation, Testing, and Adjusting, "Fuel System - Prime".</p>		
<p>4. Throttle Position Sensor/Throttle Switches (if equipped)</p> <p>A. Turn the start switch to the ON position.</p> <p>B. Run the engine until the speed is equal to the maximum no-load speed.</p> <p>C. Use the electronic service tool to make sure that the throttle is set to reach the maximum no-load speed.</p>	<p>Electrical connections</p>	<p>Result: The throttle response is not as expected.</p> <p>Repair: If the maximum no-load speed cannot be obtained refer to Troubleshooting, "Switch Circuits - Test (Throttle Switch)" and Troubleshooting, "Mode Selection - Test".</p> <p>If the engine speed is erratic refer to Troubleshooting, "Speed Control - Test".</p> <p>Result: All responses are normal.</p> <p>Proceed to Test Step 5.</p>
<p>5. High-Pressure Fuel Pump</p> <p>Note: The fuel injection pump that is installed by the factory is a non-serviceable item. If any fault occurs within the fuel injection pump, the fuel injection pump must be replaced.</p> <p>A. Use the electronic service tool to select the correct screen in order to display any diagnostic trouble codes that relate to the fuel injection pump.</p>	<p>HP fuel pump</p>	<p>Result: There are diagnostic codes associated with the high-pressure fuel pump.</p> <p>Repair: Diagnose the codes. Refer to Troubleshooting, "Diagnostic Trouble Codes".</p> <p>If necessary, replace the high-pressure fuel pump.</p> <p>Result: The high-pressure fuel pump is OK.</p> <p>Proceed to Test Step 6.</p>
<p>6. Low Compression (Cylinder Pressure)</p> <p>A. Perform a compression test. Refer to Systems Operation, Testing, and Adjusting,</p>	<p>Cylinder compression</p>	<p>Result: The results of the compression test are outside the specifications.</p> <p>Repair: Investigate the cause</p>

<p>"Compression - Test ".</p>		<p>and rectify any faults.</p> <p>Note: Possible causes of low compression are shown in the following list:</p> <ul style="list-style-type: none"> · Loose glow plugs · Faulty piston · Faulty piston rings · Worn cylinder bores · Worn valves · Faulty cylinder head gasket · Damaged cylinder head <p>Result: The results of the compression test are OK.</p> <p>Proceed to Test Step 7.</p>
<p>7. Electronic Unit Injectors</p> <p>A. Use the electronic service tool to check for active diagnostic codes that relate to the electronic unit injectors.</p>	<p>Diagnostic codes</p>	<p>Result: There are active diagnostic codes relating to the fuel injectors.</p> <p>Repair: Troubleshoot any active diagnostic codes associated with the fuel injectors. Refer to Troubleshooting, "Diagnostic Trouble Codes"</p> <p>Result: All injectors are OK.</p> <p>Proceed to Test Step 8.</p>
<p>8. Individual Malfunctioning Cylinders</p> <p>A. With the engine speed at a fast idle, use the electronic service tool to perform the manual "Cylinder Cut Out Test". As each cylinder is cut out, listen for a change in the sound from the engine. When a cylinder is cut out, there should be a noticeable change in the sound of the engine.</p>	<p>Cylinders</p>	<p>Result: There is not a noticeable change in the sound of the engine for at least one cylinder.</p> <p>Repair: Investigate the cause of the fault on any cylinder that is not operating. Investigate the cause of the fault on any cylinder that is operating below normal performance.</p> <p>Result: There is a noticeable change in the sound of the engine for each cylinder.</p>

	Contact the Dealer Solution Network (DSN).
--	---

CAT C3.4B Engine Parts

Contact phone: 269 673 1638

Email: EngineParts@HeavyEquipmentRestorationParts.com

Alternate email: engineparts2@gmail.com

Website: www.CATC34B.com

Related website: www.HeavyEquipmentRestorationParts.com

www.FPTIndustrialEngineParts.com



Troubleshooting

C3.4B Engines

Media Number -UENR0611-10

Publication Date -01/02/2015

i05980574

Engine Monitoring System

SMCS - 1900

The Electronic Control Module (ECM) provides a comprehensive engine monitoring system for this engine. The ECM monitors specific engine operating parameters in order to detect abnormal conditions that may develop. The ECM will generate a diagnostic code if a specific engine parameter exceeds an acceptable range that is defined by the engine monitoring system. The ECM will react with an action that is dependent on the severity of the condition. For information on diagnostic codes, refer to Troubleshooting, "Diagnostic Trouble Codes".

The following actions may be initiated by the ECM. These actions are dependent on the severity of the condition.

- Illumination of a warning lamp or warning alarm
- Engine derate
- Engine shutdown

Use the electronic service tool to perform the following activities for the monitoring system:

- Viewing parameters
- Parameter programming
- Set delay times

The default settings for the parameters are programmed at the factory. To accommodate unique applications and sites, some of the parameters may be reprogrammed with the electronic service tool. Use the electronic service tool to modify the monitoring system parameters.

Note: Some parameters cannot be changed. Some applications do not allow any changes to the programmable monitoring system.



Previous Screen



Troubleshooting
C3.4B Engines

Media Number -UENR0611-10

Publication Date -01/02/2015

i06224985

Engine Overspeeds

SMCS - 1915-035

This procedure covers the following diagnostic code:

Table 1

Diagnostic Trouble Codes for the Engine Pressure Sensors		
J1939 Code	Description	Notes
190-15	Engine Speed : High - least severe (1)	The Electronic Control Module (ECM) detects that the engine speed has exceeded 3100 rpm for at least 5 seconds. If equipped, the warning lamp will flash.

The Electronic Control Module (ECM) limits the flow of fuel in order to prevent the engine speed from exceeding the maximum rpm. When the engine speed has dropped to less than the maximum rpm, the engine overspeed diagnostic code will be reset.

The following operating conditions can cause the engine speed to exceed this value:

- On a mobile machine, an incorrect transmission gear is selected.
- Use of an incorrect fuel
- Combustible gases in the air inlet for the engine

If the engine speed exceeds the maximum rpm, the ECM illuminates the warning lamp and an engine overspeed diagnostic code is logged. No troubleshooting is required.

The history of engine overspeeds can be viewed on the electronic service tool.



Previous Screen



Troubleshooting
C3.4B Engines

Media Number -UENR0611-10

Publication Date -01/02/2015

i06224988

Engine Shutdown Occurs Intermittently

SMCS - 1900-035

Note: Use this procedure only if the engine shuts down completely and the engine must be restarted.

Probable Causes

- Diagnostic codes
- Air Intake
- Electrical connectors
- Fuel supply
- Switches

Recommended Actions

Note: The procedures have been listed in order of probability. Complete the procedures in order.

Table 1

Troubleshooting Test Steps	Values	Results
<p>1. Diagnostic Codes</p> <p>Note: Certain diagnostic codes and/or event codes may cause an engine shutdown.</p> <p>A. Connect the electronic service tool and check for active codes and for</p>	Codes	<p>Result: There are active codes.</p> <p>Repair: Troubleshoot any active codes before continuing with this procedure. Refer to Troubleshooting, "Diagnostic Trouble Codes"</p> <p>Result: There are no active codes.</p>

logged codes.		Proceed to Test Step 2.
<p>2. Air Intake</p> <p>A. Check the air filter for blockages or restrictions.</p> <p>B. Check the air intake duct for blockages or restrictions.</p>	Blockages or restrictions	<p>Result: Blockages or restrictions found.</p> <p>Repair: Make any repairs, as necessary.</p> <p>Result: The air intake system is OK.</p> <p>Proceed to Test Step 3.</p>
<p>3. Electrical Connectors</p> <p>A. Check for the correct installation of the ECM J1/P1 and the J2/P2 connectors. Check for correct installation of the fuel injector connectors.</p>	Connectors	<p>Result: There are suspect connectors.</p> <p>Repair: Repair connectors that are suspect or replace connectors that are suspect.</p> <p>Result: There are no suspect connectors.</p> <p>Proceed to Test Step 4.</p>
<p>4. Fuel System Inspection</p> <p>A. Check that the fuel shut-off valve is in the OPEN position.</p> <p>B. If the temperature is below 0 °C (32 °F), check for solidified fuel (wax).</p> <p>C. Check for fuel supply lines that are restricted.</p> <p>D. Check that the low-pressure fuel lines are correctly installed.</p> <p>E. Check the pressures in the fuel system. Refer to Systems Operation, Testing, and Adjusting, "Fuel System Pressure - Test"</p> <p>F. Check the diesel fuel for contamination. Refer to Systems Operation, Testing, and Adjusting, "Fuel Quality - Test".</p> <p>G. Check for air in the fuel system.</p>	Fuel System	<p>Result: A defect was found in the fuel system.</p> <p>Repair: Make any necessary repairs.</p> <p>Result: No defects found.</p> <p>Proceed to Test Step 5.</p>

<p>Refer to Systems Operation, Testing, and Adjusting, "Air in Fuel - Test".</p> <p>H. Ensure that the fuel system has been primed. Refer to Systems Operation, Testing, and Adjusting, "Fuel System - Prime".</p>		
<p>5. Switches</p> <p>A. Check the keyswitch input to the ECM.</p> <p>B. Check any engine shutdown switches and associated wiring.</p>	<p>Switches</p>	<p>Result: The shutdown switches and wiring are not OK.</p> <p>Repair: Make the necessary repairs, Verify that the repair eliminated the fault.</p> <p>Result: The shutdown switches and wiring are OK.</p> <p>Contact the Dealer Solution Network (DSN).</p>

CAT C3.4B Engine Parts
Contact phone: 269 673 1638
Email: EngineParts@HeavyEquipmentRestorationParts.com
Alternate email: engineparts2@gmail.com
Website: www.CATC34B.com
Related website: www.HeavyEquipmentRestorationParts.com
www.FPTIndustrialEngineParts.com



Previous Screen



Troubleshooting
C3.4B Engines

Media Number -UENR0611-10

Publication Date -01/02/2015

i06225009

Engine Stalls at Low RPM

SMCS - 1000-035; 1900-035

Probable Causes

- Diagnostic codes
- Accessory equipment
- Fuel system inspection
- Low compression (cylinder pressure)
- Electronic unit injectors

Recommended Actions

Note: The procedures have been listed in order of probability. Complete the procedures in order.

Table 1

Troubleshooting Test Steps	Values	Results
<p>1. Diagnostic Codes</p> <p>A. Establish communication between the electronic service tool and the Electronic Control Module (ECM) . Refer to Troubleshooting, "Electronic Service Tools", if necessary.</p> <p>B. Check if any codes are active or logged.</p>	<p>Diagnostic code</p>	<p>Result: A code is active or logged.</p> <p>Repair: Troubleshoot any codes before continuing with this procedure.</p> <p>Result: A code is not active or logged.</p> <p>Proceed to Test Step 2.</p>

<p>2. Accessory Equipment</p> <p>A. Check all accessory equipment for faults that may create excessive load on the engine.</p>	<p>Accessories</p>	<p>Result: An engine accessory is creating an excessive load.</p> <p>Repair: Repair or replace the engine accessory.</p> <p>Result: An engine accessory is not creating an excessive load.</p> <p>Proceed to Test Step 3.</p>
<p>3. Fuel System Inspection</p> <p>A. Check that the fuel shut-off valve is in the OPEN position.</p> <p>B. If the temperature is below 0 °C (32 °F), check for solidified fuel (wax).</p> <p>C. Check for fuel supply lines that are restricted.</p> <p>D. Check that the low-pressure fuel lines are correctly installed.</p> <p>E. Check the pressures in the fuel system. Refer to Systems Operation, Testing, and Adjusting, "Fuel System Pressure - Test"</p> <p>F. Check the diesel fuel for contamination. Refer to Systems Operation, Testing, and Adjusting, "Fuel Quality - Test".</p> <p>G. Check for air in the fuel system. Refer to Systems Operation, Testing, and Adjusting, "Air in Fuel - Test".</p> <p>H. Ensure that the fuel system has been primed. Refer to Systems Operation, Testing, and Adjusting, "Fuel System - Prime".</p>	<p>Fuel System</p>	<p>Result: A defect was found in the fuel system.</p> <p>Repair: Make any necessary repairs.</p> <p>Result: No defects found.</p> <p>Proceed to Test Step 4.</p>
<p>4. Low Compression (Cylinder Pressure)</p> <p>A. Perform a compression test. Refer to Systems Operation, Testing, and Adjusting, "Compression - Test".</p>	<p>Low compression</p>	<p>Result: Low compression is recorded on one or more cylinders.</p> <p>Repair: Possible causes of low compression are shown in the following list:</p>

		<ul style="list-style-type: none"> ·Loose glow plugs ·Faulty piston ·Faulty piston rings ·Worn cylinder bores ·Worn valves ·Faulty cylinder head gasket ·Damaged cylinder head <p>Make any repairs, as necessary.</p> <p>Result: No faults found.</p> <p>Proceed to Test Step 5.</p>
<p>5. Electronic Unit Injectors</p> <p>A. Use the electronic service tool to check for active diagnostic codes that relate to the fuel injectors.</p>	<p>Diagnostic codes</p>	<p>Result: There are active diagnostic codes for the fuel injectors</p> <p>Repair: Troubleshoot the active diagnostic codes. Refer to Troubleshooting, "Diagnostic Trouble Codes"</p> <p>Result: All injectors are OK.</p> <p>Contact the Dealer Solution Network (DSN).</p>

CAT C3.4B Engine Parts
Contact phone: 269 673 1638
Email: EngineParts@HeavyEquipmentRestorationParts.com
Alternate email: engineparts2@gmail.com
Website: www.CATC34B.com
Related website: www.HeavyEquipmentRestorationParts.com

www.FPTIndustrialEngineParts.com



Previous Screen



Troubleshooting
C3.4B Engines

Media Number -UENR0611-10

Publication Date -01/02/2015

i06225011

Engine Top Speed Is Not Obtained

SMCS - 1915-035

Note: If this fault occurs only under load, refer to Troubleshooting, "Acceleration Is Poor or Throttle Response Is Poor".

Probable Causes

- Diagnostic codes
- Engine accessories and transmission
- ECM parameters
- Throttle signal from the throttle position sensor
- Air intake and exhaust system
- Fuel system inspection
- Fuel filters
- Low compression (cylinder pressure)
- Individual malfunctioning cylinders

Recommended Actions

Note: The procedures have been listed in order of probability. Complete the procedures in order.

Table 1

Troubleshooting Test Steps	Values	Results
1. Diagnostic Codes	Diagnostic	Result: There are active or

<p>A. Establish communication between the electronic service tool and the Electronic Control Module (ECM). Refer to Troubleshooting, "Electronic Service Tools", if necessary.</p>	<p>codes</p>	<p>logged codes.</p> <p>Repair: Troubleshoot any codes before continuing with this procedure.</p> <p>Result: There are no active or logged codes.</p> <p>Proceed to Test Step 2.</p>
<p>2. Engine Accessories and Transmission</p> <p>A. Check that the engine accessories and transmission are operating correctly.</p> <p>B. Remove and inspect any engine accessories that may be adding unexpected load to the engine.</p>	<p>Engine accessories and transmission</p>	<p>Result: The engine accessories and transmission are not OK.</p> <p>Repair: Make the necessary repairs.</p> <p>Result: The engine accessories and transmission are OK.</p> <p>Proceed to Test Step 3.</p>
<p>3. ECM Parameters</p> <p>A. Use the electronic service tool to verify that the correct engine parameters are being used. Refer to Troubleshooting, "Configuration Parameters" for additional information.</p>	<p>Parameters</p>	<p>Result: The parameters are not configured correctly.</p> <p>Repair: Correctly configure the parameters.</p> <p>Verify that the configuration change eliminated the fault.</p> <p>Result: The parameters are configured correctly.</p> <p>Proceed to Test Step 4.</p>
<p>4. Throttle Signal From the Throttle Position Sensor (if equipped)</p> <p>A. If a fault is suspected in the throttle sensor, refer to Troubleshooting, "Speed Control - Test".</p>	<p>Throttle position sensor faults</p>	<p>Result: The throttle position sensor or the associated wiring is faulty.</p> <p>Repair: Repair or replace the throttle position sensor or the associated wiring.</p> <p>Result: The throttle position sensor and the associated</p>

		<p>wiring are OK.</p> <p>Proceed to Test Step 5.</p>
<p>5. Air Intake and Exhaust System</p> <p>A. Check the air filter restriction indicator, if equipped. Clean plugged air filters or replace plugged air filters. Refer to the Operation and Maintenance Manual.</p> <p>B. Check the air inlet and exhaust system for restrictions and/or leaks. Refer to Systems Operation, Testing and Adjusting, "Air Inlet and Exhaust System - Inspect".</p>	<p>Restrictions</p>	<p>Result: The air filter is plugged.</p> <p>Repair: Clean or replace the air filter. Refer to the Operation and Maintenance Manual for further information.</p> <p>Result: There are restrictions in the air inlet or exhaust system.</p> <p>Repair: Make the necessary repairs, Verify that the repair eliminated the fault.</p> <p>Result: There are no restrictions in the air inlet or exhaust system.</p> <p>Proceed to Test Step 6.</p>
<p>6. Fuel System Inspection</p> <p>A. Check that the fuel shut-off valve is in the OPEN position.</p> <p>B. If the temperature is below 0 °C (32 °F), check for solidified fuel (wax).</p> <p>C. Check for fuel supply lines that are restricted.</p> <p>D. Check that the low-pressure fuel lines are correctly installed.</p> <p>E. Check the pressures in the fuel system. Refer to Systems Operation, Testing, and Adjusting, "Fuel System Pressure - Test"</p> <p>F. Check the diesel fuel for contamination. Refer to Systems Operation, Testing, and Adjusting, "Fuel Quality - Test".</p>	<p>Fuel System</p>	<p>Result: A defect was found in the fuel system.</p> <p>Repair: Make any necessary repairs.</p> <p>Result: No defects found.</p> <p>Proceed to Test Step 7.</p>

<p>G. Check for air in the fuel system. Refer to Systems Operation, Testing, and Adjusting, "Air in Fuel - Test".</p> <p>H. Ensure that the fuel system has been primed. Refer to Systems Operation, Testing, and Adjusting, "Fuel System - Prime".</p>		
<p>7. Fuel Filters</p> <p>A. Replace the primary fuel filter and the secondary fuel filter. Refer to the Operation and Maintenance Manual, "Fuel System Primary Filter (Water Separator) Element - Replace".</p> <p>B. Run the engine at top speed.</p>	<p>Top speed</p>	<p>Result: The engine reaches top speed.</p> <p>Return the engine to service.</p> <p>Result: The engine does not reach top speed.</p> <p>Proceed to Test Step 8.</p>
<p>8. Low Compression (Cylinder Pressure)</p> <p>A. Perform a compression test. Refer to Systems Operation, Testing, and Adjusting, "Compression - Test".</p>	<p>Low compression</p>	<p>Result: Low compression is recorded on one or more cylinders.</p> <p>Repair: Possible causes of low compression are shown in the following list:</p> <ul style="list-style-type: none"> ·Loose glow plugs ·Faulty piston ·Faulty piston rings ·Worn cylinder bores ·Worn valves ·Faulty cylinder head gasket ·Damaged cylinder head <p>Make any repairs, as necessary.</p> <p>Result: No faults found.</p> <p>Proceed to Test Step 9.</p>
<p>9. Individual Malfunctioning Cylinders</p> <p>A. With the engine speed at a fast idle, use the electronic service tool to perform the manual "Cylinder Cut Out Test". As each cylinder is cut out, listen for a change in the sound from the engine. When a cylinder is cut out, there should be a noticeable change in the</p>	<p>Cylinders</p>	<p>Result: There is not a noticeable change in the sound of the engine for at least one cylinder.</p> <p>Repair: Investigate the cause of the fault on any cylinder that is not operating.</p>

sound of the engine.

Investigate the cause of the fault on any cylinder that is operating below normal performance.

Result: There is a noticeable change in the sound of the engine for each cylinder.

Contact the Dealer Solution Network (DSN).

CAT C3.4B Engine Parts

Contact phone: 269 673 1638

Email: EngineParts@HeavyEquipmentRestorationParts.com

Alternate email: engineparts2@gmail.com

Website: www.CATC34B.com

Related website: www.HeavyEquipmentRestorationParts.com

www.FPTIndustrialEngineParts.com



Previous Screen



Troubleshooting
C3.4B Engines

Media Number -UENR0611-10

Publication Date -01/02/2015

i06225015

Engine Vibration Is Excessive

SMCS - 1000-035; 1152-035; 3252-035

Refer to Systems Operation, Testing, and Adjusting for additional information on determining the cause of this condition.

Probable Causes

- Engine supports
- Driven equipment
- Low compression (cylinder pressure)
- Electronic unit injectors
- Individual malfunctioning cylinder

Recommended Actions

Note: Complete the procedure in the order in which the steps are listed.

Table 1

Troubleshooting Test Steps	Values	Results
<p>1. Engine Supports</p> <p>A. Inspect the mounts and the brackets while you run the engine through the speed range. Look for mounts and brackets that are loose and/or broken.</p> <p>B. Check the alignment of the following before operating the engine under load for</p>	<p>Engine supports</p>	<p>Result: The mounts and brackets are loose and/or broken.</p> <p>Repair: Replace the mounts and brackets that are loose and/or broken.</p> <p>Result: The mounts and brackets are not loose and/or broken.</p>

<p>any length of time:</p> <ul style="list-style-type: none"> · Mounts · Coupling 		<p>Proceed to Test Step 2.</p>
<p>2. Driven Equipment</p> <p>A. Inspect the mounting bolts for the driven equipment. Inspect the alignment and the balance of the driven equipment.</p> <p>B. Inspect the coupling.</p>	<p>Driven equipment</p>	<p>Result The driven equipment and the alignment are not OK.</p> <p>Repair: Repair or replace the driven equipment.</p> <p>Result: The driven equipment and the alignment are OK.</p> <p>Proceed to Test Step 3.</p>
<p>3. Low Compression (Cylinder Pressure)</p> <p>A. Perform a compression test. Refer to Systems Operation, Testing, and Adjusting, "Compression - Test ".</p>	<p>Low compression</p>	<p>Result: Low compression is recorded on one or more cylinders.</p> <p>Repair: Possible causes of low compression are shown in the following list:</p> <ul style="list-style-type: none"> ·Loose glow plugs ·Faulty piston ·Faulty piston rings ·Worn cylinder bores ·Worn valves ·Faulty cylinder head gasket ·Damaged cylinder head <p>Make any repairs, as necessary.</p> <p>Result: No faults found.</p> <p>Proceed to Test Step 4.</p>
<p>4. Electronic Unit Injectors</p> <p>A. Use the electronic service tool to check for active diagnostic codes that relate to the electronic unit injectors.</p>	<p>Diagnostic codes</p>	<p>Result: There are active diagnostic codes for the fuel injectors</p> <p>Repair: Troubleshoot the active diagnostic codes. Refer to Troubleshooting, "Diagnostic Trouble Codes"</p> <p>Result: There are no active diagnostic codes for the fuel</p>

		<p>injectors.</p> <p>Proceed to Test Step 5.</p>
<p>5. Individual Malfunctioning Cylinders</p> <p>A. With the engine speed at a fast idle, use the electronic service tool to perform the manual "Cylinder Cut Out Test". As each cylinder is cut out, listen for a change in the sound from the engine. When a cylinder is cut out, there should be a noticeable change in the sound of the engine.</p>	<p>Cylinders</p>	<p>Result: There is not a noticeable change in the sound of the engine for at least one cylinder.</p> <p>Repair: Investigate the cause of the fault on any cylinder that is not operating. Investigate the cause of the fault on any cylinder that is operating below normal performance.</p> <p>Result: There is a noticeable change in the sound of the engine for each cylinder.</p> <p>Contact the Dealer Solution Network (DSN).</p>

CAT C3.4B Engine Parts

Contact phone: 269 673 1638

Email: EngineParts@HeavyEquipmentRestorationParts.com

Alternate email: engineparts2@gmail.com

Website: www.CATC34B.com

Related website: www.HeavyEquipmentRestorationParts.com

www.FPTIndustrialEngineParts.com



Troubleshooting

C3.4B Engines

Media Number -UENR0611-10

Publication Date -01/02/2015

i06004613

Exhaust Has Excessive Black Smoke

SMCS - 1088-035; 1250-035

If excessive black smoke is caused by a fault in the engine, and the engine is equipped with a wall-flow Diesel Particulate Filter (DPF), the smoke will only be visible when the DPF has also failed. Perform the following procedure to diagnose the cause of the black smoke and then investigate the failure of the DPF.

A faulty DPF will allow some smoke to be visible. In this situation, there may not be a fault in the engine.

If excessive black smoke is caused by a fault in the engine, and the engine is equipped with a through-flow DPF, the DPF will allow some smoke to be visible. This condition does not mean that the DPF has failed.

Note: If the DPF is replaced as part of this procedure, use the electronic service tool to perform the "DPF Replacement Reset".

Note: If the DPF is replaced as part of this procedure, use the electronic service tool to perform the "DPF Replacement Reset".

Probable Causes

- Diagnostic codes
- Parameters in the Electronic Control Module (ECM)
- Air intake system or exhaust system
- Valve lash
- Turbocharger
- Low compression (cylinder pressure)
- Electronic unit injectors

- Individual malfunctioning cylinder

Recommended Actions

Note: Complete the procedure in the order in which the steps are listed.

Table 1

Troubleshooting Test Steps	Values	Results
<p>1. Diagnostic Codes</p> <p>Note: Certain diagnostic codes and/or event codes may cause poor performance. Refer to in the electronic service tool.</p> <p>A. Use the electronic service tool to check for active or logged codes.</p>	<p>Engine Derate or Diagnostic Codes</p>	<p>Result: A diagnostic code is present.</p> <p>Troubleshoot the code. Refer to Troubleshooting, "Diagnostic Trouble Codes"</p> <p>Result: A diagnostic code is not present. Proceed to Test Step 2.</p>
<p>2. Parameters in the Electronic Control Module (ECM)</p> <p>A. Use the electronic service tool to verify that the correct parameters are being used. Refer to Troubleshooting, "Configuration Parameters" for additional information.</p>	<p>Parameters</p>	<p>Result: The parameters are not correct.</p> <p>Input the correct parameters. Refer to Troubleshooting, "Configuration Parameters" for additional information.</p> <p>Result: The parameters are correct.</p> <p>Proceed to Test Step 3.</p>
<p>3. Air Intake and Exhaust System</p> <p>A. Check the air filter restriction indicator, if equipped. Replace a plugged air filters. Refer to the Operation and Maintenance Manual.</p> <p>B. Check the air inlet and exhaust system for restrictions and/or leaks. Refer to Systems Operation, Testing and Adjusting, "Air Inlet and Exhaust System - Inspect"</p>	<p>Restrictions</p>	<p>Result: There are restrictions in the air inlet or exhaust system.</p> <p>Make the necessary repairs, Refer to Systems Operation/Testing and Adjusting, "Air Inlet and Exhaust System - Inspect" for additional information.</p> <p>Result: There are no restrictions in the air inlet or exhaust system.</p>

		Proceed to Test Step 4.
<p>4. Valve Lash</p> <p>A. Check the valve lash. Refer to Systems Operation, Testing, and Adjusting, "Engine Valve Lash - Inspect/Adjust".</p>	Valve lash	<p>Result: The valve lash is not set correctly.</p> <p>Set the valve lash. Refer to Systems Operation, Testing, and Adjusting, "Engine Valve Lash - Inspect/Adjust" for the correct procedure.</p> <p>Result: The valve lash is correct.</p> <p>Proceed to Test Step 5.</p>
<p>5. Turbocharger</p> <p>Note: The turbocharger that is installed on the engine is a non-serviceable item. If any mechanical fault exists, then the faulty turbocharger must be replaced.</p> <p>A. Ensure that the mounting bolts for the turbocharger are tight.</p> <p>B. Check that the oil drain for the turbocharger is not blocked or restricted.</p> <p>C. Check that the compressor housing for the turbocharger is free of dirt and debris. Make sure that the housing is not damaged.</p> <p>D. Check that the turbine housing for the turbocharger is free of dirt and debris. Make sure that the housing is not damaged.</p> <p>E. Check that the turbine blades rotate freely in the turbocharger.</p> <p>F. Ensure that the wastegate on the turbocharger is adjusted correctly. Refer to Systems Operation, Testing, and Adjusting, "Turbocharger - Inspect". If the wastegate actuator is faulty, replace the turbocharger. Refer to Disassembly and Assembly, "Turbocharger - Remove" and Disassembly and Assembly, "Turbocharger - Install".</p>	Turbocharger	<p>Result: There is a fault on the turbocharger.</p> <p>Repair the turbocharger or replace the turbocharger. Refer to Disassembly and Assembly, "Turbocharger - Remove" and Disassembly and Assembly, "Turbocharger - Install".</p> <p>Result: The turbocharger is OK.</p> <p>Proceed to Test Step 6.</p>

<p>6. Low Compression (Cylinder Pressure)</p> <p>A. Perform a compression test. Refer to Systems Operation, Testing, and Adjusting, "Compression - Test ".</p>	<p>Low compression</p>	<p>Result: Low compression is recorded on one or more cylinders.</p> <p>Possible causes of low compression are shown in the following list:</p> <ul style="list-style-type: none"> ·Loose glow plugs ·Faulty piston ·Faulty piston rings ·Worn cylinder bores ·Worn valves ·Faulty cylinder head gasket ·Damaged cylinder head <p>Make any repairs, as necessary.</p> <p>Result: No faults found.</p> <p>Proceed to Test Step 7.</p>
<p>7. Electronic Unit Injectors</p> <p>A. Use the electronic service tool to check for active diagnostic codes that relate to the electronic unit injectors.</p>	<p>Diagnostic codes</p>	<p>Result: There are active diagnostic codes for the fuel injectors</p> <p>Troubleshoot the active diagnostic codes. Refer to Troubleshooting, "Diagnostic Trouble Codes"</p> <p>Result: There are no active diagnostic codes for the fuel injectors.</p> <p>Proceed to Test Step 8.</p>
<p>8. Individual Malfunctioning Cylinders</p> <p>A. With the engine speed at a fast idle, use the electronic service tool to perform the manual "Cylinder Cut Out Test". As each cylinder is cut out, listen for a change in the sound from the engine. When a cylinder is cut out, there should be a noticeable change in the sound of the engine.</p>	<p>Cylinders</p>	<p>Result: There is not a noticeable change in the sound of the engine for at least one cylinder.</p> <p>Investigate the cause of the fault on any cylinder that is not operating. Investigate the cause of the fault on any cylinder that is operating below normal performance.</p>

		<p>Result: There is a noticeable change in the sound of the engine for each cylinder.</p>
--	--	--

Contact the Dealer Solution Network (DSN).

CAT C3.4B Engine Parts

Contact phone: 269 673 1638

Email: EngineParts@HeavyEquipmentRestorationParts.com

Alternate email: engineparts2@gmail.com

Website: www.CATC34B.com

Related website: www.HeavyEquipmentRestorationParts.com

www.FPTIndustrialEngineParts.com



Previous Screen



Troubleshooting
C3.4B Engines

Media Number -UENR0611-10

Publication Date -01/02/2015

i06006429

Exhaust Has Excessive White Smoke

SMCS - 1088-035; 1250-035

Note: Some white smoke may be present during cold start-up conditions and during acceleration after a prolonged period at low idle. If the white smoke persists, there may be a fault.

Probable Causes

- Diagnostic codes
- ECM Flash file
- Starting aids
- Coolant temperature
- Cooling system
- Fuel quality
- Valve lash
- Low compression (cylinder pressure)
- Individual malfunctioning cylinder

Recommended Actions

Diagnostic Codes

Note: The procedures have been listed in order of probability. Complete the procedures in order.

Table 1

Troubleshooting Test Steps	Values	Results

<p>1. Diagnostic Codes</p> <p>A. Establish communication between the electronic service tool and the Electronic Control Module (ECM) . Refer to Troubleshooting, "Electronic Service Tools", if necessary.</p> <p>B. Use the electronic service tool to check for active diagnostic</p>	<p>Diagnostic codes</p>	<p>Result: There are active diagnostic codes.</p> <p>Troubleshoot any active codes before continuing with this procedure. Refer to Troubleshooting, "Diagnostic Trouble Codes".</p> <p>Result: There are no active diagnostic codes.</p> <p>Proceed to Test Step 2.</p>
<p>2. ECM Flash File</p> <p>A. Verify that the latest flash file is installed in the ECM.</p>	<p>Flash file</p>	<p>Result: The latest flash file is not installed.</p> <p>Install the latest flash file. Refer to Troubleshooting, "ECM Software - Install" for the correct procedure. Verify that the repair eliminates the fault.</p> <p>Result: The latest flash file is installed.</p> <p>Proceed to Test Step 3.</p>
<p>3. Glow Plugs</p> <p>A. Check the operation of the glow plug circuit. Refer to Troubleshooting, "Glow Plug Starting Aid - Test".</p>	<p>Glow plugs</p>	<p>Result: The glow plugs are not operating correctly.</p> <p>Make the necessary repairs. Verify that the repair corrected the fault.</p> <p>Result: The glow plugs are operating correctly.</p> <p>Proceed to Test Step 4.</p>
<p>4. Coolant Temperature</p> <p>A. Check that the water temperature regulator is operating correctly. Refer to Systems Operation, Testing, and Adjusting, "Water Temperature Regulator - Test".</p>	<p>Coolant temperature</p>	<p>Result: The water temperature regulator is not operating correctly.</p> <p>Replace the water temperature regulator. Verify that the repair corrected the fault.</p> <p>Result: The water temperature regulator is operating correctly.</p>

		Proceed to Test Step 5.
<p>5. Cooling System</p> <p>A. Check for an internal coolant leak into the cylinder and/or the exhaust. Refer to Systems Operation/Testing and Adjusting, "Cooling System".</p>	Internal coolant leak	<p>Result: There is an internal coolant leak.</p> <p>Make the necessary repairs. Verify that the repair eliminated the fault.</p> <p>Result: There is not an internal coolant leak.</p> <p>Proceed to Test Step 6.</p>
<p>6. Fuel Quality</p> <p>A. Check the fuel quality. Refer to Systems Operation, Testing, and Adjusting, "Fuel Quality - Test".</p> <p>B. Refer to Operation and Maintenance Manual for information on the proper characteristics of the fuel for the engine.</p>	Fuel	<p>Result: The fuel quality is not OK.</p> <p>Drain the fuel system and replace the fuel filters. Refer to the Operation and Maintenance Manual, "Fuel System Primary Filter (Water Separator) Element - Replace" and Operation and Maintenance Manual, "Fuel System Filter - Replace".</p> <p>Fill the fuel system with fuel that meets the standard in the Operation and Maintenance Manual, "Fluid Recommendations".</p> <p>Prime the fuel system. Refer to the Operation and Maintenance Manual, "Fuel System - Prime".</p> <p>Verify that the procedure has eliminated the noise.</p> <p>Result: The fuel quality is OK.</p> <p>Proceed to Test Step 7.</p>
<p>7. Valve Lash</p> <p>Note: Excessive valve lash will cause a change in the timing of the opening and closing of the inlet and exhaust valves. Excessive valve lash can cause a reduction of the flow of combustion air into the engine. Reduced flow of</p>	Valve lash	<p>Result: The valve lash is excessive.</p> <p>The hydraulic lifter will compensate for all normal wear of the components of the valve train.</p> <p>Repair or replace any excessively worn or damaged components of the valve train.</p>

<p>combustion air will increase the fuel consumption rate.</p> <p>A. Check the valve lash. Refer to Systems Operation, Testing, and Adjusting, "Engine Valve Lash - Inspect/Adjust".</p>		<p>Result: The valve lash is correct.</p> <p>Proceed to Test Step 8.</p>
<p>8. Low Compression (Cylinder Pressure)</p> <p>A. Perform a compression test. Refer to Systems Operation, Testing, and Adjusting, "Compression - Test".</p>	<p>Low compression</p>	<p>Result: Low compression is recorded on one or more cylinders.</p> <p>Possible causes of low compression are shown in the following list:</p> <ul style="list-style-type: none"> ·Loose glow plugs ·Faulty piston ·Faulty piston rings ·Worn cylinder bores ·Worn valves ·Faulty cylinder head gasket ·Damaged cylinder head <p>Make any repairs, as necessary. Attempt to start the engine. If the engine will not start, contact the Dealer Solution Network (DSN).</p> <p>Result: No faults found.</p> <p>Proceed to Test Step 9.</p>
<p>9. Individual Malfunctioning Cylinders</p> <p>A. With the engine speed at a fast idle, use the electronic service tool to perform the manual "Cylinder Cut Out Test". As each cylinder is cut out, listen for a change in the sound from the engine. When a cylinder is cut out, there should be a noticeable change in the sound of the engine.</p>	<p>Cylinders</p>	<p>Result: There is not a noticeable change in the sound of the engine for at least one cylinder.</p> <p>Investigate the cause of the fault on any cylinder that is not operating. Investigate the cause of the fault on any cylinder that is operating below normal performance.</p> <p>Result: There is a noticeable change in the sound of the engine for each cylinder.</p> <p>Contact the Dealer Solution Network (DSN).</p>

CAT C3.4B Engine Parts

Contact phone: 269 673 1638

Email: EngineParts@HeavyEquipmentRestorationParts.com

Alternate email: engineparts2@gmail.com

Website: www.CATC34B.com

Related website: www.HeavyEquipmentRestorationParts.com

www.FPTIndustrialEngineParts.com



Previous Screen



Troubleshooting
C3.4B Engines

Media Number -UENR0611-10

Publication Date -01/02/2015

i06225022

Exhaust System Contains Coolant

SMCS - 1050-035; 1395-035

Use the following procedure to troubleshoot a problem with coolant in the exhaust system.

Probable Causes

- Exhaust Gas Recirculation (EGR) cooler leak
- Cylinder head gasket leak
- Cylinder head leak

Recommended Actions

Note: The procedures have been listed in order of probability. Complete the procedures in order.

Table 1

Troubleshooting Test Steps	Values	Results
<p>1. EGR cooler</p> <p>A. Check the EGR cooler for leaks for utilizing the "On Engine Test Procedure". Refer to Systems Operation, Testing and Adjusting, "Exhaust Cooler (NRS) - Test".</p>	EGR Cooler	<p>Result : The EGR cooler has a leak.</p> <p>Repair: Replace the EGR cooler. Refer to the Disassembly and Assembly manual for the correct procedure.</p> <p>Proceed to Step 5.</p> <p>Result : The EGR cooler does not have a leak.</p>

		Proceed to Test Step 2.
<p>2. Cylinder head gasket leak</p> <p>A. Check the cylinder head gasket for leaks. Refer to the Systems Operation/Testing and Adjusting for the proper procedure for checking the cylinder head.</p>	Cylinder Head Gasket	<p>Result : The cylinder head gasket is leaking.</p> <p>Repair: Replace the cylinder head gasket. Refer to the Disassembly and Assembly manual.</p> <p>Result : The cylinder head gasket is not leaking.</p> <p>Proceed to Test Step 3.</p>
<p>3. Cylinder head</p> <p>A. Check for cracks in the cylinder head. Perform a leak test on the cylinder head. Refer to the Systems Operation/Testing and Adjusting for the proper procedure for checking the cylinder head.</p>	Cylinder Head	<p>Result : A crack is found in the cylinder head.</p> <p>Repair: Repair the cylinder head and/or replace the cylinder head. Refer to the Disassembly and Assembly manual.</p> <p>Result : There are no cracks in the cylinder head.</p> <p>Contact the Dealer Solution Network (DSN).</p>

CAT C3.4B Engine Parts
Contact phone: 269 673 1638
Email: EngineParts@HeavyEquipmentRestorationParts.com
Alternate email: engineparts2@gmail.com
Website: www.CATC34B.com
Related website: www.HeavyEquipmentRestorationParts.com

www.FPTIndustrialEngineParts.com



Previous Screen



Troubleshooting
C3.4B Engines

Media Number -UENR0611-10

Publication Date -01/02/2015

i06225084

Exhaust System Contains Oil

SMCS - 1050-035; 1348-035

Probable Causes

- Extended idle times
- Failed turbocharger seals
- Worn valve guide seals or faulty valve guide seals
- Worn valve guides
- Worn piston rings

Complete the procedure in the order in which the steps are listed.

Table 1

Troubleshooting Test Steps	Values	Results
<p>1. Extended Idle Times</p> <p>A. Extended idle times will allow oil to pass into the exhaust system.</p>	<p>Idle times</p>	<p>Result The idle times are extensive.</p> <p>Repair: Reduce the idle times.</p> <p>Result The idle times are not extensive.</p> <p>Proceed to Test Step 2.</p>
<p>2. Failed Turbocharger Seals</p>	<p>Turbo</p>	<p>Result: Oil is present in the inlet or exhaust manifold.</p>

<p>A. Check the inlet manifold and the exhaust manifold for oil.</p>	<p>seals</p>	<p>Repair: Replace the turbocharger. Verify the repair.</p> <p>Result: Oil is not present in the inlet or exhaust manifold.</p> <p>Proceed to Test Step 3.</p>
<p>3. Worn Valve Guide Seals or Faulty Valve Guide Seals</p> <p>A. Inspect the valve guide seals for wear and for damage.</p>	<p>Valve guide seals</p>	<p>Result: The valve guide seals are damaged.</p> <p>Repair: Replace the valve guide seals. Verify the repair.</p> <p>Result: The valve guide seals are not damaged.</p> <p>Proceed to Test Step 4.</p>
<p>4. Worn Valve Guides</p> <p>A. Inspect the valve guides for wear. Refer to the Specification manual for the maximum permissible wear of the valve guides.</p>	<p>Valve guides</p>	<p>Result: The valve guides are worn.</p> <p>If necessary, recondition the cylinder head. Verify the repair.</p> <p>Result: The valve guides are not worn.</p> <p>Proceed to Test Step 5.</p>
<p>5. Worn Piston Rings</p> <p>A. Remove the pistons. Refer to Disassembly and Assembly, "Pistons and Connecting Rods - Remove".</p> <p>B. Remove the piston rings from the pistons. Refer to Disassembly and Assembly, "Pistons and Connecting Rods - Disassemble"</p> <p>C. Inspect the pistons and piston rings for wear or damage. Refer to the "Specifications" manual for</p>	<p>Piston rings</p>	<p>Result The piston rings are worn.</p> <p>Repair: Replace the piston rings. Verify the repair.</p> <p>Result The piston rings are not worn.</p> <p>Contact the Dealer Solution Network (DSN).</p>

further information.

--	--	--

**Troubleshooting**
C3.4B Engines

Media Number -UENR0611-10

Publication Date -01/02/2015

i06225091

Fuel Consumption Is Excessive

SMCS - 1250-035

Probable Causes

- Diagnostic codes
- Misreading of fuel level
- Fuel leakage
- Fuel quality
- Quality of oil
- Engine accessories and transmission
- Coolant temperature
- Prolonged operation at idle speed
- Engine operating speed
- Air intake and exhaust system
- Cooling fan
- Reduced pressure of intake air
- Valve lash

Recommended Actions

Note: The procedures have been listed in order of probability. Complete the procedures in order.

Troubleshooting Test Steps	Values	Results
<p>1. Diagnostic Codes</p> <p>Note: Certain diagnostic codes and/or event codes indicate the cause of high fuel consumption.</p> <p>A. Use the electronic service tool to check for active or logged codes.</p>	Diagnostic codes	<p>Result: A diagnostic code is present.</p> <p>Repair: Troubleshoot the diagnostic code and then verify that the fuel consumption is normal. Refer to Troubleshooting, "Diagnostic Trouble Codes".</p> <p>Result: A diagnostic code is not present. Proceed to Test Step 2.</p>
<p>2. Misreading of Fuel Level</p> <p>Note: Misreading of the fuel gauge can give a false indication of fuel consumption.</p> <p>A. Monitor the fuel consumption over a period of 50 engine hours.</p>	Fuel level	<p>Result: Fuel consumption is normal for the operating conditions.</p> <p>Return the unit to service.</p> <p>Result: Fuel consumption is high for the operating conditions.</p> <p>Proceed to Test Step 3.</p>
<p>3. Fuel Leakage</p> <p>A. Check the engine for signs of fuel leakage.</p>	Fuel leaks	<p>Result: Evidence of a fuel leak is found.</p> <p>Repair: Repair or replace the component that is leaking fuel.</p> <p>Result: No evidence of a fuel leak is found.</p> <p>Proceed to Test Step 4.</p>
<p>4. Fuel Quality</p> <p>Note: The grade of the fuel affects the rate of fuel consumption. Refer to the engines Operation and Maintenance Manual for additional information.</p> <p>Cold weather adversely affects the characteristics of the fuel. Refer to the Operation and Maintenance Manual for</p>	Fuel quality	<p>Result: The fuel quality does not meet specifications.</p> <p>Repair: Drain the fuel system and replace the fuel filters. Refer to the Operation and Maintenance Manual, "Fuel System Primary Filter (Water Separator) Element - Replace" and Operation and Maintenance Manual, "Fuel</p>

<p>information on improving the characteristics of the fuel during cold-weather operation.</p> <p>A. Check the fuel quality. Refer to Systems Operation, Testing, and Adjusting, "Fuel Quality - Test".</p> <p>B. Refer to Operation and Maintenance Manual for information on the proper characteristics of the fuel for the engine.</p>		<p>System Filter - Replace".</p> <p>Fill the fuel system with fuel that meets the standard in the Operation and Maintenance Manual, "Fluid Recommendations".</p> <p>Prime the fuel system. Refer to the Operation and Maintenance Manual, "Fuel System - Prime".</p> <p>Result: The fuel quality meets specifications.</p> <p>Proceed to Test Step 5.</p>
<p>5. Quality of Oil</p> <p>Note: The nominal viscosity of the lubricating oil that is used in the engine will affect the rate of fuel consumption. The viscosity of lubricating oil is defined by the SAE grade of the lubricating oil. The grade of the lubricating oil must be correct for the ambient conditions. Lubricating oil for high ambient temperatures will affect fuel consumption in cold ambient temperatures.</p> <p>A. Check that the engine oil meets the required specification. Refer to "Engine Oil" in the Operation and Maintenance Manual, "Refill Capacities".</p>	<p>Engine oil quality</p>	<p>Result: The engine oil does not meet the required specification.</p> <p>Repair: Refill the oil system with oil of an acceptable quality. Refer to the applicable sections in the Operation and Maintenance Manual.</p> <p>Result: The engine oil meets the required specification.</p> <p>Proceed to Test Step 6.</p>
<p>6. Engine Accessories and Transmission</p> <p>A. Check that the engine accessories and transmission are operating correctly.</p> <p>B. Remove and inspect any engine accessories that may be adding unexpected load to the engine.</p>	<p>Engine accessories and transmission</p>	<p>Result: The engine accessories and transmission are not OK.</p> <p>Repair: Make the necessary repairs.</p> <p>Result: The engine accessories and transmission are OK.</p> <p>Proceed to Test Step 7.</p>
<p>7. Coolant Temperature</p> <p>Note: The operating temperature of the</p>	<p>Coolant temperature</p>	<p>Result: The water temperature regulator is not operating correctly.</p>

<p>engine will affect the rate of fuel consumption. Operation of the engine below the correct temperature will increase fuel consumption. Failure of the water temperature regulator can prevent the engine from operating at the correct temperature.</p> <p>A. Check that the water temperature regulator is operating correctly. Refer to Systems Operation, Testing, and Adjusting, "Water Temperature Regulator - Test".</p>		<p>Repair: Replace the water temperature regulator. Verify that the repair corrected the fault.</p> <p>Result: The water temperature regulator is operating correctly.</p> <p>Proceed to Test Step 8.</p>
<p>8. Prolonged Operation at Idle Speed</p> <p>Note: Prolonged operation of the engine at idle speed increases fuel consumption.</p> <p>A. Check for extended periods of engine operation at idle speed.</p>	<p>Extended idle operation</p>	<p>Result: The engine is operating at idle speed for extended periods.</p> <p>Repair: When possible, stop the engine to conserve fuel.</p> <p>Result: The engine is not operating at idle speed for extended periods.</p> <p>Proceed to Test Step 9.</p>
<p>9. Engine Operating Speed</p> <p>The operating speed of the engine will affect the rate of fuel consumption. High engine speed will increase fuel consumption. At high engine speeds, internal power losses in the engine increase and more power is required to drive the alternator and the fan. These losses of power increase fuel consumption.</p> <p>Lugging down the engine to a low engine speed will increase fuel consumption. At low engine speeds, the combustion efficiency of the engine is reduced and more fuel is required.</p> <p>A. Check that the engine has been operated at a suitable engine speed.</p>	<p>Engine speed</p>	<p>Result: The engine has been operated at an unsuitable speed.</p> <p>Operate the engine at a suitable speed.</p> <p>Result: The engine has been operated at a suitable speed.</p> <p>Proceed to Test Step 10.</p>
<p>10. Air Intake and Exhaust System</p> <p>A. Check the air filter restriction indicator, if equipped.</p>	<p>Air and Exhaust System</p>	<p>Result: The air filter is restricted.</p> <p>Repair: Replace the air filter.</p>

<p>B. Check the air intake and exhaust systems for the following defects:</p> <ul style="list-style-type: none"> · Blockages · Restrictions · Damage to lines or hoses <p>Refer to Systems Operation, Testing and Adjusting, "Air Inlet and Exhaust System - Inspect".</p>	<p>restrictions</p>	<p>Result: There are system restrictions.</p> <p>Repair: Repair any defects in the air inlet and exhaust systems.</p> <p>Result: The air intake and exhaust system is OK.</p> <p>Proceed to Test Step 11.</p>
<p>11. Cooling Fan</p> <p>Excessive operation of the cooling fan will increase fuel consumption.</p> <p>A. Check the operation of the cooling fan.</p>	<p>Cooling fan</p>	<p>Result: The cooling fan is operating excessively.</p> <p>Repair: Repair or replace the faulty cooling fan components.</p> <p>Result: The cooling fan is not operating excessively.</p> <p>Proceed to Test Step 12.</p>
<p>12. Reduced Pressure of Intake Air</p> <p>Note: If the air pressure is lower than normal, the same power can only be achieved by the following:</p> <ul style="list-style-type: none"> · Higher engine speed · Injection of more fuel <p>Either of these conditions will increase the fuel consumption.</p> <p>A. Check all pipes from the outlets of the turbocharger compressor to the inlet manifold for leaks.</p> <p>B. Check for the correct operation of the wastegate in the turbocharger. Refer to Systems Operation, Testing and Adjusting, "Turbocharger - Inspect".</p>	<p>Intake air</p>	<p>Result: There is a leak in the intake air system.</p> <p>Repair: Repair the leak or replace the component that is causing the leak.</p> <p>Result: The turbocharger wastegate is not operating correctly.</p> <p>Repair: Replace the turbocharger.</p> <p>Result: The air intake system and the wastegate are OK.</p> <p>Proceed to Test Step 13.</p>
<p>13. Valve Lash</p> <p>Note: Excessive valve lash will cause a change in the timing of the opening and closing of the inlet and exhaust valves.</p>	<p>Valve lash</p>	<p>Result: The valve lash is excessive.</p> <p>The hydraulic lifter will compensate for all normal wear of</p>

Excessive valve lash can cause a reduction of the flow of combustion air into the engine. Reduced flow of combustion air will increase the fuel consumption rate.

A. Check the valve lash. Refer to Systems Operation, Testing, and Adjusting, "Engine Valve Lash - Inspect".

the components of the valve train.

Repair: Repair or replace any excessively worn or damaged components of the valve train.

Result: The valve lash is correct.

Contact the Dealer Solution Network (DSN).

CAT C3.4B Engine Parts

Contact phone: 269 673 1638

Email: EngineParts@HeavyEquipmentRestorationParts.com

Alternate email: engineparts2@gmail.com

Website: www.CATC34B.com

Related website: www.HeavyEquipmentRestorationParts.com

www.FPTIndustrialEngineParts.com



Previous Screen



Troubleshooting
C3.4B Engines

Media Number -UENR0611-10

Publication Date -01/02/2015

i06225799

Fuel Contains Water

SMCS - 1250-035

This procedure covers the following diagnostic code:

Table 1

Diagnostic Trouble Codes for Fuel Contains Water		
J1939 Code	Description	Notes
97-15	Water In Fuel Indicator : High - least severe (1)	The Electronic Control Module (ECM) detects the presence of water in the fuel for at least 60 seconds. If equipped, the warning lamp will come on. The fault will be cleared when no fuel is detected for at least 0.6 seconds.

Note: Visual identification of water in the bowl may be impossible. Water may turn dark yellow in color in the fuel system. The similarity in color would prevent the ability to differentiate the water from the fuel.

Recommended Actions

Note: Complete the procedure in the order in which the steps are listed.

Table 2

Troubleshooting Test Steps	Values	Results
1. Drain the Fuel/Water Separator Bowl A. Turn the ignition key to the OFF position.	Fuel/water separator	Result: The "Water-In-Fuel" warning disappears within 1 minute.

<p>B. Drain the fuel/water separator bowl. Refer to the Operation and Maintenance Manual, "Fuel System Primary Filter/Water Separator - Drain".</p> <p>C. If necessary, prime the fuel system. Refer to the Operation and Maintenance Manual, "Fuel System - Prime".</p> <p>D. Turn the ignition key to the ON position. Do not start the engine. Wait for 1 minute.</p>		<p>Proceed to Test Step 2.</p> <p>Result: The "Water-In-Fuel" warning remains on.</p> <p>Proceed to Test Step 3.</p>
<p>2. Confirm That There is No Water in the Fuel</p> <p>A. Run the engine for 5 minutes.</p>	<p>Water in fuel</p>	<p>Result: The "Water-In-Fuel" warning does not reappear within the 5 minutes.</p> <p>Return the unit to service.</p> <p>Result: The "Water-In-Fuel" warning reappears within the 5 minutes.</p> <p>Repair: The fuel supply is contaminated with water. Drain the fuel tank and then fill the fuel tank with clean fuel.</p> <p>Repeat the procedure from Test Step 1.</p>
<p>3. Water-In-Fuel Switch</p> <p>A. Check the operation of the Water-In-Fuel switch. Refer to Troubleshooting, "Water In Fuel - Test".</p>	<p>Water in fuel switch</p>	<p>Result: The Water-In-Fuel switch required a repair.</p> <p>Repeat the procedure from Test Step 1.</p> <p>Result The Water-In-Fuel switch is OK.</p> <p>Repair: The fuel supply is contaminated with water. Drain the fuel tank and then fill the fuel tank with clean fuel.</p> <p>Repeat the procedure from Test Step 1.</p>

CAT C3.4B Engine Parts

Contact phone: 269 673 1638

Email: EngineParts@HeavyEquipmentRestorationParts.com

Alternate email: engineparts2@gmail.com

Website: www.CATC34B.com

Related website: www.HeavyEquipmentRestorationParts.com

www.FPTIndustrialEngineParts.com



Previous Screen



Troubleshooting
C3.4B Engines

Media Number -UENR0611-10

Publication Date -01/02/2015

i06704045

Fuel Rail Pressure Problem

SMCS - 1252-035; 127A-035

This procedure covers the following diagnostic codes:

Table 1

Diagnostic Trouble Codes for the Fuel Rail Pressure		
J1939 Code	Description	Notes
157-0	Engine Injector Metering Rail #1 Pressure : High - most severe (3)	The Electronic Control Module (ECM) detects the following conditions: The fuel rail pressure is greater than 179000 kPa (25962 psi) while the engine has been derated. If equipped, the warning lamp will flash and the shutdown lamp will come on. The engine will be shut down.
157-2	Engine Injector Metering Rail #1 Pressure : Erratic, Intermittent, or Incorrect	The ECM detects one of the following conditions: The amount of fuel delivered by the high-pressure fuel pump is greater than 480 mL/min (16.3 oz/min) for at least 2 seconds while the engine is at low idle. If equipped, the warning lamp will flash. The engine will be derated.
157-16	Engine Injector Metering Rail #1 Pressure : High - moderate severity (2)	The ECM detects one of the following conditions: The fuel rail pressure is greater than 170000 kPa (24657 psi) for at least 1 second. OR The measured fuel rail pressure is greater than the desired fuel rail pressure for at least 2 seconds.

		<p>OR</p> <p>The fuel pressure remains too high after the keyswitch has been turned to the OFF position.</p> <p>If equipped, the warning lamp will flash. The engine will be derated.</p>
157-17	Engine Injector Metering Rail #1 Pressure : Low - least severe (1)	<p>The ECM detects that the pressure in the fuel rail is low for at least 0.5 seconds. The point at which this diagnostic code becomes active is a calculated parameter based on engine speed and engine temperature.</p> <p>If equipped, the warning lamp will come on. The engine will shut down.</p>
157-18	Engine Injector Metering Rail #1 Pressure : Low - moderate severity (2)	<p>The ECM detects that the measured fuel rail pressure is lower than the desired fuel rail pressure for the current engine speed for at least 2 seconds.</p> <p>If equipped, the warning lamp will flash. Active regeneration will be disabled. The engine will be derated. The engine may shut down.</p>
1239-0	Engine Fuel Leakage 1 : High - most severe (3)	<p>The ECM detects that the pressure in the fuel rail is too low compared to the volume of fuel that is being supplied by the fuel injection pump.</p> <p>If equipped, the warning lamp will flash and the shutdown lamp will come on. The engine will be derated.</p>
5571-2	High Pressure Common Rail Fuel Pressure Relief Valve : Erratic, Intermittent, or Incorrect	<p>The ECM detects that the fuel rail pressure is out of the expected range after the fuel Pressure Relief Valve (PRV) has been opened. This can either be high pressure (relief valve not fully open) or low pressure (fuel leak).</p> <p>If equipped, the warning lamp will flash. The engine will be derated.</p>
5571-7	High Pressure Common Rail Fuel Pressure Relief Valve : Not Responding Properly	<p>The PRV has been activated.</p> <p>The PRV activation is caused by another active diagnostic code. Troubleshoot any other active diagnostic codes. This diagnostic code will clear when the other fault has been rectified.</p> <p>If equipped, the warning lamp will flash. The engine will shut down.</p>
5571-10	High Pressure Common Rail Fuel Pressure Relief Valve : Abnormal Rate of Change	<p>The ECM detects that the volume of fuel being delivered is too low to open the PRV during a PRV test.</p>

		If equipped, the warning lamp will flash. Troubleshoot any other diagnostic codes before attempting to test the PRV again.
5571-14	High Pressure Common Rail Fuel Pressure Relief Valve : Special Instruction	The ECM detects one of the following conditions: The PRV has been open for a total of at least 300 minutes. OR The PRV has been activated at least 50 times. Perform this procedure to identify the cause of the PRV activation before replacing the PRV. If equipped, the warning lamp will flash. The engine will be derated.
5571-16	High Pressure Common Rail Fuel Pressure Relief Valve : High - moderate severity (2)	The ECM detects that the PRV is open. If equipped, the warning lamp will flash. The engine will be derated. This code will be reset when the PRV is closed and the keyswitch has been cycled.

Use this procedure to troubleshoot abnormal fuel rail pressure.

Probable Causes

- Diagnostic trouble codes
- Electrical connectors
- Fuel filters
- Fuel rail pressure sensor
- Fuel system inspection
- Fuel rail Pressure Relief Valve (PRV)
- High-pressure fuel pump

Recommended Actions

Table 2

Troubleshooting Test Steps	Values	Results
1. Diagnostic Codes A. Connect the electronic service tool to the diagnostic connector. Refer to	Diagnostic codes	Result: One of the diagnostic codes listed in Table 1 is active. Proceed to Test Step 2.

<p>Troubleshooting, "Electronic Service Tools", if necessary.</p> <p>B. Use the electronic service tool to check for active diagnostic codes.</p>		<p>Result: A diagnostic code that is not listed in Table 1 is active.</p> <p>Repair: Troubleshoot the code. Refer to Troubleshooting, "Diagnostic Trouble Codes".</p> <p>Result: There are no active diagnostic codes.</p> <p>Return the engine to service.</p>
<p>2. Electrical Connectors</p> <p>A. Check for the correct installation of the ECM J1/P1 and the J2/P2 connectors. Check for correct installation of the connector on the fuel rail pressure sensor.</p>	Connectors	<p>Result: There are suspect connectors.</p> <p>Repair: Repair or replace connectors that are suspect.</p> <p>Result: There are no suspect connectors.</p> <p>Proceed to Test Step 3.</p>
<p>3. Fuel Filters</p> <p>A. Replace the primary fuel filter and the secondary fuel filters. Refer to the Operation and Maintenance Manual for further information.</p>	Fuel filters	<p>Result: The filters have been replaced and the fault is eliminated.</p> <p>Return the unit to service.</p> <p>Result: The filters have been replaced and the fault is still present.</p> <p>Proceed to Test Step 4.</p>
<p>4. Fuel Rail Pressure Sensor</p> <p>A. Make sure that the engine has been shut down for at least 10 minutes. Use the electronic service tool to check the status of the "Fuel Rail Pressure"</p>	Pressure sensor	<p>Result: The "Fuel Rail Pressure (absolute)" is more than 5,000 kPa (725 psi).</p> <p>Repair: Replace the fuel rail pressure sensor. Refer to Disassembly and Assembly, "Fuel Manifold (Rail) - Remove and Install".</p> <p>Confirm that the fault has been eliminated.</p> <p>Result: The "Fuel Rail Pressure</p>

		<p>(absolute)" is less than 5,000 kPa (725 psi).</p> <p>Proceed to Test Step 5.</p>
<p>5. Fuel System Inspection</p> <p>A. Check that the fuel shut-off valve is in the OPEN position.</p> <p>B. If the temperature is below 0 °C (32 °F), check for solidified fuel (wax).</p> <p>C. Check for fuel supply lines that are restricted.</p> <p>D. Check that the low-pressure fuel lines are correctly installed.</p> <p>E. Check the pressures in the fuel system. Refer to Systems Operation, Testing, and Adjusting, "Fuel System Pressure - Test"</p> <p>F. Check the diesel fuel for contamination. Refer to Systems Operation, Testing, and Adjusting, "Fuel Quality - Test".</p> <p>G. Check for air in the fuel system. Refer to Systems Operation, Testing, and Adjusting, "Air in Fuel - Test".</p> <p>H. Ensure that the fuel system has been primed. Refer to Systems Operation, Testing, and Adjusting, "Fuel System - Prime".</p>	<p>Fuel System</p>	<p>Result: A defect was found in the fuel system.</p> <p>Repair: Make any necessary repairs.</p> <p>Result: No defects found.</p> <p>Proceed to Test Step 6.</p>

CAT C3.4B Engine Parts
Contact phone: 269 673 1638
Email: EngineParts@HeavyEquipmentRestorationParts.com
Alternate email: engineparts2@gmail.com
Website: www.CATC34B.com
Related website: www.HeavyEquipmentRestorationParts.com

www.FPTIndustrialEngineParts.com

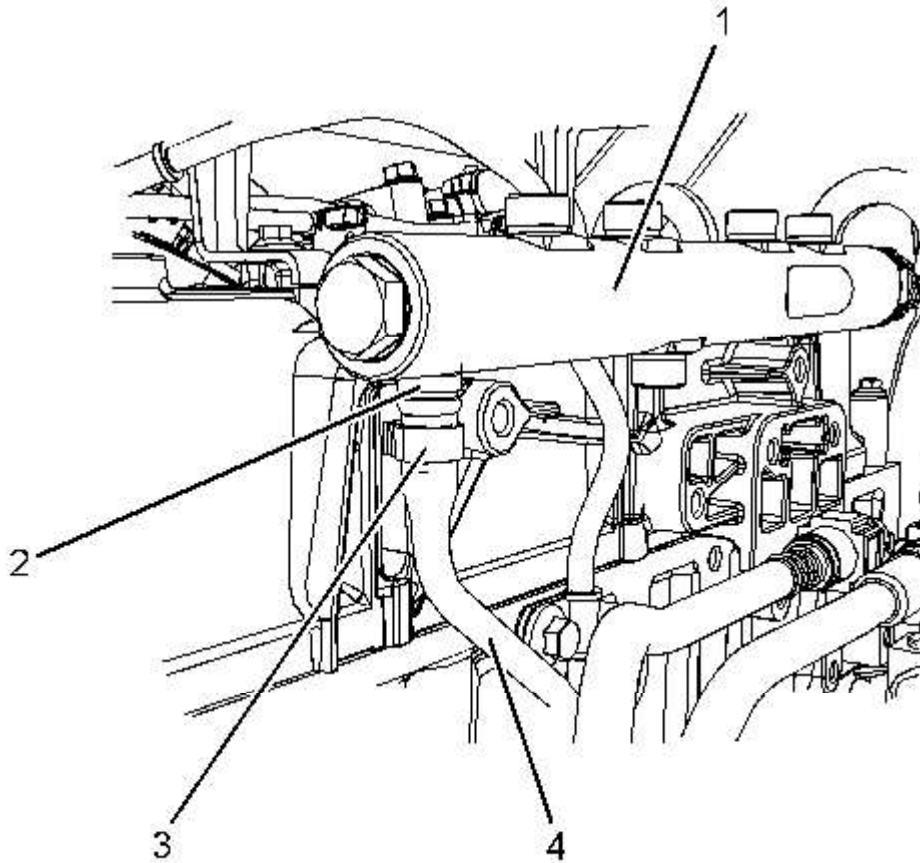

Illustration 1

g02859420

Table 3

Troubleshooting Test Steps	Values	Results
<p>6. Fuel Rail Pressure Relief Valve (PRV)</p> <p>A. Turn the keyswitch to the OFF position.</p> <p>B. Disconnect plastic tube assembly (4) from fuel manifold (1). Refer to Disassembly and Assembly, "Fuel Manifold (Rail) - Remove and Install".</p> <p>C. Securely seal the end of plastic tube assembly (4).</p> <p>Note: Plastic tube assembly (4) must be sealed to prevent air ingress into the fuel system.</p> <p>D. Attach a length of hose to fuel manifold (1) and secure with a clip at position (3).</p> <p>E. Place the other end of the hose into a container that is suitable for fuel. Ensure</p>	<p>Fuel in container</p>	<p>Result: Fuel is present in the container.</p> <p>Repair: Install a replacement fuel manifold. Refer to Disassembly and Assembly, "Fuel Manifold (Rail) - Remove and Install". When the fuel manifold has been replaced, use the electronic service tool to perform the "Rail Pressure Valve Learn Reset".</p> <p>Result: No fuel is present in the container.</p> <p>Proceed to Test Step 7.</p>

<p>that the hose is secure and will not come out of the container while the engine is running.</p> <p>F. Turn the keyswitch to the ON position.</p> <p>G. If the engine will start, use the electronic service tool to perform the "High Rail Pressure Test". This service test will run the engine with an elevated fuel rail pressure for a limited time. At this pressure, a PRV that is functioning correctly will remain closed. If the engine will not start, crank the engine for a maximum of 30 seconds.</p> <p>H. After the engine has stopped, check the container for fuel.</p>		
<p>7. High-Pressure Fuel Pump</p> <p>A. If all previous Test Steps have not identified a fault, and a fuel rail pressure diagnostic code is still active, replace the high-pressure fuel pump. Refer to Disassembly and Assembly, "Fuel Injection Pump - Remove" and refer to Disassembly and Assembly, "Fuel Injection Pump - Remove".</p> <p>B. Run the engine and use the electronic service tool to check for active diagnostic codes.</p>	<p>Diagnostic codes</p>	<p>Result: There are no active diagnostic codes.</p> <p>Return the engine to service.</p> <p>Result: A diagnostic code that is not listed in Table 1 is active.</p> <p>Repair: Troubleshoot the code. Refer to Troubleshooting, "Diagnostic Trouble Codes".</p> <p>Result: One of the diagnostic codes listed in Table 1 is still active.</p> <p>Contact the Dealer Solution Network (DSN).</p>

CAT C3.4B Engine Parts
Contact phone: 269 673 1638
Email: EngineParts@HeavyEquipmentRestorationParts.com
Alternate email: engineparts2@gmail.com
Website: www.CATC34B.com
Related website: www.HeavyEquipmentRestorationParts.com
www.FPTIndustrialEngineParts.com

[Previous Screen](#)

Troubleshooting

C3.4B Engines

Media Number -UENR0611-10

Publication Date -01/02/2015

i06225850

Fuel Temperature Is High

SMCS - 1250-035-TA

Probable causes

- Fuel level in tank
- Location of the fuel tank

Recommended Actions

Fuel Level in Tank

If the level in the fuel tank is low, the hot fuel from the high-pressure fuel system can raise the temperature in the fuel tank. Replenish the fuel tank at the earliest opportunity.

Location of the Fuel Tank

Make sure that the fuel tank is not close to a heat source. If necessary, shield the fuel tank from the heat source.



Troubleshooting

C3.4B Engines

Media Number -UENR0611-10

Publication Date -01/02/2015

Date Updated -02/11/2017

i06704782

General Information

SMCS - 1000

Important Safety Information

Do not perform any procedures in this Troubleshooting Guide until you have read the Operation and Maintenance Manual and you understand this information. Use only proper tools and observe all precautions that pertain to the use of those tools. Failure to follow these procedures can result in personal injury. The following procedures should also be observed.

Work safely. Most accidents that involve product operation, maintenance, and repair are caused by failure to observe basic safety rules or precautions. An accident can often be avoided by recognizing potentially hazardous situations before an accident occurs.

A person must be alert to potential hazards. This person should also have the necessary training, skills, and tools to perform these functions properly.

Safety precautions and warnings are provided in this publication and on the product. If these hazard warnings are not heeded, bodily injury or death could occur to you or to other persons. Caterpillar cannot anticipate every possible circumstance that might involve a potential hazard.

Therefore, the warnings in this publication and the warnings that are on the product are not all inclusive.

Overview

These engines are equipped with an electronic control system. The system consists of a computer, sensors, and software. The system performs these functions:

- Control of the engine
- Control of particulate emissions via the Clean Emission Module (CEM)
- Applications control system interface

- Fault detection and reporting

Electronic Control System

The Electronic Control Module (ECM) is a computer that controls the operation of the engine.

The ECM contains a flash file. The flash file is the software for the ECM. The flash file contains the operating maps. The operating maps define the following characteristics of the engine:

- Horsepower
- Torque curves
- Engine speed (rpm)

Refer to Troubleshooting, "System Overview" for additional information on the electronic control system.

Application Interface

The ECM interfaces with the machine via software and an electrical connector on the ECM. The software can be configured.

The application control system provides inputs to the electrical connector on the ECM to indicate the status of switches. Correctly configure the ECM to interpret the inputs.

The ECM provides outputs for the application control system via the electrical connector to control lamps, solenoids, and other devices. Correctly configure the ECM in order for the outputs to match the configuration of the application control system.

Clean Emissions Module (CEM)

The CEM contains these components:

Diesel Particulate Filter (DPF) - A DPF is installed in the exhaust system. The DPF collects soot and ash from the engine exhaust.

Software - Software in the ECM monitors the DPF.

Fault Detection and Reporting

The ECM monitors inputs from the sensors and inputs from the applications control system. Software in the ECM interprets the inputs. The software determines if the inputs are operating correctly. A diagnostic trouble code is activated when the software detects a problem with an input.

The ECM broadcasts the codes on the J1939 CAN data link. If a problem is suspected with the data link, refer to Troubleshooting, "Data Link - Test".

The codes can be displayed on the electronic service tool and optional operator interfaces. Refer to Troubleshooting, "Diagnostic Trouble Codes" for additional information on diagnostic trouble codes and a complete list of codes.

Troubleshooting

As a reference, simplified schematics for each of the engine subsystems are included with each of the circuit tests that are in this manual. For an accurate representation of the entire electrical schematic that is for your application, refer to the Electrical System Schematic.

During troubleshooting, inspect all harness connections before any component is replaced. If these connections are not clean and tight, continuous electrical problems or intermittent electrical problems can result. Check that the wires are pushed into the connectors completely. Make sure that the connections are tight before other tests are made.

Failure of an electrical component may cause the failure of other components. Always attempt to correct the cause of an electrical failure before you replace a component. If wire insulation is punctured, repair the damage. Seal the damaged wires with **8T-0065** Silicone Sealant. Cover the sealant with two layers of **1P-0810** Electrical Tape.

CAT C3.4B Engine Parts

Contact phone: 269 673 1638

Email: EngineParts@HeavyEquipmentRestorationParts.com

Alternate email: engineparts2@gmail.com

Website: www.CATC34B.com

Related website: www.HeavyEquipmentRestorationParts.com

www.FPTIndustrialEngineParts.com



Previous Screen



Troubleshooting

C3.4B Engines

Media Number -UENR0611-10

Publication Date -01/02/2015

i06704120

Glow Plug Starting Aid - Test

SMCS - 1412-038

This procedure covers the following diagnostic codes:

Table 1

Diagnostic Trouble Codes for the Glow Plug Start Aid Circuit		
J1939 Code	Description	Notes
676-5	Engine Glow Plug Relay : Current Below Normal	The Electronic Control Module (ECM) detects a low current condition in the control circuit for the Glow plug Control Unit (GCU) for at least 0.7 seconds. The warning lamp will come on.
676-6	Engine Glow Plug Relay : Current Above Normal	The ECM detects a high current condition in the control circuit for the GCU for at least 0.2 seconds. The ECM will attempt to activate the glow plug control unit for a further five attempts after the diagnostic code becomes active. The warning lamp will come on.
676-19	Engine Glow Plug Relay : Data Error	The ECM detects one of the following conditions: The diagnostic signal from the GCU indicates that there is an error in the GCU. OR The diagnostic signal from the GCU is invalid. The warning lamp will come on.
5324-7	Engine Glow Plug 1 : Not Responding Properly	The ECM detects the following conditions: The diagnostic signal from the GCU indicates that there is a short

		in the circuit for the glow plug for cylinder number 1.
5325-7	Engine Glow Plug 2 : Not Responding Properly	The ECM detects the following conditions: The diagnostic signal from the GCU indicates that there is a short in the circuit for the glow plug for cylinder number 2.
5326-7	Engine Glow Plug 3 : Not Responding Properly	The ECM detects the following conditions: The diagnostic signal from the GCU indicates that there is a short in the circuit for the glow plug for cylinder number 3.
5327-7	Engine Glow Plug 4 : Not Responding Properly	The ECM detects the following conditions: The diagnostic signal from the GCU indicates that there is a short in the circuit for the glow plug for cylinder number 4.

The following background information is related to this procedure:

The starting aid is used to improve the engine starting when the engine is cold. With the keyswitch in the ON position, the Electronic Control Module (ECM) will monitor the coolant temperature and the engine air inlet temperature to decide if the glow plugs need to be switched ON. If the glow plugs are required, then the ECM will activate the glow plug control unit for a controlled period. While the glow plug control unit is activated, the glow plug control unit will supply power to the glow plugs.

Glow plugs are used for temperatures that are below 5° C (41° F).

The GCU transmits a diagnostic signal back to the engine ECM. If the GCU detects a fault for one of the glow plugs, a diagnostic code will become active for that glow plug.

CAT C3.4B Engine Parts
Contact phone: 269 673 1638
Email: EngineParts@HeavyEquipmentRestorationParts.com
Alternate email: engineparts2@gmail.com
Website: www.CATC34B.com
Related website: www.HeavyEquipmentRestorationParts.com
www.FPTIndustrialEngineParts.com

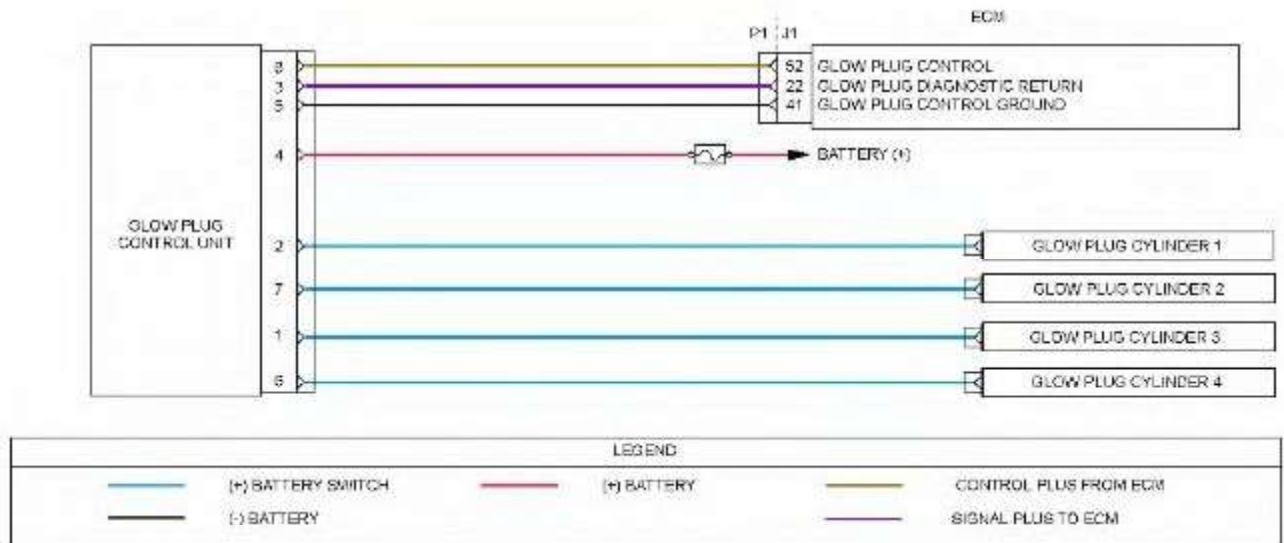

Illustration 1

g03770598

Schematic diagram for the glow plug starting aid circuit

Not all connectors are shown. Refer to the Electrical Schematic for the application.

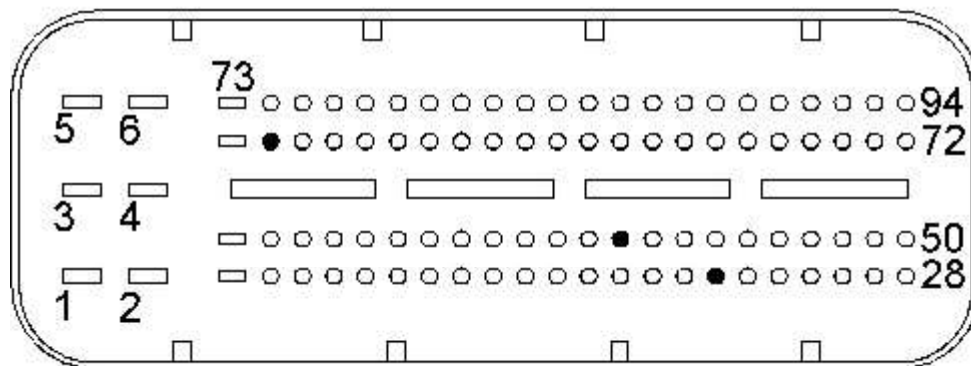

Illustration 2

g02671559

View of the pin locations on the P1 connector for the Glow Plug Control unit (GCU)

(22) GCU diagnostic return

(52) GCU control signal

(41) GCU ground

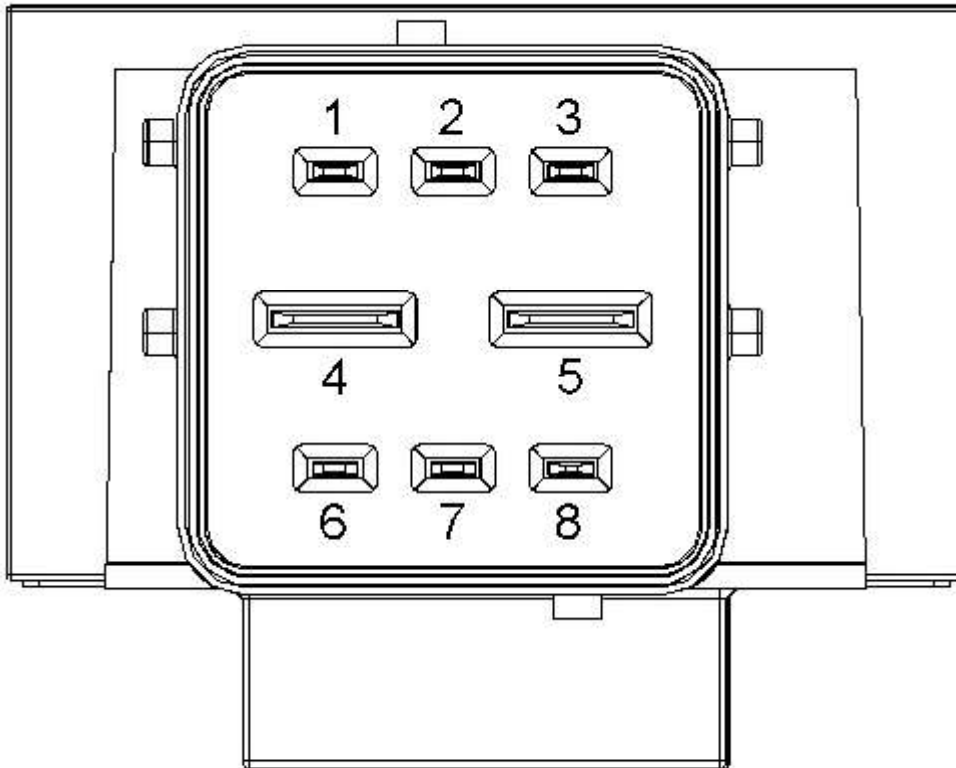

Illustration 3

g02674096

View of the pin locations on the GCU

- (1) Glow plug cylinder 3
- (2) Glow plug cylinder 1
- (3) GCU diagnostic return
- (4) Battery +
- (5) GCU ground
- (6) Glow plug cylinder 4
- (7) Glow plug cylinder 2
- (8) Glow plug control

Glow Plug Starting Aid Override

Activate this override using the electronic service tool. This override is used to check that the glow plugs are functioning correctly. The override will remain active until switched off using the electronic service tool.

Navigate to the following menu options in the electronic service tool to access the "Glow Plug Starting Aid Override":

- Diagnostics
- Diagnostic Tests

- Override Parameters

Table 2

Troubleshooting Test Steps	Values	Results
<p>1. Inspect Electrical Connectors and Wiring</p> <p>A. Check the fuses.</p> <p>B. Inspect the terminals on the GCU. Refer to Troubleshooting, "Electrical Connector - Inspect" for details.</p> <p>C. Inspect the connectors between the GCU and the glow plugs.</p> <p>D. Inspect the terminals on the P1/J1 ECM connector and all other connectors associated with the glow plug circuit.</p> <p>E. Perform a 30 N (6.7 lb) pull test on each of the wires in the ECM connector that are associated with glow plug circuit.</p> <p>F. Check the harness for abrasion and for pinch points from the glow plugs to the GCU, and from the GCU to the ECM.</p>	<p>Damaged wire or connector</p>	<p>Result: A damaged wire or damaged connector was found. A fuse is blown.</p> <p>Repair: Repair the damaged wire or the damaged connector. Replace any blown fuses. Use the electronic service tool to clear all logged diagnostic codes. Verify that the repair eliminates the fault.</p> <p>Result: All connectors, pins, and sockets are correctly connected and/or inserted and the harness is free of corrosion, of abrasion or of pinch points.</p> <p>Proceed to Test Step 2.</p>
<p>2. Check for Active Diagnostic Codes or Logged Diagnostic Codes</p> <p>A. Connect the electronic service tool to the diagnostic connector.</p> <p>B. Turn the keyswitch to the ON position. Do not start the engine.</p> <p>C. Use the electronic service tool to override the glow plug start aid.</p> <p>D. Check for active diagnostic codes or recently logged diagnostic codes.</p>	<p>Diagnostic codes</p>	<p>Result: A 5324-7, 5325-7, 5326-7, or 5327-7 diagnostic code is active or recently logged.</p> <p>Proceed to Test Step 3.</p> <p>Result: A 676 diagnostic code is active or recently logged</p> <p>Proceed to Test Step 6.</p> <p>Result: An active diagnostic code or a recently logged diagnostic code was not displayed.</p> <p>Repair: To identify intermittent faults, refer to</p>

<p>E. Use the electronic service tool to turn off the glow plug start aid.</p> <p>F. Turn the keyswitch to the OFF position.</p>		<p>Troubleshooting, "Electrical Connector - Inspect".</p>
<p>3. Check the Glow Plug for the Suspect Cylinder</p> <p>A. Turn the keyswitch to the OFF position.</p> <p>B. Disconnect the connectors for the glow plugs in any suspect cylinders. Refer to Table 1 to identify which cylinders are suspect.</p> <p>C. Use a multimeter to measure the resistance between the suspect glow plug connector and a suitable engine ground.</p>	<p>Resistance</p>	<p>Result: The measurement indicates an open circuit between the glow plug and the ground point.</p> <p>The glow plug is faulty.</p> <p>Repair: Replace the suspect glow plug. Refer to Disassembly and Assembly, "Glow Plugs - Remove and Install".</p> <p>Use the electronic service tool to override the glow plug start aid and verify that the repair eliminates the fault. Clear all logged diagnostic codes.</p> <p>Result: The measurement indicates that there is a resistance between the glow plug and the ground point.</p> <p>The glow plug is OK. Proceed to Test Step 4.</p>
<p>4. Check the Glow Plug Wiring for an Open Circuit</p> <p>A. Turn the keyswitch to the OFF position.</p> <p>B. Disconnect the connectors for any suspect glow plugs. Disconnect the connector for the GCU.</p> <p>C. Use a multimeter to measure the resistance between the harness connector for the suspect glow plug and the appropriate terminal on the GCU connector.</p>	<p>Less than 5 Ohms</p>	<p>Result: At least one of the resistance measurements is greater than 5 Ohms.</p> <p>The fault is in the wiring between the suspect glow plug and the GCU.</p> <p>Repair: Check all wiring between the suspect glow plug and the GCU. Refer to the Electrical Schematic for the application. Make any necessary repairs.</p> <p>Result: All resistance measurements are less than 5 Ohms.</p> <p>Reconnect all connectors. Proceed to Test Step 5.</p>

<p>5. Check the Glow Plug Wiring for a Short Circuit</p> <p>A. Turn the keyswitch to the OFF position.</p> <p>B. Disconnect the connector for the suspect glow plug.</p> <p>C. Use a multimeter to measure the resistance between the harness connector for the suspect glow plug and engine ground.</p>	<p>Greater than 1 k Ohm</p>	<p>Result: The measured resistance is less than 1 k Ohm.</p> <p>There is a short to ground in the wiring for the suspect glow plug.</p> <p>Repair: Check the wiring between the suspect glow plug and the GCU. Refer to the Electrical Schematic for the application. Make any necessary repairs.</p> <p>Result: The measured resistance is greater than 1 k Ohm.</p> <p>The wiring is OK.</p> <p>Repair: Install a replacement GCU. Use the electronic service tool to override the glow plug start aid and verify that the repair eliminates the fault.</p>
<p>6. Check that the GCU is Receiving the Correct Voltage</p> <p>A. Turn the keyswitch to the OFF position.</p> <p>B. Disconnect the GCU.</p> <p>C. Turn the keyswitch to the ON position.</p> <p>D. Measure the voltage between pin 4 on the harness connector for the GCU and a suitable ground.</p>	<p>10 V to 14 V</p>	<p>Result: The measured voltage is not within the expected range.</p> <p>Repair: Check the fuse for the GCU. If the fuse is blown, replace the fuse. If the fuse is replaced and the fault reoccurs, there is a short in the wiring between the battery supply and pin 4 on the GCU. If the fuse is not blown, there is an open circuit in the wiring between the battery supply and pin 4 on the GCU. Repair the faulty wiring or replace the faulty wiring. Reconnect the GCU. Use the electronic service tool to override the glow plug start aid and verify that the repair eliminates the fault. Clear all logged diagnostic codes.</p> <p>Result: The measured voltage is within the expected range.</p> <p>Proceed to Test Step 7.</p>
<p>7. Check That the GCU is Grounded Correctly</p>	<p>10 V to 14 V</p>	<p>Result: The measured voltage is not within the expected range.</p>

<p>A. Turn the keyswitch to the OFF position.</p> <p>B. Disconnect the GCU.</p> <p>C. Turn the keyswitch to the ON position.</p> <p>D. Measure the voltage between pin 4 and pin 5 on the harness connector for the GCU.</p>		<p>The fault is in the wiring between pin 5 on the harness connector for the GCU and P1:41.</p> <p>Repair: Inspect the 9-pin engine interface connector. Repair the faulty wiring or replace the faulty wiring. Use the electronic service tool to override the glow plug start aid and verify that the repair eliminates the fault.</p> <p>Clear all logged diagnostic codes.</p> <p>Result: The measured voltage is within the expected range.</p> <p>Proceed to Test Step 8.</p>
<p>8. Check the Type of Active Diagnostic Code</p> <p>A. Turn the keyswitch to the ON position.</p> <p>B. Use the electronic service tool to override the glow plug starting aid.</p> <p>C. Check for active diagnostic codes.</p> <p>D. Use the electronic service tool to turn off the glow plug starting aid.</p> <p>E. Turn the keyswitch to the OFF position.</p>	<p>Diagnostic Codes</p>	<p>Result: A 676-5 diagnostic code is active</p> <p>Proceed to Test Step 9.</p> <p>Result: A 676-6 diagnostic code is active</p> <p>Proceed to Test Step 11.</p> <p>Result: A 676-19 diagnostic code is active</p> <p>Proceed to Test Step 12.</p>
<p>9. Check the GCU Wiring for an Open Circuit</p> <p>A. Turn the keyswitch to the OFF position.</p> <p>B. Disconnect the GCU.</p> <p>C. Disconnect the P1 connector from the ECM.</p> <p>D. Use a multimeter to measure the resistance between the following points:</p>	<p>Less than 5 Ohms</p>	<p>Result: The measured resistance is not within the expected range.</p> <p>There is an open circuit or high resistance in the wiring between the GCU and the P1 connector. Inspect the 9-pin engine interface connector (if equipped). Repair the faulty wiring or replace the faulty wiring.</p> <p>Result: The measured resistance is within the expected range.</p> <p>Proceed to Test Step 10.</p>

<ul style="list-style-type: none"> • Terminal 8 on the GCU harness connector and P1:52 • Terminal 5 on the GCU harness connector and P1:41 		
<p>10. Check the GCU Wiring for a Short to Ground</p> <p>A. Turn the keyswitch to the OFF position.</p> <p>B. Disconnect the GCU.</p> <p>C. Disconnect the P1 connector from the ECM.</p> <p>D. Use a multimeter to measure the resistance between the following terminals and a suitable engine ground:</p> <ul style="list-style-type: none"> • Terminal 8 on the GCU harness connector • Terminal 3 on the GCU harness connector • Terminal 5 on the GCU harness connector 	<p>Greater than 1 k Ohm</p>	<p>Result: The measured resistance is not within the expected range.</p> <p>There is a short to ground in the wiring between the GCU and the P1 connector. Inspect the 9-pin engine interface connector (if equipped). Repair the faulty wiring or replace the faulty wiring.</p> <p>Result: The measured resistance is within the expected range.</p> <p>Repair: Install a replacement GCU. Use the electronic service tool to override the glow plug starting aid and verify that the repair eliminates the fault. Clear all logged diagnostic codes.</p> <p>If the repair does not eliminate the fault, contact the Dealer Solutions Network (DSN).</p>
<p>11. Check the GCU Wiring for a Short Circuit</p> <p>A. Turn the keyswitch to the OFF position.</p> <p>B. Disconnect the GCU.</p> <p>C. Disconnect the P1 connector from the ECM.</p> <p>D. Use a multimeter to measure the resistance between the following points:</p> <ul style="list-style-type: none"> • P1:52 and all other terminals on the P1 connector • P1:22 and all other terminals on the P1 connector • P1:41 and all other terminals on the 	<p>Greater than 1 k Ohm</p>	<p>Result: At least one of the resistance measurements is not within the expected range.</p> <p>There is a short in the wiring between the GCU connector and the P1 ECM connector. Inspect the 9-pin engine interface connector (if equipped). Repair the faulty wiring or replace the faulty wiring.</p> <p>Result: All resistance measurements are within the expected range.</p> <p>Repair: Install a replacement GCU. Use the electronic service tool to override the glow plug starting aid and verify that the repair eliminates the fault. Clear all logged diagnostic codes.</p> <p>If the repair does not eliminate the fault, contact the Dealer Solutions Network (DSN).</p>

P1 connector		
<p>12. Check the Diagnostic Return Wire From the GCU</p> <p>A. Turn the keyswitch to the OFF position.</p> <p>B. Disconnect the GCU. Disconnect the P1/J1 connector.</p> <p>C. Measure the resistance between pin 3 on the harness connector for the GCU and P1:22.</p>	Less than 5 Ohms	<p>Result: The measured resistance is greater than 5 Ohms.</p> <p>There is an open circuit or high resistance in the wiring.</p> <p>Repair: Repair the faulty wiring or replace the faulty wiring.</p> <p>Result: The measured resistance is less than 5 Ohms.</p> <p>Contact the Dealer Solution Network (DSN).</p>

CAT C3.4B Engine Parts
Contact phone: 269 673 1638
Email: EngineParts@HeavyEquipmentRestorationParts.com
Alternate email: engineparts2@gmail.com
Website: www.CATC34B.com
Related website: www.HeavyEquipmentRestorationParts.com
www.FPTIndustrialEngineParts.com



Previous Screen



Troubleshooting

C3.4B Engines

Media Number -UENR0611-10

Publication Date -01/02/2015

i06012069

Idle Validation - Test

SMCS - 7332-038

This procedure covers the following diagnostic codes.

Table 1

Diagnostic Trouble Codes		
J1939 Code	Code Description	Comments
558-2	Accelerator Pedal 1 Low Idle Switch : Erratic, Intermittent, or Incorrect	The Electronic Control Module (ECM) detects one of the following conditions: The signal voltage from the throttle pedal is less than 1.05 V for 0.3 seconds while the idle validation switch is not active.
2970-2	Accelerator Pedal 2 Low Idle Switch : Erratic, Intermittent, or Incorrect	The signal voltage from the throttle pedal is greater than 1.25 V for 0.3 seconds while the idle validation switch is active. The warning lamp will flash. The engine will be derated.
Follow the troubleshooting procedure in order to identify the root cause of the problem.		

If the application is equipped with two throttles, the engine will use the second throttle until the fault is repaired.

If a second throttle is not installed or if the second throttle has a fault, the following conditions will occur:

- The engine will default to limp home mode.
- If the engine speed is higher than the speed in limp home mode, the engine will decelerate to limp home mode.

- If the engine speed is lower than the speed in limp home mode, the engine speed will remain at the current speed.
- The engine will remain at this speed while the diagnostic code remains active.
- All inputs from the faulty throttle are ignored by the ECM until the fault is repaired.
- All inputs from the repaired throttle will be ignored by the ECM until the keyswitch has been cycled.

The IVS may be installed. The IVS is required for mobile applications. The IVS is part of the throttle position sensor. The IVS is CLOSED when the low idle is set.

The configuration parameters for the throttle and for the IVS thresholds are programmed into the ECM. Use the electronic service tool in order to display the configuration parameters for the throttle and for the IVS.

If the IVS operates outside of the programmed range, then the engine speed may not respond to changes in the throttle position.

The electronic service tool may be used for the following:

- If necessary, reset the IVS threshold for an existing IVS.
- If necessary, view the IVS change point and reset the IVS thresholds when a new throttle assembly is installed.

CAT C3.4B Engine Parts
Contact phone: 269 673 1638
Email: EngineParts@HeavyEquipmentRestorationParts.com
Alternate email: engineparts2@gmail.com
Website: www.CATC34B.com
Related website: www.HeavyEquipmentRestorationParts.com

www.FPTIndustrialEngineParts.com

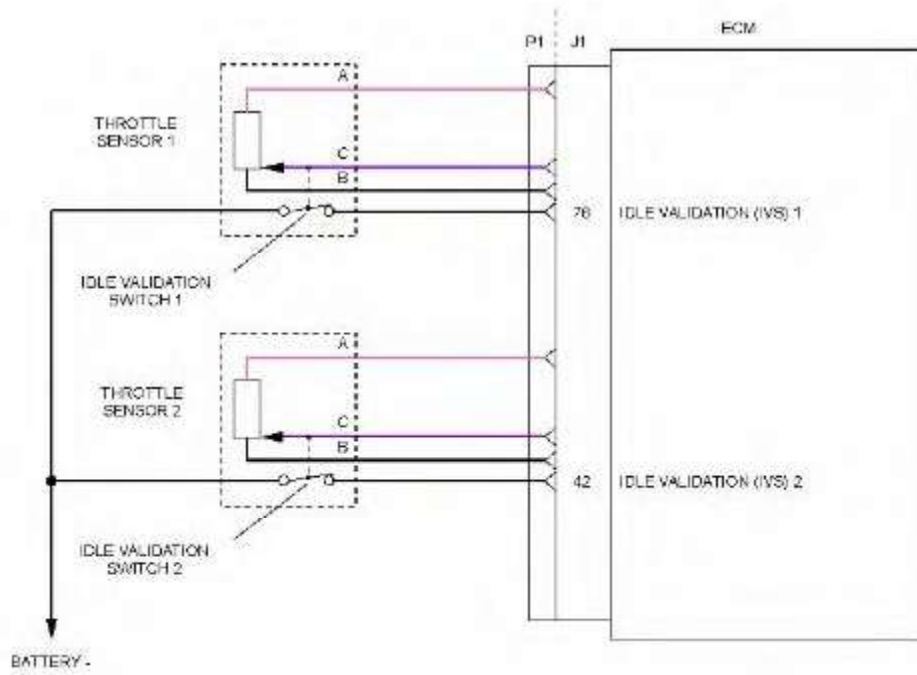

LEGEND			
	SENSOR SUPPLY		SIGNAL PLUS TO ECM
	SENSOR RETURN		

Illustration 1

g03771038

Schematic diagram for the Idle Validation Switch (IVS) switch circuit

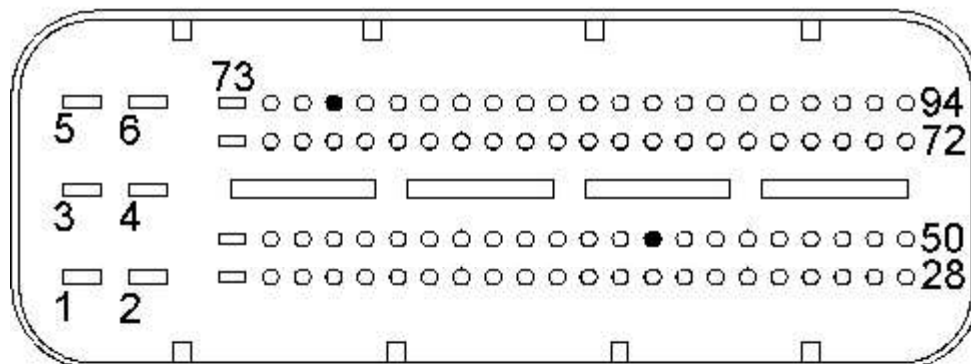

Illustration 2

g03771057

View of the pin locations on the P1 connector for the IVS circuit
 (42) IVS 2
 (76) IVS 1

Table 2

Troubleshooting Test Steps	Values	Results
<p>1. Check for Active Diagnostic Codes</p> <p>A. Establish communication between the electronic service tool and the ECM. Refer to Troubleshooting, "Electronic Service Tools"</p> <p>B. Check for active or logged codes.</p>	<p>Diagnostic Trouble Codes</p>	<p>Result: There is an active or logged , 558-2 or 2970-2 diagnostic code.</p> <p>Proceed to Test Step 2.</p>
<p>2. Check the Operation of the IVS</p> <p>A. Turn the keyswitch to the OFF position.</p> <p>B. Connect the electronic service tool to the diagnostic connector.</p> <p>C. Turn the keyswitch to the ON position.</p> <p>D. Use the electronic service tool in order to check the current "Throttle Configuration".</p> <p>E. Select the "SERVICE" option from the drop-down menu of the electronic service tool.</p> <p>F. Select the "Throttle Configuration" option on the electronic service tool. Select the appropriate "Throttle Configuration" summary from the menu on the left of the screen. The IVS window for the throttle will indicate "YES" if an IVS is installed.</p> <p>G. Select the "Throttle status" function on the electronic service tool. Select "Status" function and then select "Throttles" function.</p> <p>H. The throttle is set in the low idle position.</p> <p>I. Operate the throttle slowly. The IVS status should change from CLOSED (ON) to OPEN</p>	<p>Switch state</p>	<p>Result: The IVS state changes from CLOSED (ON) to OPEN (OFF).</p> <p>Proceed to Test Step 3.</p> <p>Result: The IVS does not operate</p> <p>Proceed to Test Step 4.</p>

(OFF).		
<p>3. Check the IVS Threshold</p> <p>A. Connect the electronic service tool to the diagnostic connector.</p> <p>B. Turn the keyswitch to the ON position.</p> <p>C. Use the electronic service tool in order to check the current "Throttle Configuration".</p> <p>D. Select the "SERVICE" option from the drop-down menu of the electronic service tool.</p> <p>E. Select the "Throttle Configuration" option on the electronic service tool. Select the appropriate "Throttle Configuration" summary from the menu on the left of the screen. The IVS window for the throttle will indicate "YES" if an IVS is installed. Make a note of the "Idle Validation Min OFF Threshold" parameters that are displayed in the "Throttle Configuration" menu of the electronic service tool. Make a note of the "Idle Validation Max ON Threshold" parameters that are displayed in the "Throttle Configuration" menu of the electronic service tool.</p> <p>F. To select the "Throttle status" function on the electronic service tool, select "Status" function and then select "Throttles" function.</p> <p>G. The throttle is set in the low idle position.</p> <p>H. Operate the throttle slowly. The IVS status should change from CLOSED (ON) to OPEN (OFF).</p>	<p>Switch operation</p>	<p>Result: The IVS switch operates within the "Idle Validation Min OFF Threshold" and the "Idle Validation Max ON Threshold" parameters.</p> <p>The fault appears to be resolved. Return the engine to service.</p> <p>Result: The IVS switch cannot operate within the "Idle Validation Min OFF Threshold" and the "Idle Validation Max ON Threshold" parameters</p> <p>Proceed to Test Step 10.</p>
<p>4. Inspect Electrical Connectors and Wiring</p> <p>A. Inspect the P1/J1 ECM connector.</p> <p>B. Inspect the connectors for the throttle position sensors.</p> <p>C. Perform a 30 N (6.7 lb) pull test on each of the</p>	<p>Damaged wire or connector</p>	<p>Result: A damaged wire or damaged connector was not found.</p> <p>Proceed to Test Step 5.</p> <p>Result: A damaged wire or damaged connector was</p>

<p>wires in the ECM connector and the connector for the throttle position sensors.</p> <p>D. Check all of the wiring associated with the throttle position sensors for abrasions and pinch points.</p>		<p>found.</p> <p>Repair the damaged wire or the damaged connector. Use the electronic service tool to clear all logged diagnostic codes. Verify that the repair eliminates the fault.</p>
<p>5. Check the Voltage at the IVS Switch</p> <p>A. Disconnect the IVS harness connector.</p> <p>B. Turn the keyswitch to the ON position.</p> <p>C. Use a suitable multimeter to measure the voltage between the IVS terminal on the harness connector and a suitable ground.</p> <p>D. Turn the keyswitch to the OFF position.</p>	<p>7.9 V to 12.2 V</p>	<p>Result: The voltage is within the expected range.</p> <p>Proceed to Test Step 6.</p> <p>Result: The voltage is not within the expected range.</p> <p>Proceed to Test Step 7.</p>
<p>6. Check that the IVS is Grounded</p> <p>A. Disconnect the IVS harness connector.</p> <p>B. Turn the keyswitch to the ON position.</p> <p>C. Use a suitable multimeter to measure the voltage between the IVS terminal on the harness connector the ground terminal on the harness connector.</p> <p>D. Turn the keyswitch to the OFF position.</p>	<p>7.9 V to 12.2 V</p>	<p>Result: The voltage is within the expected range.</p> <p>Proceed to Test Step 9.</p> <p>Result: The voltage is not within the expected range. The fault is in the ground wire for the suspect IVS.</p> <p>Replace the faulty wiring. Refer to the OEM for more information on the wiring for the IVS. Use the electronic service tool to clear all logged diagnostic codes and verify that the repair eliminates the fault.</p>
<p>7. Check the Application Harness for an Open Circuit</p>	<p>Less than 5 Ohms</p>	<p>Result: The measured resistance is less than 5</p>

<p>A. Turn the keyswitch to the OFF position.</p> <p>B. Disconnect the connector for the suspect IVS. Disconnect the P1 connector.</p> <p>C. If the IVS 1 is suspect, use a suitable multimeter to measure the resistance between the IVS terminal on the harness connector to P1:76. If the IVS 2 is suspect, use a suitable multimeter to measure the resistance between the IVS terminal on the harness connector to P1:42.</p>		<p>Ohms.</p> <p>Proceed to Test Step 8.</p> <p>Result: The measured resistance is greater than 5 Ohms.</p> <p>There is an open circuit or high resistance in the wiring between the IVS and the ECM.</p> <p>Replace the faulty wiring. Use the electronic service tool to clear all logged diagnostic codes and verify that the repair eliminates the fault.</p>
<p>8. Check the Application Harness for a Short Circuit</p> <p>A. Turn the keyswitch to the OFF position.</p> <p>B. Disconnect the suspect IVS connector. Disconnect the P1 connector.</p> <p>C. If the IVS 1 is suspect, use a suitable multimeter to measure the resistance between P1:76 and all other terminals on the P1 connector. If the IVS 2 is suspect, use a suitable multimeter to measure the resistance between P1:42 and all other terminals on the P1 connector.</p>	<p>Greater than 1 k Ohm</p>	<p>Result: All resistance measurements are greater than 1 k Ohm.</p> <p>Contact the Dealer Solution Network (DSN).</p> <p>Result: At least one of the measured resistances is less than 1 k Ohm.</p> <p>There is a short in the wiring between the connector for the suspect IVS and the P1 connector. Replace the faulty wiring. Use the electronic service tool to clear all logged diagnostic codes and verify that the repair eliminates the fault.</p>
<p>9. Check the IVS at the Sensor</p> <p>A. Turn the keyswitch to the OFF position.</p> <p>B. Disconnect the IVS.</p>	<p>Less than 10 Ohms at low idle.</p> <p>Greater than 2000 Ohms at high idle.</p>	<p>Result: The IVS indicates the expected resistance.</p> <p>No fault is indicated at this time. Recheck the harness</p>

<p>C. Set the throttle to low idle.</p> <p>D. Check the resistance of the IVS.</p> <p>E. Set the throttle to high idle.</p> <p>F. Check the resistance of the IVS.</p>		<p>for intermittent connections.</p> <p>Result: At least one of the resistance measurements is outside of the expected range.</p> <p>Replace the IVS or replace the throttle sensor. Refer to OEM documentation for information on the throttle sensor.</p> <p>Proceed to Test Step 10.</p>
<p>10. Check the IVS Calibration</p> <p>A. Connect the electronic service tool to the diagnostic connector.</p> <p>B. Turn the keyswitch to the ON position.</p> <p>C. Select the "Throttle Configuration" option on the electronic service tool. Select the appropriate "Throttle Configuration" summary from the menu on the left of the screen. The IVS window for the throttle will indicate "YES" if an IVS is installed. Make a note of the "Idle Validation Min OFF Threshold" parameters that are displayed in the "Throttle Configuration" menu of the electronic service tool. Make a note of the "Idle Validation Max ON Threshold" parameters that are displayed in the "Throttle Configuration" menu of the electronic service tool.</p> <p>D. Select the "Throttle status" function on the electronic service tool. Select "Status" function and then select "Throttles" function.</p> <p>E. Set the throttle to low idle.</p> <p>F. Operate the throttle slowly toward high idle. The raw percentage values for the throttle that are shown on the electronic service tool should increase and the IVS status should change from CLOSED (ON) to OPEN (OFF) position. Make a note of the raw reading for the throttle when the</p>	<p>The IVS operates within the "Idle Validation Min OFF Threshold" and the "Idle Validation Max ON Threshold" values that are shown on the "Configuration" menu of the electronic service tool.</p>	<p>Result: The IVS operates within the "Idle Validation Min OFF Threshold" and the "Idle Validation Max ON Threshold" values that are shown on the "Configuration" menu of the electronic service tool.</p> <p>Return the engine to service.</p> <p>Result: The IVS does not operate within the "Idle Validation Min OFF Threshold" and the "Idle Validation Max ON Threshold" values that are shown on the "Configuration" menu of the electronic service tool.</p> <p>Proceed to Test Step 11.</p>

<p>IVS reading changes from the CLOSED position to the OPEN position. Repeat this step in order to obtain accurate raw percentage values for the throttle. The noted value should be within the previously noted "Idle Validation Min OFF Threshold" and "Idle Validation Max ON Threshold" limits.</p> <p>G. The throttle is set to the full throttle position or the high idle position.</p> <p>H. Operate the throttle slowly toward low idle. The raw percentage values for the throttle that are shown on the electronic service tool should decrease and the IVS status should change from OPEN (OFF) to CLOSED (ON) position. Make a note of the raw reading for the throttle when the IVS reading changes from the OPEN position to the CLOSED position. Repeat this step in order to obtain accurate raw percentage values for the throttle. The noted value should be within the previously noted "Idle Validation Min OFF Threshold" and "Idle Validation Max ON Threshold" limits.</p>		
<p>11. Use the Electronic Service Tool to Reset the IVS Threshold Limits</p> <p>The electronic service tool can be used to change the "Idle Validation Min OFF Threshold" and the "Idle Validation Max ON Threshold" in order to suit the type of throttle that is installed. The limits are shown in the "Throttle Configuration" screen which is located in the "Service" menu.</p> <p>A. Refer to Test Step 8 and record the raw value of the throttle signal when the idle validation switch changes from the CLOSED position to the OPEN position. Note: The default value for the "Idle Validation Min OFF Threshold" is 21%. The lowest value that should be set is 5%. The default value for the "Idle Validation Max ON Threshold" is 25%. The maximum value that is expected is 28%.</p> <p>B. Set the "Idle Validation Min OFF Threshold" to 3% below the raw value that was previously</p>	<p>Fault cleared</p>	<p>Result: The fault is cleared after programming the new calculated values.</p> <p>Return the engine to service.</p> <p>Result: The fault is not cleared.</p> <p>Contact the Dealer Solution Network (DSN).</p>

recorded.

C. Set the "Idle Validation Max ON Threshold" to 3% above the raw value.

D. Enter the new threshold limits into the electronic service tool. Click "Submit" on the electronic service tool screen.

E. Turn the keyswitch to the OFF position and wait at least 5 seconds. Turn the keyswitch to the ON position.

F. Repeat Test Step 8. Check that the IVS operates within the newly set threshold limits.

Complete the procedure in the order in which the steps are listed.

If the procedure did not correct the issue, Contact the Dealer Solution Network (DSN).

CAT C3.4B Engine Parts

Contact phone: 269 673 1638

Email: EngineParts@HeavyEquipmentRestorationParts.com

Alternate email: engineparts2@gmail.com

Website: www.CATC34B.com

Related website: www.HeavyEquipmentRestorationParts.com

www.FPTIndustrialEngineParts.com



Previous Screen



Troubleshooting

C3.4B Engines

Media Number -UENR0611-10

Publication Date -01/02/2015

i06013882

Indicator Lamp - Test

SMCS - 7431-038

Use this procedure under the following circumstances:

- The lamps are not receiving battery voltage.
- The lamps are not operating correctly.
- One of the following diagnostic codes is active:

Table 1

Diagnostic Trouble Codes for the Indicator Lamps		
J1939 Code	Description	Notes
623-5	Red Stop Lamp : Current Below Normal	The Electronic Control Module (ECM) detects a low current condition in the circuit for the shutdown lamp.
623-6	Red Stop Lamp : Current Above Normal	The ECM detects a high current condition in the circuit for the shutdown lamp.
624-5	Amber Warning Lamp : Current Below Normal	The ECM detects a low current condition in the circuit for the warning lamp.
624-6	Amber Warning Lamp : Current Above Normal	The ECM detects a high current condition in the circuit for the warning lamp.
1081-5	Engine Wait to Start Lamp : Current Below Normal	The ECM detects a low current condition in the circuit for the wait to start lamp.
1081-6		

	Engine Wait to Start Lamp : Current Above Normal	The ECM detects a high current condition in the circuit for the wait to start lamp.
3697-5	Particulate Trap Lamp Command : Current Below Normal	The ECM detects a low current condition in the circuit for the Diesel Particulate Filter (DPF) lamp.
3697-6	Particulate Trap Lamp Command : Current Above Normal	The ECM detects a high current condition in the circuit for the DPF lamp.
3698-5	Exhaust System High Temperature Lamp Command : Current Below Normal	The ECM detects a low current condition in the circuit for the High Exhaust System Temperature (HEST) lamp.
3698-6	Exhaust System High Temperature Lamp Command : Current Above Normal	The ECM detects a high current condition in the circuit for the HEST lamp.
3702-5	Diesel Particulate Filter Active Regeneration Inhibited Status : Current Below Normal	The ECM detects a low current condition in the circuit for the DPF disabled lamp.
3702-6	Diesel Particulate Filter Active Regeneration Inhibited Status : Current Above Normal	The ECM detects a high current condition in the circuit for the DPF disabled lamp.
5099-5	Engine Oil Pressure Low Lamp Data : Current Below Normal	The ECM detects a low current condition in the circuit for the low oil pressure lamp.
5099-6	Engine Oil Pressure Low Lamp Data : Current Above Normal	The ECM detects a high current condition in the circuit for the low oil pressure lamp.

The Engine Control Module (ECM) provides nine outputs that can be used to illuminate indicator lamps. If applicable, some of the outputs can be programmed to a J1939 device.

Each J1/P1 output is a low side driver.

Low Side Driver - The ECM provides a connection to ground in order to activate the lamp.

J1939 Device - The ECM sends digital data on the J1939 data link in order to control the lamp.

Table 2 provides information on the typical lamp outputs.

Table 2

Lamp Outputs (Typical Application)	
Lamp	Default Output Terminal
Regeneration Active Lamp	J1/P1:74
Shutdown Lamp	J1/P1:51
Warning Lamp	J1/P1:92
Wait to Start Lamp	J1/P1:50

Low Oil Pressure Lamp	J1/P1:69
Diesel Particulate Filter (DPF) Lamp	J1/P1:94
DPF Disabled Lamp	J1/P1:48

Testing the Circuits

The ECM briefly activates the lamps when the keyswitch is turned from OFF to ON.

Table 3

Troubleshooting Test Steps	Values	Results
<p>1. Test the Circuit</p> <p>A. Turn the keyswitch from OFF to ON in order to test the circuit. Watch the lamp during the test.</p>	Circuit test	<p>Result: The lamp does not illuminate.</p> <p>Troubleshoot any active codes before continuing with this procedure.</p> <p>Proceed to Test Step 2.</p> <p>Result: The lamp illuminates.</p> <p>There is a problem with the wiring if the problem is intermittent. Troubleshoot the wiring by referring to the electrical schematic for the application.</p> <p>STOP</p>
<p>2. Check the Bulb</p> <p>Replace the bulb with a bulb that is known to be good. Test the circuit again.</p>	Bulb	<p>Result: The lamp illuminates. The problem is resolved.</p> <p>STOP</p> <p>Result: The lamp does not illuminate. The bulb is OK.</p> <p>The +Battery or the ground is not present at the lamp. Refer to the electrical schematic. Troubleshoot the wiring by referring to the electrical schematic if the lamp output is programmed to a J1939 device.</p> <p>Proceed to Test Step 3 if the lamp output is programmed to a J1/P1 terminal..</p>

3. Troubleshoot the Wiring for the Lamp

Check the wiring for an open circuit. Pay particular attention to possible problems with electrical connectors.

Lamp wiring

Result: There is an open circuit in the wiring for the lamp.

Make the necessary repairs.

STOP

Result: The wiring for the lamp is OK.

Contact the Dealer Solution Network (DSN).

[Previous Screen](#)

Troubleshooting

C3.4B Engines

Media Number -UENR0611-10

Publication Date -01/02/2015

i05867872

Injector Code - Calibrate

SMCS - 1290-524

Injector codes are seven digit alphanumerical codes that are supplied with each injector. The code is printed on the injector . The code is used by the Electronic Control Module (ECM) to balance the performance of the injectors.

The electronic service tool is used to load the injector codes into the ECM.

The injector codes must be loaded into the ECM if any of the following conditions occur:

- An electronic unit injector is replaced.
- The ECM is replaced.
- Electronic unit injectors are exchanged between cylinders.
- A 630-2 diagnostic code is active.

If the ECM is replaced, the injector codes are normally transferred to the new ECM as part of the "Copy Configuration" procedure. If the "Copy Configuration" procedure fails, the injector codes must be loaded manually.

Installing Injector Codes

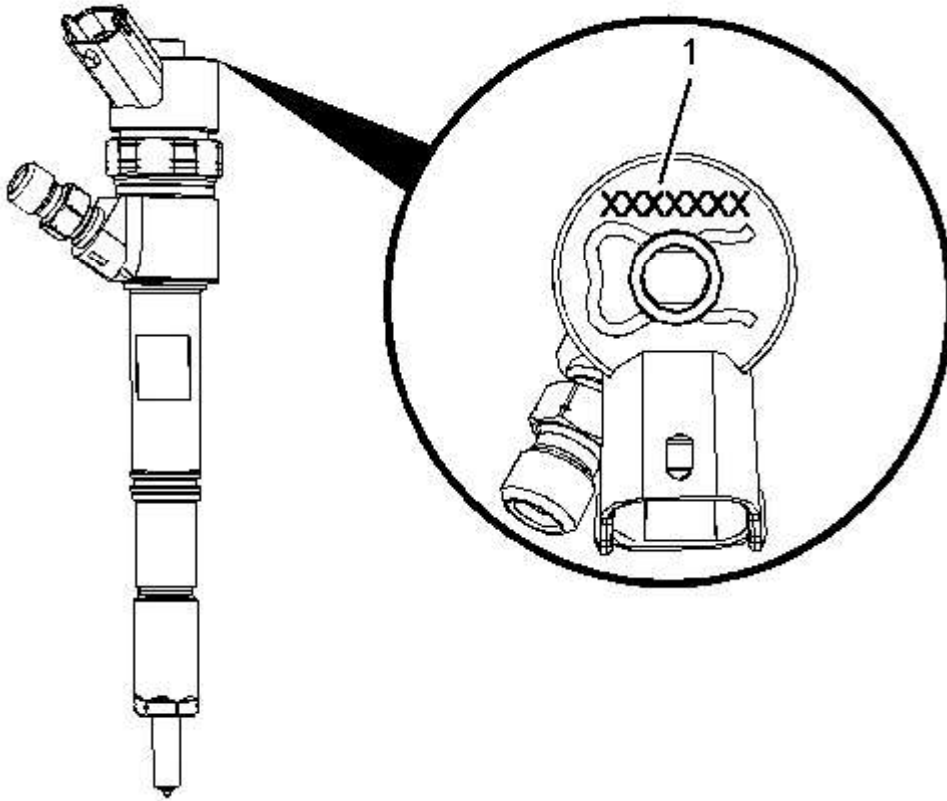

Illustration 1

g02738616

Typical example of an electronic unit injector

(1) Location of the injector code

1. Record the injector code for each electronic unit injector.
2. Connect the electronic service tool to the diagnostic connector. Refer to Troubleshooting, "Electronic Service Tools".
3. Turn the keyswitch to the ON position.
4. Select the following menu options on the electronic service tool:
 - Service
 - Calibrations
 - Injector Trim Calibration
5. Select the appropriate cylinder.
6. Click on the "Change" button.
7. Input the applicable injector code that was recorded in Test Step 1.

8. Click on the "OK" button.

The injector code is loaded into the ECM.

9. Repeat the procedure for each cylinder, as required.

Exchanging Electronic Unit Injectors

Exchanging electronic unit injectors can help determine if a combustion problem is in the electronic unit injector or in the cylinder. If two electronic unit injectors that are currently installed in the engine are exchanged between cylinders, the injector codes must also be exchanged. Record the injector trim codes for the two injectors that are to be exchanged. Use the electronic service tool to enter the injector codes for the correct cylinders.

CAT C3.4B Engine Parts

Contact phone: 269 673 1638

Email: EngineParts@HeavyEquipmentRestorationParts.com

Alternate email: engineparts2@gmail.com

Website: www.CATC34B.com

Related website: www.HeavyEquipmentRestorationParts.com

www.FPTIndustrialEngineParts.com



Previous Screen



Troubleshooting

C3.4B Engines

Media Number -UENR0611-10

Publication Date -01/02/2015

i06014480

Injector Data Incorrect - Test

SMCS - 1290-038

This procedure covers the following codes:

Table 1

Diagnostic Trouble Codes for "Injector Data Incorrect"		
J1939 Code	Description	Notes
630-2	Calibration Memory : Erratic, Intermittent, or Incorrect	The Electronic Control Module (ECM) detects one of the following conditions. An injector code has not been programmed for one or more of the injectors. OR The injector code for one or more of the injectors is invalid. The engine may have rough running at low idle.
651-20	Engine Injector Cylinder #01 : Data Drifted High	The ECM will calibrate the injector energizing times while the engine is at low idle based on the readings from the oxygen sensor. If the calculated energizing times exceed the limits set by the injector code, one of these diagnostic codes will become active for the applicable cylinder.
651-21	Engine Injector Cylinder #01 : Data Drifted Low	
652-20	Engine Injector Cylinder #02 : Data Drifted High	
652-21	Engine Injector Cylinder #02 : Data Drifted Low	
653-20		

	Engine Injector Cylinder #03 : Data Drifted High
653-21	Engine Injector Cylinder #03 : Data Drifted Low
654-20	Engine Injector Cylinder #04 : Data Drifted High
654-21	Engine Injector Cylinder #04 : Data Drifted Low

The following background information is related to this procedure:

Injector codes are seven digit alphanumeric codes that are supplied with each injector. The code is printed on each injector. The code is used by the ECM to balance the performance of the injectors.

Refer to Troubleshooting, "Injector Code - Calibrate" for further information.

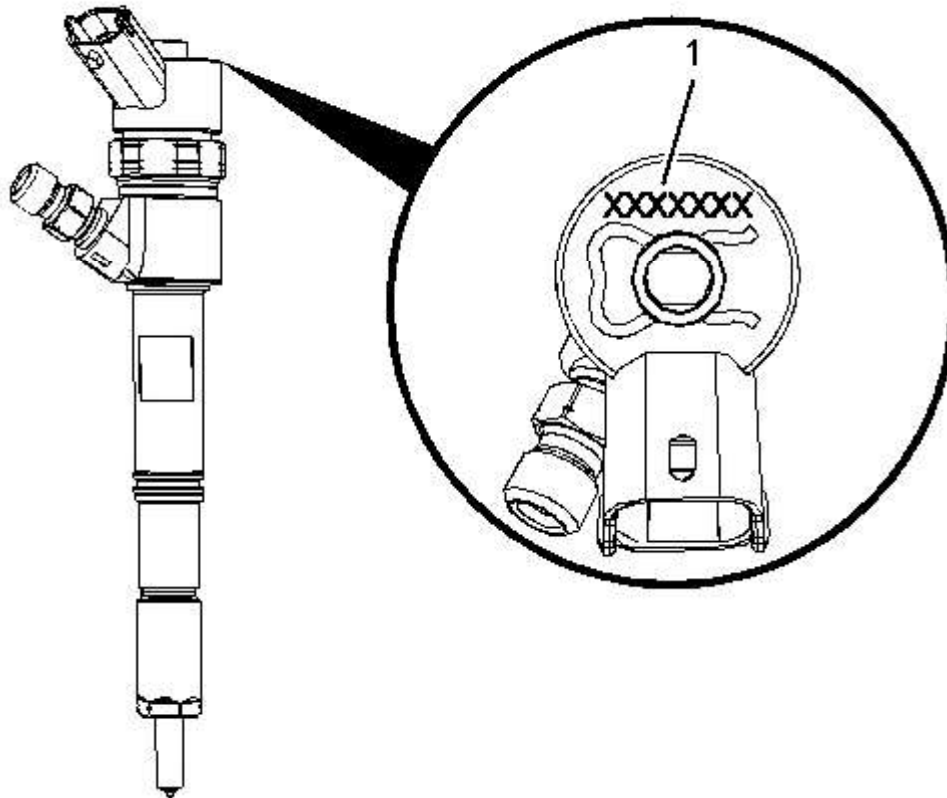

Illustration 1

g02738616

Typical example of an electronic unit injector
 (1) Location of the injector code

Table 2

Troubleshooting Test Steps	Values	Results
<p>1. Check for Diagnostic Codes That Are Related to this Procedure</p> <p>A. Connect the electronic service tool to the diagnostic connector.</p> <p>B. Turn the keyswitch to the ON position.</p> <p>C. Check for any active diagnostic codes that are listed in Table 1.</p> <p>D. Make a note of the active diagnostic codes.</p>	Diagnostic codes	<p>Result: A 630-2 diagnostic code is active.</p> <p>Proceed to Test Step 2.</p> <p>Result: An XXX-20 or XXX-21 diagnostic code is active.</p> <p>Proceed to Test Step 4.</p>
<p>2. Enter the Injector Codes Using the Electronic Service Tool</p> <p>A. Connect the electronic service tool to the diagnostic connector. Refer to Troubleshooting, "Electronic Service Tools".</p> <p>B. Turn the keyswitch to the ON position.</p> <p>C. Manually enter the injector codes using the electronic service tool. Refer to Troubleshooting, "Injector Code - Calibrate".</p> <p>D. Use the electronic service tool to clear all active diagnostic codes.</p> <p>E. Start the engine.</p> <p>F. Use the electronic service tool to check for active diagnostic codes.</p> <p>G. Turn the keyswitch to the OFF position.</p>	Diagnostic codes	<p>Result: The 630-2 diagnostic code is no longer active.</p> <p>Return the engine to service.</p> <p>Result: The 630-2 diagnostic code is still active.</p> <p>Proceed to Test Step 3.</p>
<p>3. Re-Flash the ECM</p> <p>A. Reflash the ECM. Refer to Troubleshooting, "ECM Software - Install".</p>	Diagnostic codes	<p>Result: The 630-2 diagnostic code is no longer active.</p> <p>Return the engine to service.</p>

<p>B. Ensure that all of the injector codes are programmed. Refer to Troubleshooting, "Injector Code - Calibrate".</p> <p>C. Use the electronic service tool to clear all active diagnostic codes.</p> <p>D. Start the engine.</p> <p>E. Use the electronic service tool to check for active diagnostic codes.</p>		<p>Result: The 630-2 diagnostic code is still active</p> <p>Proceed to Test Step 7.</p>
<p>4. Check the Oxygen Sensor for Faults</p> <p>A. Connect the electronic service tool to the diagnostic connector.</p> <p>B. Turn the keyswitch to the ON position.</p> <p>C. Check for active or recently logged diagnostic codes for the oxygen sensor.</p>	<p>10 V to 14 V</p>	<p>Result: There are no diagnostic codes for the oxygen sensor.</p> <p>Proceed to Test Step 5.</p> <p>Result: There are diagnostic codes for the oxygen sensor</p> <p>Troubleshoot the oxygen sensor before returning to this procedure. Refer to Troubleshooting, "Oxygen Level - Test".</p>
<p>5. Enter the Injector Code for the Suspect Cylinder</p> <p>A. Connect the electronic service tool to the diagnostic connector. Refer to Troubleshooting, "Electronic Service Tools".</p> <p>B. Turn the keyswitch to the ON position.</p> <p>C. Manually enter the injector code for the suspect cylinder using the electronic service tool. Refer to Troubleshooting, "Injector Code - Calibrate".</p> <p>D. Use the electronic service tool to clear all active diagnostic codes.</p> <p>E. Start the engine.</p> <p>F. Use the electronic service tool to check for active diagnostic codes.</p>	<p>Diagnostic codes</p>	<p>Result: There are no active XXX-20 or XXX-21 diagnostic codes for the injectors.</p> <p>Return the engine to service.</p> <p>Result: The XXX-20 or XXX-21 diagnostic code is still active.</p> <p>Proceed to Test Step 6.</p>

G. Turn the keyswitch to the OFF position.		
<p>6. Replace the Suspect Injector</p> <p>A. Replace the injector for the cylinder with the XXX-20 or XXX-21 diagnostic code. Refer to Disassembly and Assembly, "Electronic Unit Injector - Remove" and refer to Disassembly and Assembly, "Electronic Unit Injector - Install".</p> <p>B. Use the electronic service tool to input the code for the new injector. Refer to Troubleshooting, "Injector Code - Calibrate".</p> <p>C. Use the electronic service tool to check for active diagnostic codes.</p>	Diagnostic Codes	<p>Result: There are no active XXX-20 or XXX-21 diagnostic codes for the injectors.</p> <p>Return the engine to service.</p> <p>Result: The XXX-20 or XXX-21 diagnostic code is still active.</p> <p>Proceed to Test Step 7.</p>
<p>7. Check if a Replacement ECM Eliminates the Fault</p> <p>A. Contact the Dealer Solution Network (DSN).</p> <p>B. If the DSN recommends the use of a replacement ECM, install a replacement ECM. Refer to Troubleshooting, "Replacing the ECM".</p> <p>C. Use the electronic service tool to recheck the system for active diagnostic codes.</p>	Diagnostic codes	<p>Result: There are no active diagnostic codes with the replacement ECM.</p> <p>Reconnect the suspect ECM. If the fault returns with the suspect ECM, replace the ECM.</p> <p>Use the electronic service tool in order to clear all logged diagnostic codes and then verify that the repair eliminates the fault.</p> <p>Result: The diagnostic code is still present with the replacement ECM.</p> <p>Contact the DSN.</p>

CAT C3.4B Engine Parts
Contact phone: 269 673 1638
Email: EngineParts@HeavyEquipmentRestorationParts.com
Alternate email: engineparts2@gmail.com
Website: www.CATC34B.com
Related website: www.HeavyEquipmentRestorationParts.com
www.FPTIndustrialEngineParts.com



Previous Screen



Troubleshooting

C3.4B Engines

Media Number -UENR061.1-10

Publication Date -01/02/2015

i06229778

Injector Solenoid - Test

SMCS - 1290-038-JV

This procedure covers the following codes:

Table 1

Diagnostic Trouble Codes for the Circuit for the Injector Solenoids		
J1939 Code	Description	Notes
651-5	Engine Injector Cylinder #01 : Current Below Normal	These diagnostic codes are designed to indicate an open circuit (low current) in either the solenoid or the wiring for the electronic unit injector in the applicable cylinder. The Electronic Control Module (ECM) detects the following conditions: A low current condition (open circuit) for the applicable cylinder for at least three attempts to actuate the solenoid. The ECM will log the diagnostic code. The engine will have low power and/or rough running. An open circuit will prevent the operation of the electronic unit injector.
652-5	Engine Injector Cylinder #02 : Current Below Normal	
653-5	Engine Injector Cylinder #03 : Current Below Normal	
654-5	Engine Injector Cylinder #04 : Current Below Normal	
651-6	Engine Injector Cylinder #01 : Current Above Normal	These diagnostic codes are designed to indicate a short circuit (high current) in either the solenoid or the wiring for the electronic unit injector in the applicable cylinder. The ECM detects the following conditions: A high current condition (short circuit) for the applicable cylinder
652-6	Engine Injector Cylinder #02 : Current Above Normal	

653-6	Engine Injector Cylinder #03 : Current Above Normal	for at least five attempts to actuate the solenoid.
654-6	Engine Injector Cylinder #04 : Current Above Normal	The ECM will log the diagnostic code. The engine will have low power and/or rough running. A short circuit will prevent the operation of the electronic unit injector.
2797-6	Engine Injector Group 1 : Current Above Normal	The ECM detects the following conditions: A short circuit condition in the driver for injector 1 and injector 4. The fault is present for at least five attempts to actuate the driver. The ECM will log the diagnostic code. The engine will have low power and/or rough running. The engine may shut down. A short circuit will prevent the operation of the two electronic unit injectors.
2797-7	Engine Injector Group 1 : Not Responding Properly	The ECM is unable to actuate any of the injectors. The engine will be derated. The engine will shut down or the engine will be unable to start.
2798-6	Engine Injector Group 2 : Current Above Normal	The ECM detects the following conditions: A short circuit condition in the driver for injector 2 and injector 3. The fault is present for at least five attempts to actuate the driver. The ECM will log the diagnostic code. The engine will have low power and/or rough running. The engine may shut down. A short circuit will prevent the operation of the two electronic unit injectors.

An electrical fault can prevent the electronic unit injector from operating. An open circuit or a short circuit in the ECM that is unique to one electronic unit injector will prevent that electronic unit injector from operating. An open circuit or a short circuit in common wiring within the ECM can prevent the two electronic unit injectors that share that common wiring from operating. Injector 1 and injector 4 share common wiring within the ECM. Injector 2 and injector 3 share common wiring within the ECM.

Perform this procedure under conditions that are identical to the conditions that exist when the fault occurs. Typically, faults with the injector solenoid occur when the engine is warmed up and/or when the engine is under vibration (heavy loads).

These engines have Electronic Unit Injectors (EUI). The ECM sends a pulse to each injector solenoid. The pulse is sent at the correct time and at the correct duration for a given engine load and speed. The solenoid is mounted on top of the fuel injector body.

If an open circuit is detected in the solenoid circuit, a diagnostic code is generated. The ECM continues to try to fire the injector. If a short circuit is detected, a diagnostic code is generated. The ECM will periodically try to fire the injector. If the short circuit remains, this sequence of events will be repeated until the fault is corrected.

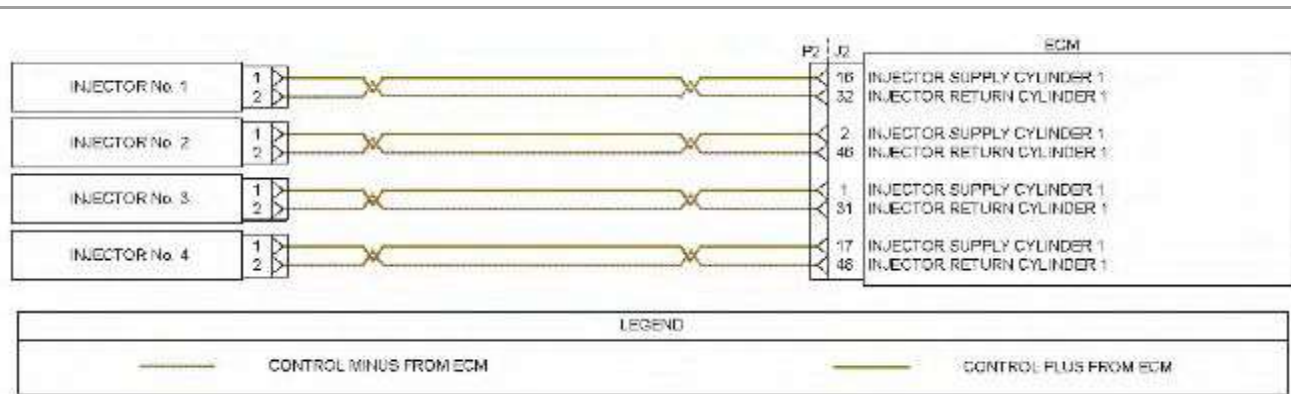

Illustration 1

g03616577

Schematic of the circuit for the injector solenoids

Not all connectors are shown. Refer to the electrical schematic for the engine.

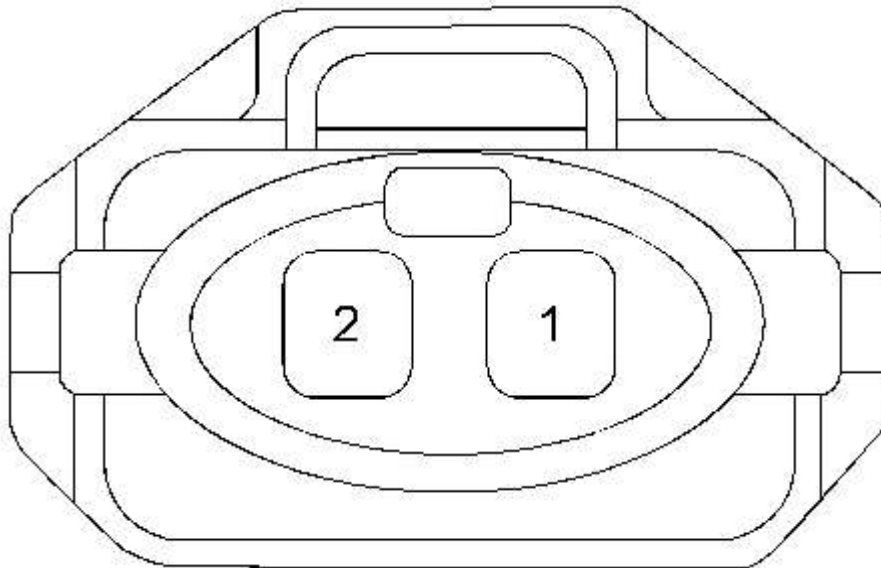

Illustration 2

g02373637

Typical example of the harness connector for the fuel injectors

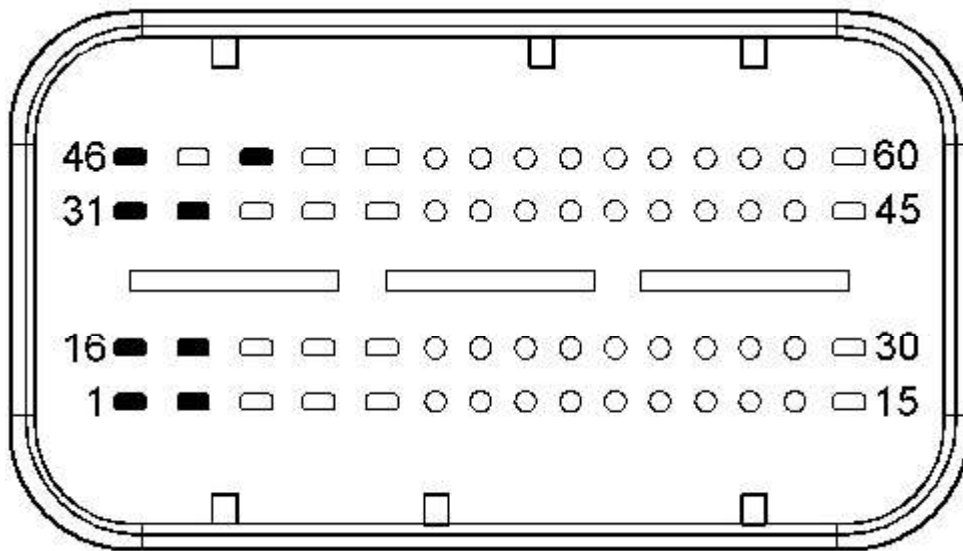

Illustration 3

g02373216

- (1) Cylinder 3 injector supply
- (2) Cylinder 2 injector supply
- (16) Cylinder 1 injector supply
- (17) Cylinder 4 injector supply
- (31) Cylinder 3 injector return
- (32) Cylinder 1 injector return
- (46) Cylinder 2 injector return
- (48) Cylinder 4 injector return



WARNING

Electrical Shock Hazard. The electronic unit injectors use DC voltage. The ECM sends this voltage to the electronic unit injectors. Do not come in contact with the harness connector for the electronic unit injectors while the engine is operating. Failure to follow this instruction could result in personal injury or death.

Table 2

Troubleshooting Test Steps	Values	Results
<p>1. Inspect Electrical Connectors and Wiring</p> <p>A. Turn the keyswitch to the OFF position. A strong electrical shock hazard is present</p>	<p>Damaged wire or connector</p>	<p>Result: A damaged wire or damaged connector was found. A fuse is blown.</p> <p>Repair: Repair the damaged wire or the damaged connector. Replace any blown</p>

<p>if the keyswitch is not turned OFF.</p> <p>B. Thoroughly inspect the connectors at the injectors. Refer to Troubleshooting, "Electrical Connectors - Inspect" for details.</p> <p>C. Inspect the terminals on the P1/J1 ECM connector and all other connectors associated with the injector solenoid circuits.</p> <p>D. Perform a 30 N (6.7 lb) pull test on each of the wires in the ECM connector that are associated with injector solenoids.</p> <p>E. Check the harness and wiring for abrasion and for pinch points from the injectors to the ECM.</p>		<p>fuses</p> <p>Use the electronic service tool to clear all logged diagnostic codes. Verify that the repair eliminates the fault.</p> <p>Result: All connectors, pins, and sockets are correctly connected and/or inserted and the harness is free of corrosion, of abrasion or of pinch points.</p> <p>Proceed to Test Step 2.</p>
<p>2. Check for Active Diagnostic Codes</p> <p>A. Connect the electronic service tool to the diagnostic connector.</p> <p>B. Start the engine.</p> <p>C. Allow the engine to warm up to the normal operating temperature.</p> <p>D. Stop the engine.</p> <p>E. Turn the keyswitch to the ON position. Note: Wait at least 30 seconds for activation of the diagnostic codes.</p> <p>F. Use the electronic service tool in order to verify if any of the diagnostic codes that are listed in Table 1 are active or recently logged.</p>	<p>Diagnostic codes</p>	<p>Result: An -5 diagnostic code is active or recently logged.</p> <p>Note the cylinders that the codes are applicable to. Proceed to Test Step 3.</p> <p>Result: An -6 diagnostic code is active or recently logged.</p> <p>Note the cylinders that the codes are applicable to. Proceed to Test Step 5.</p> <p>Result: A 2797-7 diagnostic code is active.</p> <p>Proceed to Test Step 7.</p>
<p>3. Create a Short at the Injector Connector</p> <p>A. Turn the keyswitch to the OFF position. A strong electrical shock hazard is present</p>	<p>Diagnostic codes</p>	<p>Result: A -6 diagnostic code was active with the jumper installed.</p> <p>Repair: Thoroughly inspect the electrical connector on the suspect injector and the</p>

<p>if the keyswitch is not turned OFF.</p> <p>B. Disconnect the connector from the suspect injector.</p> <p>C. Fabricate a jumper wire 100 mm (4 inch) long.</p> <p>D. Install the jumper wire between terminal 1 and terminal 2 on the harness connector for the suspect injector.</p> <p>E. Start the engine. Wait at least 30 seconds for activation of the diagnostic codes.</p> <p>F. Use the electronic service tool to check for active diagnostic codes.</p> <p>G. Turn the keyswitch to the OFF position.</p> <p>H. Remove the jumper wire.</p>		<p>harness connector for the suspect injector. Ensure that the connectors are free from corrosion. Reconnect the connector for the suspect injector.</p> <p>Start the engine.</p> <p>If the fault is still present, replace the faulty injector. Refer to Disassembly and Assembly, "Electronic Unit Injector - Remove" and Disassembly and Assembly, "Electronic Unit Injector - Install".</p> <p>Use the electronic service tool to clear all logged diagnostic codes and verify that the repair eliminates the fault.</p> <p>Result: A -5 diagnostic code is still present with the jumper installed.</p> <p>Proceed to Test Step 4.</p>
<p>4. Create a Short at the ECM Connector</p> <p>A. Turn the keyswitch to the OFF position. A strong electrical shock hazard is present if the keyswitch is not turned OFF.</p> <p>B. Disconnect the P2 connector.</p> <p>C. Fabricate a jumper wire 100 mm (4 inch) long.</p> <p>D. Install the jumper wire between the supply and return pins for the suspect cylinder on the J2 connector. Refer to Illustration 3 for the correct terminals.</p> <p>E. Turn the keyswitch to the ON position. Wait at least 30 seconds for activation of the diagnostic codes.</p> <p>Note: Diagnostic codes for all of the engine sensors will be active with the P2 connector disconnected. Ignore all other codes and only look for codes relating to the suspect injector.</p>	<p>Diagnostic codes</p>	<p>Result: A -6 diagnostic code is active with the jumper installed.</p> <p>The fault is in the wiring for the suspect injector.</p> <p>Repair: Check all wiring between the suspect injector and the ECM. Refer to the Electrical Schematic for the engine. Replace the faulty wiring.</p> <p>Use the electronic service tool to clear all logged diagnostic codes and verify that the repair eliminates the fault.</p> <p>Result: A -5 diagnostic code is still active with the jumper installed.</p> <p>Proceed to Test Step 7.</p>

<p>F. Use the electronic service tool to check for active diagnostic codes.</p> <p>G. Turn the keyswitch to the OFF position.</p> <p>H. Remove the jumper wire.</p>		
<p>5. Create an Open Circuit at the Injector Connector or Connectors</p> <p>A. Turn the keyswitch to the OFF position. A strong electrical shock hazard is present if the keyswitch is not turned OFF.</p> <p>B. Disconnect the connector for any suspect injectors.</p> <p>C. Turn the keyswitch to the ON position. Wait at least 30 seconds for activation of the diagnostic codes.</p> <p>D. Use the electronic service tool to check for active diagnostic codes.</p> <p>E. Turn the keyswitch to the OFF position.</p>	<p>Diagnostic codes</p>	<p>Result: A -5 diagnostic code is active with the injectors disconnected.</p> <p>Repair: Thoroughly inspect the electrical connectors on the suspect injectors and the harness connector for the suspect injectors. Ensure that the connectors are free from corrosion. Reconnect the connector for the injectors.</p> <p>Start the engine.</p> <p>If the fault is still present, replace the faulty injectors. Refer to Disassembly and Assembly, "Electronic Unit Injector - Remove" and Disassembly and Assembly, "Electronic Unit Injector - Install".</p> <p>Use the electronic service tool to clear all logged diagnostic codes and verify that the repair eliminates the fault.</p> <p>Result: A -6 diagnostic code is still active with the injectors disconnected.</p> <p>Proceed to Test Step 6.</p>
<p>6. Create an Open Circuit at the ECM Connector</p> <p>A. Turn the keyswitch to the OFF position. A strong electrical shock hazard is present if the keyswitch is not turned OFF.</p> <p>B. Disconnect connector P2 from the ECM.</p> <p>C. Thoroughly inspect the P2 connector. Refer to Troubleshooting, "Electrical Connectors - Inspect".</p> <p>D. Turn the keyswitch to the ON position.</p>	<p>Diagnostic Codes</p>	<p>Result: A -5 diagnostic code is active with the P2 connector disconnected.</p> <p>The fault is in the wiring for the suspect injector.</p> <p>Repair: Check all wiring between the suspect injector and the ECM. Refer to the Electrical Schematic for the engine. Replace the faulty wiring.</p> <p>Use the electronic service tool to clear all logged diagnostic codes and verify that the repair eliminates the fault.</p> <p>Result: A -6 diagnostic code is still active</p>

<p>Wait for at least 30 seconds for activation of the diagnostic codes.</p> <p>Note: Diagnostic codes for all of the engine sensors will be active with the P2 connector disconnected. Ignore all other diagnostic codes and only look for codes relating to the suspect injectors.</p> <p>E. Use the electronic service tool to check for active diagnostic codes.</p> <p>F. Turn the keyswitch to the OFF position.</p>		<p>with the P2 connector disconnected.</p> <p>Proceed to Test Step 7.</p>
<p>7. Check if a Replacement ECM Eliminates the Fault</p> <p>A. Contact the Dealer Solution Network (DSN).</p> <p>B. If the DSN recommends the use of a replacement ECM, install a replacement ECM. Refer to Troubleshooting, "ECM - Replace".</p> <p>C. Use the electronic service tool to recheck the system for active diagnostic codes.</p>	<p>Diagnostic codes</p>	<p>Result: There are no active diagnostic codes with the replacement ECM.</p> <p>Repair: Reconnect the suspect ECM. If the fault returns with the suspect ECM, replace the ECM.</p> <p>Use the electronic service tool in order to clear all logged diagnostic codes and then verify that the repair eliminates the fault.</p> <p>Result: The diagnostic code is still present with the replacement ECM.</p> <p>Contact the DSN.</p>

CAT C3.4B Engine Parts
Contact phone: 269 673 1638
Email: EngineParts@HeavyEquipmentRestorationParts.com
Alternate email: engineparts2@gmail.com
Website: www.CATC34B.com
Related website: www.HeavyEquipmentRestorationParts.com

www.FPTIndustrialEngineParts.com



Previous Screen



Troubleshooting
C3.4B Engines

Media Number -UENR0611-10

Publication Date -01/02/2015

i06225853

Inlet Air Is Restricted

SMCS - 1087-035

The Electronic Control Module (ECM) detects a fault with the air flow through the air filter. If the air flow has been restricted, the ECM will generate one of the following codes:

Table 1

Code for Inlet Air Restriction		
J1939 Code	Description	Information
107-15	Engine Air Filter 1 Differential Pressure : High - least severe (1)	The Electronic Control Module (ECM) detects the following conditions: The air filter restriction switch indicates that the air filter is blocked. The engine has been operating for at least 60 seconds. The engine speed is at least 1800 rpm. If equipped, the warning lamp will flash
107-16	Engine Air Filter 1 Differential Pressure: High - moderate severity (2)	The ECM detects that a 107-15 diagnostic code has been active for at least 30 minutes. If equipped, the warning lamp will flash. The engine will be derated.

Complete the procedure in the order in which the steps are listed.

Table 2

Troubleshooting Test Steps	Values	Results
1. Check the Air Filter Element	Plugged Air	Result: The air filter is clogged.

<p>A. Check the air intake system for plugged air filters or for damaged air filters. If the engine is equipped with an air intake precleaner, verify the proper operation of the air intake precleaner.</p>	<p>Filter</p>	<p>Repair: Clean or replace the air filter. Verify that the problem is resolved.</p> <p>Result: The air filter is not clogged.</p> <p>Proceed to Test Step 2.</p>
<p>2. Check the Air Inlet Piping</p> <p>A. Check the air inlet piping for damage or restrictions.</p>	<p>Damaged Air Inlet Piping</p>	<p>Result: The air inlet piping is damaged or has restrictions.</p> <p>Repair: Repair the piping or replace the piping. Verify that the problem is resolved.</p> <p>Result: The air inlet piping does not have damage or restrictions.</p> <p>Proceed to Test Step 3.</p>
<p>3. Check the Enclosure Ventilation</p> <p>A. Check that the engine has been installed in an enclosure that is sufficiently ventilated.</p>	<p>Enclosure Ventilation</p>	<p>Result: The engine does not have sufficient ventilation.</p> <p>Repair: Repair the ventilation for the enclosure. Verify that the problem is resolved.</p>

CAT C3.4B Engine Parts
 Contact phone: 269 673 1638
 Email: EngineParts@HeavyEquipmentRestorationParts.com
 Alternate email: engineparts2@gmail.com
 Website: www.CATC34B.com
 Related website: www.HeavyEquipmentRestorationParts.com

www.FPTIndustrialEngineParts.com



Previous Screen



Troubleshooting
C3.4B Engines

Media Number -UENR0611-10

Publication Date -01/02/2015

i06225877

Intake Manifold Air Pressure Is High

SMCS - 1058-035-PX

This procedure covers the following diagnostic code:

Table 1

Diagnostic Trouble Codes for High Intake Manifold Air Pressure		
J1939 Code	Description	Notes
1127-16	Engine Turbocharger 1 Boost Pressure : High - moderate severity (2)	<p>The Electronic Control Module (ECM) detects that the actual intake manifold air pressure is greater than the desired intake manifold air pressure by 50 kPa (7.25 psi) for at least 10 seconds.</p> <p>If equipped, the warning lamp will flash. The engine will be derated.</p> <p>If the actual intake manifold pressure is within 25 kPa (3.6 psi) of the desired intake manifold air pressure for at least 11 minutes, the code will reset.</p>

Probable Causes

- Air inlet and exhaust restrictions
- Turbocharger wastegate
- Wastegate regulator

Recommended Actions

Note: The procedures have been listed in order of probability. Complete the procedures in order.

Table 2

Troubleshooting Test Steps	Values	Results
<p>1. Air Inlet and Exhaust Restrictions</p> <p>A. Check the air filter for damage.</p> <p>B. Check the air inlet and exhaust system for restrictions and/or leaks. Refer to Systems Operation, Testing, and Adjusting, "Air Inlet and Exhaust System - Inspect".</p>	Air inlet and exhaust system	<p>Result: Defects found in the air inlet or exhaust systems.</p> <p>Repair: Repair any defects. Replace damaged components.</p> <p>Result: The air inlet and exhaust systems are OK.</p> <p>Proceed to Test Step 2.</p>
<p>2. Turbocharger Wastegate</p> <p>A. Check the operation of the turbocharger wastegate.</p> <p>B. Check the operation of the wastegate actuator. Refer to Systems Operation, Testing, and Adjusting, "Turbocharger - Inspect".</p>	Turbocharger wastegate	<p>Result: There is a suspected fault in the wastegate or the wastegate actuator.</p> <p>Repair: Replace the turbocharger. Refer to Disassembly and Assembly, "Turbocharger - Remove" and Disassembly and Assembly, "Turbocharger - Install".</p> <p>Result: The wastegate and the wastegate actuator operate correctly.</p> <p>Proceed to Test Step 3.</p>
<p>3. Wastegate Regulator</p> <p>A. Use the electronic service tool to check for diagnostic trouble codes that relate to the wastegate regulator.</p>	Wastegate regulator	<p>Result: Diagnostic codes are present that relate to the wastegate regulator.</p> <p>Repair: Rectify the cause of any related codes. Refer to Troubleshooting, "Diagnostic Trouble Codes".</p> <p>Result: There are no diagnostic codes that relate to the wastegate regulator.</p> <p>Contact the Dealer Solution Network (DSN).</p>



Previous Screen



Troubleshooting
C3.4B Engines

Media Number -UENR0611-10

Publication Date -01/02/2015

i06225887

Intake Manifold Air Pressure Is Low

SMCS - 1058-035-PX

This procedure covers the following diagnostic code:

Table 1

Diagnostic Trouble Codes for Low Intake Manifold Air Pressure		
J1939 Code	Description	Notes
1127-18	Engine Turbocharger 1 Boost Pressure : Low - moderate severity (2)	<p>The Electronic Control Module (ECM) detects the following conditions:</p> <p>The actual intake manifold air pressure is less than the desired intake manifold air pressure for at least 10 seconds. The difference between the two values is dependent on engine operating conditions.</p> <p>The engine speed is between 1000 rpm and 4000 rpm.</p> <p>The engine coolant temperature is greater than 45° C (113° F).</p> <p>There are no active 102 diagnostic codes for the intake manifold air pressure sensor.</p> <p>An active regeneration is not in progress.</p> <p>There are no other active engine derates.</p> <p>If equipped, the warning lamp will flash. The engine will be derated.</p> <p>The fault will be cleared when the intake manifold air pressure is within the acceptable range for at least 11 minutes.</p>

Probable Causes

- Intake air filter

- Air intake system
- Wastegate regulator
- Turbocharger

Recommended Actions

Note: The procedures have been listed in order of probability. Complete the procedures in order.

Table 2

Troubleshooting Test Steps	Values	Results
<p>1. Intake Air Filter</p> <p>A. Check the air filter restriction indicator, if equipped.</p> <p>B. Ensure that the air filter is clean and serviceable.</p>	Air filter	<p>Result: The air filter is blocked.</p> <p>Repair: Replace the air filter element. Refer to the Operation and Maintenance Manual, "Engine Air Cleaner Element - Replace".</p> <p>Result: The air filter is OK.</p> <p>Proceed to Test Step 2.</p>
<p>2. Air Intake System</p> <p>A. Check the air intake system for the following defects:</p> <ul style="list-style-type: none"> · Blockages · Restrictions · Damage to the air intake ducts and hoses · Loose connections and air leaks 	Air intake	<p>Result: The air intake system is blocked, restricted, damaged, or loose.</p> <p>Repair: Make all necessary repairs to the air intake system.</p> <p>Result: The air intake system is OK.</p> <p>Proceed to Test Step 3.</p>
<p>3. Wastegate Regulator</p> <p>A. Use the electronic service tool to check for diagnostic trouble codes that relate to the wastegate regulator.</p>	Wastegate regulator	<p>Result: Diagnostic codes are present that relate to the wastegate regulator.</p> <p>Repair: Rectify the cause of any related codes. Refer to Troubleshooting, "Diagnostic Trouble Codes".</p> <p>Result: There are no diagnostic codes that relate to the wastegate regulator.</p> <p>Proceed to Test Step 4.</p>

<p>4. Turbocharger</p> <p>Note: The turbocharger that is installed on the engine is a nonserviceable item. If any mechanical fault exists, then the turbocharger must be replaced.</p> <p>A. Check that the compressor housings for the turbochargers are free of dirt and debris.</p> <p>B. Check that the turbine housings for the turbochargers are free of dirt and debris.</p> <p>C. Check that the turbine blades rotate freely in the turbochargers.</p>	<p>Turbocharger</p>	<p>Result: There is a fault with the turbocharger.</p> <p>Repair: Replace the turbocharger. Refer to Disassembly and Assembly, "Turbocharger - Remove" and Disassembly and Assembly, "Turbocharger - Install".</p> <p>Result: The turbocharger is OK.</p> <p>Contact the Dealer Solution Network (DSN).</p>
--	---------------------	--

CAT C3.4B Engine Parts
 Contact phone: 269 673 1638
 Email: EngineParts@HeavyEquipmentRestorationParts.com
 Alternate email: engineparts2@gmail.com
 Website: www.CATC34B.com
 Related website: www.HeavyEquipmentRestorationParts.com
www.FPTIndustrialEngineParts.com



Previous Screen



Troubleshooting
C3.4B Engines

Media Number -UENR0611-10

Publication Date -01/02/2015

i06225888

Intake Manifold Air Temperature Is High

SMCS - 1058-035-TA

The Electronic Control Module (ECM) monitors the intake manifold air for excessive temperature.

Use this procedure to determine the cause of high intake manifold air temperature.

Probable Causes

- Coolant level
- Air-to-air aftercooler (ATAAC)
- Cooling fan
- Air inlet and exhaust system
- Ambient temperature
- Altitude
- Running condition

Recommended Actions

Note: The procedures have been listed in order of probability. Complete the procedures in order.

Table 1

Troubleshooting Test Steps	Values	Results
<p>1. Coolant Level</p> <p>A. Check that the coolant is filled to the correct</p>	Coolant	Result: The coolant level is low.

<p>level.</p> <p>Note: If the coolant level is too low, air will get into the cooling system. Air in the cooling system will cause a reduction in coolant flow.</p>		<p>Repair: Fill the coolant system to the correct level. Refer to the Operation and Maintenance Manual, "Coolant Level - Check".</p> <p>Result: The coolant level is OK.</p> <p>Proceed to Test Step 2.</p>
<p>2. Air-to-Air Aftercooler (ATAAC)</p> <p>A. Check the ATAAC for debris or damage.</p> <p>Note: Debris between the fins of the ATAAC core restricts air flow through the core.</p>	ATAAC	<p>Result: The ATAAC has excessive debris or is damaged.</p> <p>Repair: Clear the debris from the ATAAC or replace the ATAAC.</p> <p>Result: The ATAAC is OK.</p> <p>Proceed to Test Step 3.</p>
<p>3. Cooling Fan</p> <p>A. Check the operation of the cooling fan.</p> <p>Note: A fan that is not turning at the correct speed can result in insufficient airflow through the aftercooler core.</p>	Cooling fan	<p>Result: The cooling fan is not operating correctly.</p> <p>Repair: Investigate the cause of the incorrect fan operation</p> <p>Result: The cooling fan is operating correctly.</p> <p>Proceed to Test Step 4.</p>
<p>4. Air Intake and Exhaust System</p> <p>A. Check the air intake and exhaust system for the following defects:</p> <ul style="list-style-type: none"> · Blockages · Restrictions · Damage to the air intake ducts and hoses · Loose connections and air leaks 	Air intake and exhaust	<p>Result: The air intake or exhaust system is blocked, restricted, damaged, or loose.</p> <p>Repair: Make all necessary repairs to the air intake system.</p> <p>Result: The air intake and exhaust system is OK.</p>

		Proceed to Test Step 5.
<p>5. Ambient Temperature</p> <p>A. Check for a high ambient temperature.</p> <p>Note: When outside temperatures are too high, there is insufficient temperature difference between the outside air and the intake air.</p>	Ambient Temperature	<p>Result: The ambient air temperature is high.</p> <p>Repair: Operate the engine at reduced speed or reduced power.</p> <p>Result: The ambient air temperature is OK.</p> <p>Proceed to Test Step 6.</p>
<p>6. Altitude</p> <p>A. Check for operation at high altitude.</p> <p>Note: The cooling capacity of the ATAAC is reduced as the engine is operated at higher altitudes.</p>	Altitude	<p>Result: The engine is being operated at high altitude.</p> <p>Repair: Operate the engine at reduced speed or reduced power.</p> <p>Result: The engine is not being operated at high altitude.</p> <p>Proceed to Test Step 7.</p>
<p>7. Running Condition</p> <p>A. Check that the engine is not operating in the lug condition.</p> <p>Note: When the load that is applied to the engine is too large, the engine will run in the lug condition. When the engine is running in the lug condition, engine rpm does not increase with an increase of fuel. This lower engine rpm causes a reduction in coolant flow through the system.</p>	Running condition	<p>Result: The engine is operating in the lug condition.</p> <p>Repair: Reduce the load on the engine or, if possible, increase the power rating of the engine.</p> <p>Result: The engine is not operating in the lug condition.</p> <p>Contact the Dealer Solution Network (DSN).</p>



Previous Screen



Troubleshooting

C3.4B Engines

Media Number -UENR061.1-10

Publication Date -01/02/2015

i06229833

Mode Selection - Test

SMCS - 7332-038

Table 1

Diagnostic Trouble Codes for the Mode Selection Circuit		
J1939 Code	Description	Notes
2880-2	Engine Operator Primary Intermediate Speed Select : Erratic, Intermittent, or Incorrect	<p>The Electronic Control Module (ECM) detects the following conditions:</p> <p>The signal voltage from the mode selection switch is between 0.35 V and 4.8 V.</p> <p>The signal voltage from the mode selection switch is not valid for any of the available modes for at least 0.5 seconds.</p> <p>The battery voltage is at least 10 V.</p> <p>The warning lamp will come on.</p>
2880-3	Engine Operator Primary Intermediate Speed Select : Voltage Above Normal	<p>The ECM detects the following conditions:</p> <p>The signal voltage from the mode selection switch is above 4.8 VDC for at least 0.5 seconds.</p> <p>The battery voltage is at least 10 VDC.</p> <p>The warning lamp will come on.</p>
2880-4	Engine Operator Primary Intermediate Speed Select : Voltage Below Normal	<p>The ECM detects the following conditions:</p> <p>The signal voltage from the mode selection switch is less than 0.35 VDC for at least 0.5 seconds.</p>

The battery voltage is at least 10 VDC.

The warning lamp will come on.

The mode selection switch uses resistors to modify the voltage signal from the ECM. The resistance of the switch changes dependent on which position the switch is in. The ECM uses the signal voltage to determine which mode has been selected.

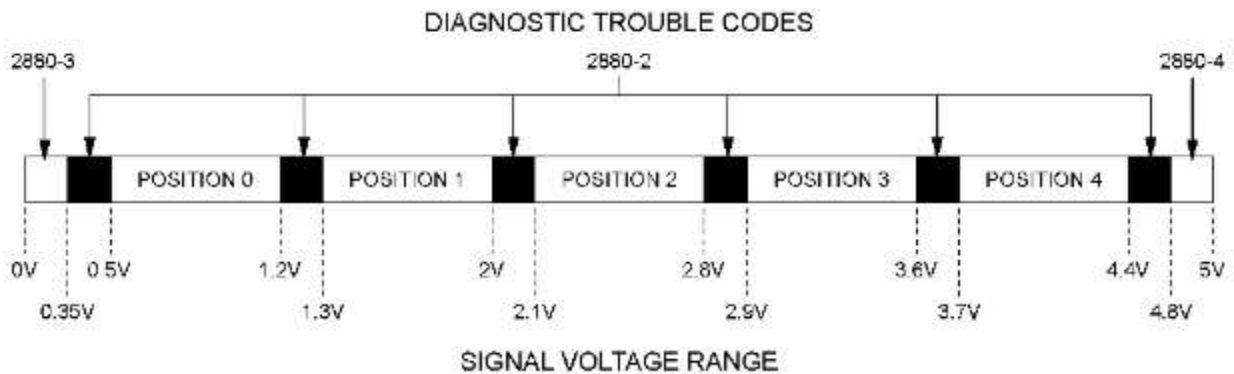

Illustration 1

g03117957

View of the signal voltage range for the mode selection switch

Note: Position (4) is not available on the mode selection switch. If the signal voltage range is between 3.7 and 4.4 VDC, the mode that is selected will be the same as position (3).

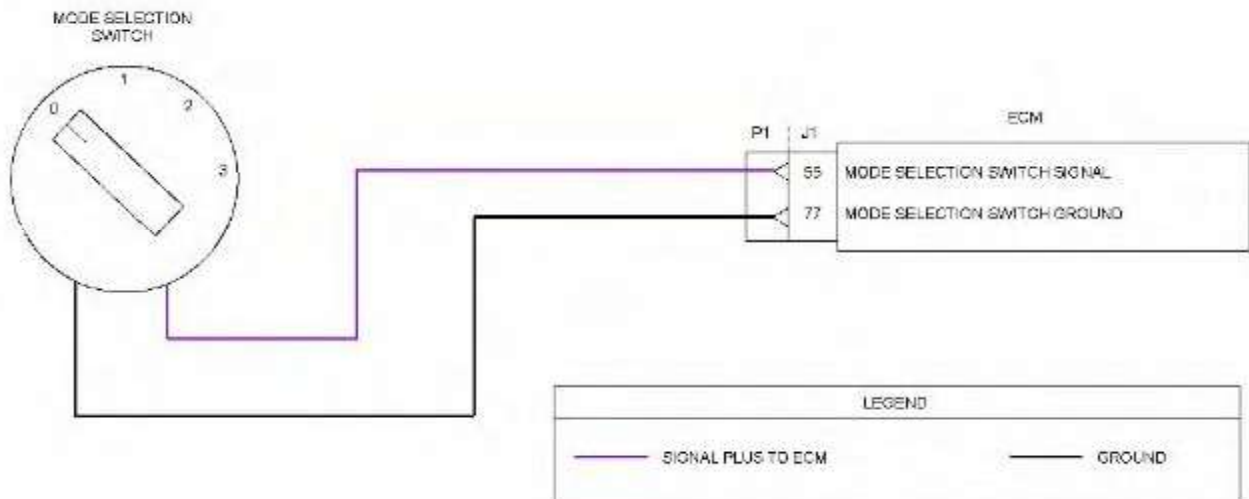

Illustration 2

g03728025

Typical example of the schematic for the mode selection switch

Not all connectors are shown. Refer to the Electrical Schematic for the application.

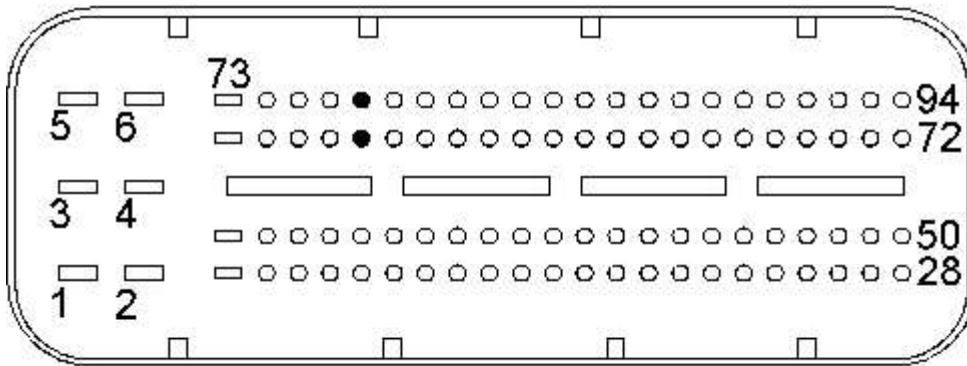

Illustration 3

g02723018

Typical view of the pin locations on the P1 connector for the mode selection switch

(55) Mode selection switch signal

(77) Mode selection switch ground

Table 2

Troubleshooting Test Steps	Values	Results
<p>1. Inspect Electrical Connectors and Wiring</p> <p>A. Thoroughly inspect the terminal connections on the P1/J1 connector.</p> <p>B. Thoroughly inspect the connector for the mode selection switch.</p> <p>C. Refer to Troubleshooting, "Electrical Connectors - Inspect".</p> <p>D. Perform a 30 N (6.7 lb) pull test on each of the wires in the connectors that are associated with the mode selection switch.</p> <p>E. Check the harness for abrasions and for pinch points from the switch back to the ECM.</p>	<p>Damaged wire or connector</p>	<p>Result: A damaged wire or damaged connector was not found.</p> <p>Proceed to Test Step 2.</p> <p>Result: A damaged wire or damaged connector was found.</p> <p>Repair: Repair the damaged wire or the damaged connector. Use the electronic service tool to clear all logged diagnostic codes. Verify that the repair eliminates the fault.</p>
<p>2. Check for Active or Recently Logged Diagnostic Codes</p>	<p>Diagnostic</p>	<p>Result: A 2880-4 diagnostic code is active.</p>

<p>A. Turn the keyswitch to the OFF position.</p> <p>B. Connect the electronic service tool to the diagnostic connector.</p> <p>C. Turn the keyswitch to the ON position. Do not start the engine.</p> <p>D. Check for active diagnostic codes with the mode selection switch in each position. Wait at least 10 seconds with the switch in each position for activation of the diagnostic codes.</p>	<p>Trouble Codes</p>	<p>Proceed to Test Step 3.</p> <p>Result: A 2880-3 diagnostic code is active.</p> <p>Proceed to Test Step 4.</p> <p>Result: A 2880-2 diagnostic code is active.</p> <p>Proceed to Test Step 5.</p>
<p>3. Create an Open Circuit at the Switch</p> <p>A. Turn the keyswitch to the OFF position.</p> <p>B. Disconnect the mode selection switch.</p> <p>C. Turn the keyswitch to the ON position.</p> <p>D. Use the electronic service tool to check for an active 2880 diagnostic code. Wait at least 10 seconds for activation of the diagnostic codes.</p> <p>E. Turn the keyswitch to the OFF position.</p>	<p>Diagnostic codes</p>	<p>Result: A 2880-3 diagnostic code is active with the switch disconnected.</p> <p>Repair: Replace the mode selection switch. Use the electronic service tool to clear all logged diagnostic codes and verify that the repair eliminates the fault.</p> <p>Result: A 2880-4 diagnostic code is still active with the switch disconnected.</p> <p>Reconnect the switch and proceed to Test Step 7.</p>
<p>4. Create a Short at the Switch Connector</p> <p>A. Turn the keyswitch to the OFF position.</p> <p>B. Disconnect the mode selection switch.</p> <p>C. Fabricate a jumper wire and install the jumper wire between the two harness connector terminals for the mode selection switch.</p> <p>D. Turn the keyswitch to the ON position.</p> <p>E. Use the electronic service tool to check for an active 2880 diagnostic code. Wait at least 10</p>	<p>Diagnostic codes</p>	<p>Result: A 2880-4 diagnostic code is active with the jumper installed.</p> <p>Repair: Replace the mode selection switch. Use the electronic service tool to clear all logged diagnostic codes and verify that the repair eliminates the fault.</p> <p>Result: A 2880-3 diagnostic code is still active with the jumper installed.</p>

<p>seconds for activation of the diagnostic codes.</p> <p>F. Turn the keyswitch to the OFF position.</p> <p>G. Remove the jumper wire.</p>		<p>Reconnect the mode selection switch and proceed to Test Step 7.</p>
<p>5. Check the Voltage at the Switch Connector</p> <p>A. Turn the keyswitch to the OFF position.</p> <p>B. Disconnect the mode selection switch.</p> <p>C. Turn the keyswitch to the ON position.</p> <p>D. Use a suitable multimeter to measure the voltage between the signal terminal and the ground terminal at the switch connector.</p> <p>E. Turn the keyswitch to the OFF position.</p>	<p>4.9 V to 5.1 V</p>	<p>Result: The voltage is within the expected range.</p> <p>Repair: Replace the mode selection switch. Use the electronic service tool to clear all logged diagnostic codes and verify that the repair eliminates the fault.</p> <p>Result: The voltage is not within the expected range.</p> <p>Proceed to Test Step 6.</p>
<p>6. Check the Wiring for High Resistance</p> <p>A. Turn the keyswitch to the OFF position.</p> <p>B. Disconnect the mode selection switch. Disconnect the P1 connector.</p> <p>C. Use a suitable multimeter to measure the resistance between the following points:</p> <ul style="list-style-type: none"> · P1:55 to the signal terminal at the switch connector · P1:77 to the ground terminal at the switch connector 	<p>Less than 5 Ohms</p>	<p>Result: At least one of the resistance measurements is greater than 5 Ohms. The fault is in the wiring between the switch connector and the P1 connector.</p> <p>Repair: Replace the faulty wiring. Use the electronic service tool to clear all logged diagnostic codes and verify that the repair eliminates the fault.</p> <p>Result: Both resistance measurements are less than 5 Ohms.</p> <p>Proceed to Test Step 7.</p>
<p>7. Check the Wiring for a Short Circuit</p> <p>A. Turn the keyswitch to the OFF position.</p>	<p>Greater than 1 k Ohm</p>	<p>Result: At least one of the resistance measurements is less than 1 k Ohm. There is a short in the wiring</p>

B. Disconnect the P1 connector from the ECM.

C. Disconnect the mode selection switch.

D. Use a suitable multimeter to measure the resistance between the following points:

- P1:55 and all other terminals on the P1 connector
- P1:77 and all terminals on the P1 connector

between the mode selection switch and the P1 connector.

Repair: Replace the faulty wiring. Use the electronic service tool to clear all logged diagnostic codes and verify that the repair eliminates the fault.

Result: All resistance measurements are greater than 1 k Ohm.

Contact the Dealer Solution Network (DSN).



Previous Screen



Troubleshooting

C3.4B Engines

Media Number -UENR0611-10

Publication Date -01/02/2015

i06015840

Motorized Valve - Test

SMCS - 5479-038; 5927-038-VL

This procedure covers the following codes:

Table 1

Diagnostic Trouble Codes for the Motorized Valves		
J1939 Code	Description	Notes
2791-5	Engine Exhaust Gas Recirculation (EGR) Valve Control : Current Below Normal	<p>The Electronic Control Module (ECM) detects the following conditions:</p> <p>A low current condition in the output for the NOx Reduction System (NRS) valve for at least 0.3 seconds.</p> <p>The battery voltage is at least 10 VDC.</p> <p>The engine will be derated. The ECM will log the diagnostic code.</p>
2791-6	Engine Exhaust Gas Recirculation (EGR) Valve Control : Current Above Normal	<p>The ECM detects the following conditions:</p> <p>A high current condition in the output for the NRS valve for at least 0.3 seconds.</p> <p>The battery voltage is at least 10 VDC.</p> <p>The engine will be derated. The ECM will log the diagnostic code.</p>

2791-7	Engine Exhaust Gas Recirculation (EGR) Valve Control : Not Responding Properly	<p>The ECM detects the following conditions:</p> <p>The signal from the NRS valve position sensor indicates that the valve is not in the desired position.</p> <p>The difference between the desired position and the actual position is greater than 12 percent.</p> <p>This diagnostic code can be caused by a loss of the 5 VDC supply to the NRS valve position sensor.</p> <p>The engine will be derated. The ECM will log the diagnostic code.</p>
5419-5	Engine Throttle Actuator #1 : Current Below Normal	<p>The ECM detects the following conditions:</p> <p>A low current condition in the output for the engine intake throttle valve for at least 0.5 seconds.</p> <p>The ECM will log the diagnostic code.</p>
5419-6	Engine Throttle Actuator #1 : Current Above Normal	<p>The ECM detects the following conditions:</p> <p>A high current condition in the output for the engine intake throttle valve for at least 0.5 seconds.</p> <p>The ECM will log the diagnostic code.</p>
5419-7	Engine Throttle Actuator #1 : Not Responding Properly	<p>The ECM detects the following conditions:</p> <p>The signal from the intake throttle valve position sensor indicates that the valve is not in the desired position for at least 0.05 seconds.</p> <p>The difference between the desired position and the actual position is greater than 12 percent.</p> <p>This diagnostic code can be caused by a loss of the 5 VDC supply to the intake throttle valve position sensor.</p> <p>The engine will be derated. The ECM will log the diagnostic code.</p>

The following background information is related to this procedure:

NRS Valve

The NRS valve is used to control the amount of exhaust gas which is recirculated into the intake manifold.

The amount of exhaust gas that is required is calculated by the software that is contained in the ECM. The NRS valve is controlled by a PWM signal from the ECM.

Intake Throttle Valve

The intake throttle valve is used to increase the exhaust gas temperature to aid the Diesel Particulate Filter (DPF) regeneration process.

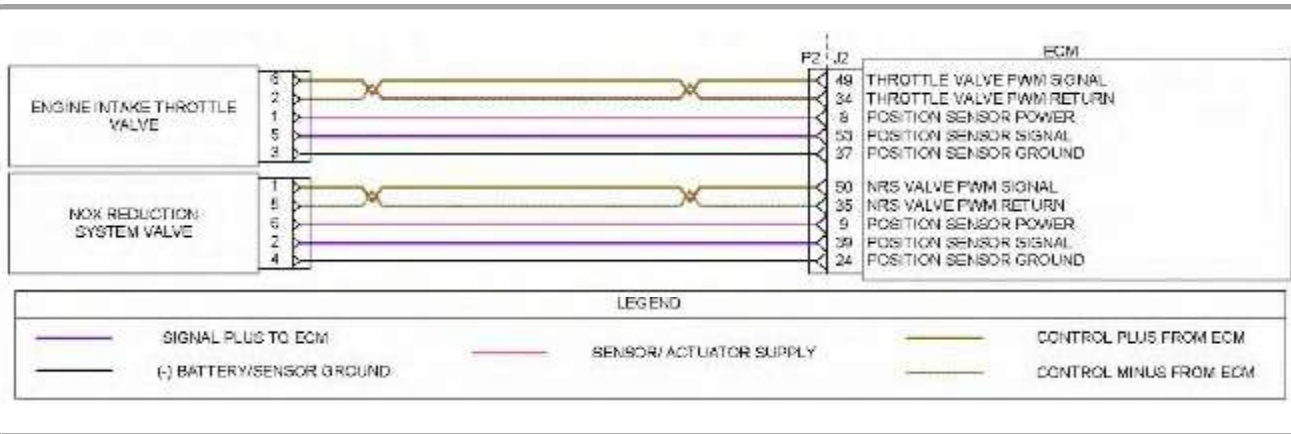

Illustration 1

g03616796

Schematic diagram for the motorized valves

Not all connectors are shown. Refer to the electrical schematic for the machine.

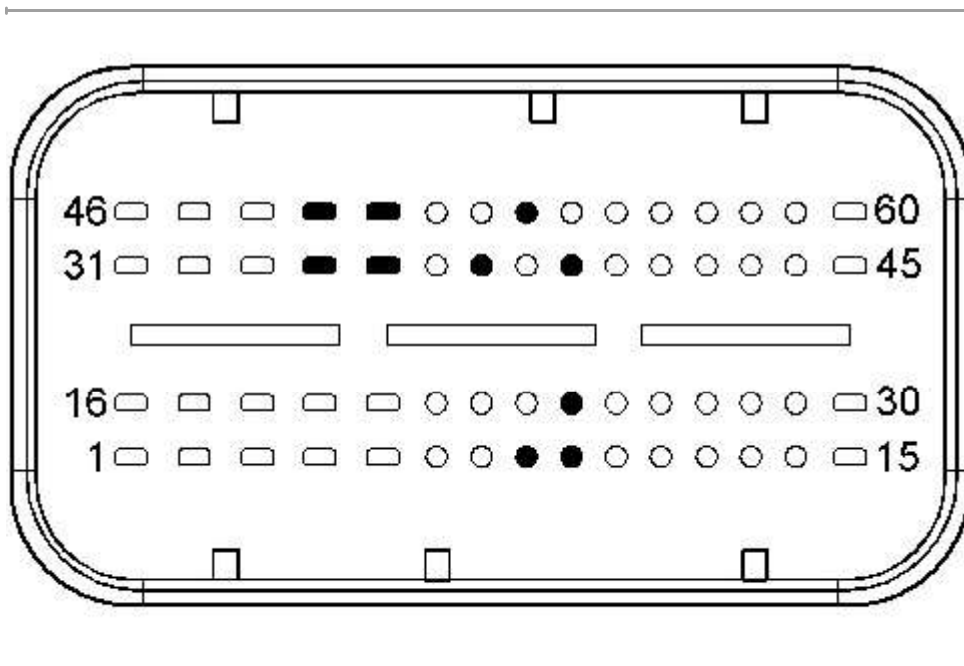

Illustration 2

g03616849

Typical view of the pin locations on the J2 connector for the motorized valves.

- (8) Intake throttle valve position sensor 5 VDC supply
- (9) NRS valve position sensor 5 VDC supply
- (24) NRS valve position sensor ground
- (34) Intake throttle valve return

- (35) NRS valve return
- (37) Intake throttle valve position sensor ground
- (39) NRS valve position sensor signal
- (49) Intake throttle valve PWM signal
- (50) NRS valve PWM signal
- (53) Engine intake throttle valve position sensor signal

Table 2

Troubleshooting Test Steps	Values	Results
<p>1. Inspect Electrical Connectors and Wiring</p> <p>A. Thoroughly inspect connectors for the motorized valves. Refer to Troubleshooting, "Electrical Connectors - Inspect" for details.</p> <p>B. Thoroughly inspect the P2/J2 ECM connector. Refer to Troubleshooting, "Electrical Connectors - Inspect" for details.</p> <p>C. Perform a 30 N (6.7 lb) pull test on each of the wires that are associated with the motorized valves.</p>	<p>Damaged wire or connector</p>	<p>Result: A damaged wire or damaged connector was found.</p> <p>Repair the damaged wire or the damaged connector. Use the electronic service tool to clear all logged diagnostic codes. Verify that the repair eliminates the fault.</p> <p>Result: All connectors, pins, and sockets are correctly connected and/or inserted and the harness is free of corrosion, of abrasion or of pinch points.</p> <p>Proceed to Test Step 2.</p>
<p>2. Check for Diagnostic Codes</p> <p>A. Turn the keyswitch to the OFF position.</p> <p>B. Connect the electronic service tool to the diagnostic connector.</p> <p>C. Turn the keyswitch to the ON position.</p> <p>D. Monitor the electronic service tool for active diagnostic codes and/or logged diagnostic codes.</p>	<p>Diagnostic codes</p>	<p>Result: An XXXX-7 diagnostic code is active or recently logged for one or more of the motorized valves</p> <p>Proceed to Test Step 3.</p> <p>Result: An XXXX-5 diagnostic code is active or recently logged for one or more of the motorized valves.</p> <p>Proceed to Test Step 4.</p> <p>Result: An XXXX-6 diagnostic code is active or recently logged for one or more of the motorized valves.</p> <p>Proceed to Test Step 6.</p>

<p>3. Measure the Sensor Supply Voltage at the Valve Connector</p> <p>A. Turn the keyswitch to the OFF position.</p> <p>B. Disconnect the suspect valve from the engine harness.</p> <p>C. Turn the keyswitch to the ON position.</p> <p>D. Measure the voltage at the harness connector for the valve from the 5 VDC supply terminal of the position sensor to the sensor ground terminal.</p>	<p>4.9 v to 5.1 V</p>	<p>Result: The measured voltage is within the expected range.</p> <p>Install a replacement for the suspect valve. Refer to Disassembly and Assembly for more information.</p> <p>Note: If the NRS valve is replaced, use the electronic service tool to perform the "EGR Valve Learn Reset".</p> <p>Use the electronic service tool in order to clear all logged diagnostic codes and then verify that the repair eliminates the fault.</p> <p>Result: The measured voltage is not within the expected range.</p> <p>The fault is in the wiring between the suspect valve and the ECM P2 connector.</p> <p>Check all of the wiring between the suspect valve and the P2 connector. Refer to the Electrical Schematic for the engine.</p> <p>Replace the suspect wiring.</p> <p>Use the electronic service tool to clear all logged diagnostic codes and verify that the repair eliminates the fault.</p>
<p>4. Create a Short Circuit at the Valve Connector</p> <p>A. Turn the keyswitch to the OFF position.</p> <p>B. Disconnect the connector for the suspect valve.</p> <p>C. Fabricate a jumper wire that is 150 mm (6 inch) long.</p> <p>D. Install the jumper between the PWM signal and return pins on the connector for the suspect valve in order to create a short circuit.</p>	<p>Diagnostic codes</p>	<p>Result: An XXXX-6 is active with the jumper installed.</p> <p>Reconnect the valve. Start the engine. Check for active diagnostic codes on the electronic service tool. Wait at least 30 seconds in order for the codes to be displayed.</p> <p>If the XXXX-5 diagnostic code returns, then replace the valve. Refer to Disassembly and Assembly for the correct procedure.</p> <p>Note: If the NRS valve is replaced, use the electronic service tool to</p>

<p>E. Turn the keyswitch to the ON position. Check for active diagnostic codes on the electronic service tool.</p> <p>F. Remove the jumper wire.</p>		<p>perform the "EGR Valve Learn Reset".</p> <p>Use the electronic service tool to clear all logged diagnostic codes and verify that the repair eliminates the fault.</p> <p>Result: An XXXX-5 diagnostic code is still active with the jumper installed.</p> <p>Proceed to Test Step 5.</p>
<p>5. Create a Short Circuit at the ECM Connector</p> <p>A. Turn the keyswitch to the OFF position.</p> <p>B. Disconnect the P2 connector from the ECM.</p> <p>C. Fabricate a jumper wire that is 150 mm (6 inch) long. Install the jumper wire between the PWM supply wire and the return wire for the suspect valve on the J2 connector.</p> <p>D. Turn the keyswitch to the ON position. Wait at least 30 seconds for activation of the diagnostic codes.</p> <p>Note: Diagnostic codes for all of the engine sensors will be active with the P2 connector disconnected. Ignore all other codes and only look for codes that relate to the suspect valve.</p> <p>E. Look for an active XXXX-6 diagnostic code for the suspect valve.</p> <p>F. Turn the keyswitch to the OFF position.</p>	<p>Diagnostic codes</p>	<p>Result: An XXXX-6 diagnostic code was active with the jumper installed.</p> <p>The fault is in the wiring between the suspect valve and the ECM P2 connector.</p> <p>Check all of the wiring between the suspect valve and the P2 connector. Refer to the Electrical Schematic for the engine.</p> <p>Replace the faulty wiring.</p> <p>Use the electronic service tool to clear all logged diagnostic codes and verify that the repair eliminates the fault.</p> <p>Result: An XXXX-5 diagnostic code is still active with the jumper installed.</p> <p>Proceed to Test Step 8.</p>
<p>6. Create an Open Circuit at the Valve Connector</p> <p>A. Turn the keyswitch to the OFF position.</p> <p>B. Disconnect the connector for the suspect valve in order to create an open circuit.</p> <p>C. Turn the keyswitch to the ON position. Check</p>	<p>Diagnostic Codes</p>	<p>Result: An XXXX-5 diagnostic code is active with the valve disconnected.</p> <p>Reconnect the valve. Start the engine. Check for active diagnostic codes on the electronic service tool. Wait at least 30 seconds in order for the codes to be displayed.</p> <p>If the XXXX-5 diagnostic code</p>

<p>for active diagnostic codes on the electronic service tool. Wait at least 30 seconds in order for the codes to be displayed.</p>		<p>returns, then replace the valve. Refer to Disassembly and Assembly for the correct procedure.</p> <p>Note: If the NRS valve is replaced, use the electronic service tool to perform the "EGR Valve Learn Reset".</p> <p>Use the electronic service tool to clear all logged diagnostic codes and verify that the repair eliminates the fault.</p> <p>Result: An XXXX-6 diagnostic code is still active with the valve disconnected.</p> <p>Proceed to Test Step 7.</p>
<p>7. Create an Open Circuit at the ECM Connector</p> <p>A. Turn the keyswitch to the OFF position.</p> <p>B. Disconnect the P2 connector.</p> <p>C. Turn the keyswitch to the ON position. Wait at least 30 seconds for activation of the diagnostic codes.</p> <p>Note: Diagnostic codes for all of the engine sensors will be active with the P2 connector disconnected. Ignore all other diagnostic codes and only look for codes that relate to the suspect valve.</p> <p>D. Check for an active XXXX-5 diagnostic code for the suspect valve.</p>	<p>Diagnostic codes</p>	<p>Result: An XXXX-5 diagnostic code is active with the P2 connector disconnected.</p> <p>The fault is in the wiring between the suspect valve and the ECM P2 connector.</p> <p>Check all of the wiring between the suspect valve and the P2 connector. Refer to the Electrical Schematic for the engine.</p> <p>Replace the faulty wiring.</p> <p>Use the electronic service tool to clear all logged diagnostic codes and verify that the repair eliminates the fault.</p> <p>Result: An XXXX-6 diagnostic code is still active with the P2 connector disconnected.</p> <p>Proceed to Test Step 8.</p>
<p>8. Check if a Replacement ECM Eliminates the Fault</p> <p>A. Contact the Dealer Solution Network (DSN).</p> <p>B. If the DSN recommends the use of a replacement ECM, install a replacement ECM. Refer to Troubleshooting, "Replacing the ECM".</p>	<p>Diagnostic codes</p>	<p>Result: There are no active diagnostic codes with the replacement ECM.</p> <p>Reconnect the suspect ECM. If the fault returns with the suspect ECM, replace the ECM.</p> <p>Use the electronic service tool in order to clear all logged diagnostic codes and then verify that the repair</p>

C. Use the electronic service tool to recheck the system for active diagnostic codes.

eliminates the fault.

Result: The diagnostic code is still present with the replacement ECM.

Contact the DSN.

CAT C3.4B Engine Parts

Contact phone: 269 673 1638

Email: EngineParts@HeavyEquipmentRestorationParts.com

Alternate email: engineparts2@gmail.com

Website: www.CATC34B.com

Related website: www.HeavyEquipmentRestorationParts.com

www.FPTIndustrialEngineParts.com



Previous Screen



Troubleshooting
C3.4B Engines

Media Number -UENR0611-10

Publication Date -01/02/2015

i06042298

NRS Mass Flow Rate Problem

SMCS - 1088-035

This procedure covers the following diagnostic trouble code:

Table 1

Diagnostic Trouble Codes		
J1939 Code	Code Description	Comments
3358-10	Engine Exhaust Gas Recirculation 1 Intake Pressure : Abnormal Rate of Change	The ECM detects an air leak in the Exhaust Gas Recirculation (EGR) system. The warning lamp will flash. The engine may be derated.

Probable Causes

- Diagnostic codes
- Electrical connectors and harness
- Air inlet and exhaust system

Recommended Actions

Note: The procedures have been listed in order of probability. Complete the procedures in order.

Table 2

Troubleshooting Test Steps	Values	Results
1. Diagnostic Codes	Diagnostic	Result: A diagnostic code for

<p>A. Connect the electronic service tool to the diagnostic connector. If necessary, refer to Troubleshooting, "Electronic Service Tools".</p> <p>B. Turn the keyswitch to the ON position.</p> <p>C. Use the electronic service tool to check for active or logged codes.</p>	<p>codes</p>	<p>the EGR valve is active or logged.</p> <p>Rectify the EGR valve code. Refer to Troubleshooting, "Diagnostic Trouble Codes".</p> <p>Result: A 3358-10 diagnostic code is active.</p> <p>Proceed to Test Step 2.</p>
<p>2. Inspect the Electrical Connectors and the Harness</p> <p>A. Turn the keyswitch to the OFF position.</p> <p>B. Inspect the connectors for the components in the EGR system. Refer to Troubleshooting, "Electrical Connector - Inspect".</p> <p>C. Perform a 30 N (6.7 lb) pull test on each of the wires in any suspect connector and the connections at the ECM.</p> <p>D. Check that the ground connection on the ECM and the negative terminal on the battery are correctly installed.</p> <p>E. Check the ground connection on the ECM for abrasions and pinch points.</p> <p>F. Check the harness for abrasion and pinch points from the EGR components to the ECM.</p> <p>H. Check that any suspect connector is installed correctly.</p>	<p>Connectors and harness</p>	<p>Result: An electrical connector or a cable is not correctly installed.</p> <p>Install the connector or cable correctly.</p> <p>Result: The harness is faulty.</p> <p>Install a replacement harness.</p> <p>Result: The harness and connectors are OK.</p> <p>Proceed to Test Step 3.</p>
<p>3. Check the Air Inlet and Exhaust System</p> <p>A. Check the air inlet system for leaks and for restrictions.</p> <p>B. Check the exhaust system for leaks and</p>	<p>Air inlet and exhaust system</p>	<p>Result: The air inlet system has a leak or is restricted.</p> <p>Clear any restrictions in the air inlet system.</p> <p>Repair any air leaks in the air inlet system.</p>

for restrictions.

Result: The exhaust system has a leak or is restricted.

Clear any restrictions in the exhaust system.

Repair any air leaks in the exhaust system.

If the fault is still present, contact the Dealer Solution Network (DSN).

CAT C3.4B Engine Parts

Contact phone: 269 673 1638

Email: EngineParts@HeavyEquipmentRestorationParts.com

Alternate email: engineparts2@gmail.com

Website: www.CATC34B.com

Related website: www.HeavyEquipmentRestorationParts.com

www.FPTIndustrialEngineParts.com



Previous Screen



Troubleshooting
C3.4B Engines

Media Number -UENR0611-10

Publication Date -01/02/2015

i06226001

Oil Consumption Is Excessive

SMCS - 1348-035

Probable Causes

- Misreading oil level
- Oil leaks
- Engine crankcase breather
- Oil level
- Air intake and exhaust system
- Turbocharger
- Low compression (cylinder pressure)

Recommended Actions

Note: The procedures have been listed in order of probability. Complete the procedures in order.

Table 1

Troubleshooting Test Steps	Values	Results
<p>1. Misreading Oil Level</p> <p>A. Accurately measure the consumption of oil and fuel over a period of 50 engine hours.</p>	<p>Oil level</p>	<p>Result: The oil consumption is less than 0.1% of the fuel consumption.</p> <p>Oil consumption is within specification. Return the unit to service</p> <p>Result: The oil consumption is greater than 0.1% of the fuel consumption.</p>

		Proceed to Test Step 2.
<p>2. Oil Leaks</p> <p>A. Check for evidence of oil leaks on the engine.</p> <p>B. Check for evidence of oil in the coolant.</p>	Oil leaks	<p>Result: An oil leak is identified.</p> <p>Repair: Rectify the cause of the oil leak.</p> <p>Result: Oil is present in the coolant.</p> <p>Repair: Refer to Troubleshooting, "Coolant Contains Oil".</p> <p>Result: No oil leaks are identified</p> <p>Proceed to Test Step 3.</p>
<p>3. Engine Crankcase Breather</p> <p>A. Check the engine crankcase breather for blockage or restrictions.</p> <p>B. Check for excessive oil from the outlet of the breather.</p> <p>C. Check the centrifugal breather for a mechanical failure.</p> <p>D. Check for oil around the crankcase breather pressure relief valve.</p>	Breather	<p>Result: The engine crankcase breather is blocked or restricted.</p> <p>Repair: Clear the blockage or restriction.</p> <p>Result: Excessive oil is ejected from the outlet of the breather.</p> <p>Repair: Investigate the cause of the excessive oil content in the breather flow. If necessary, replace the element in the breather. Refer to Operation and Maintenance Manual, "Engine Crankcase Breather Element - Replace".</p> <p>Result: There is oil around the crankcase breather pressure relief valve.</p> <p>Repair: Refer to Troubleshooting, "Crankcase Breather Ejects Oil".</p> <p>Result: No oil is ejected through the breather.</p> <p>Proceed to Test Step 4.</p>
<p>4. Oil Level</p> <p>A. Check for a high oil level in the engine.</p>	Oil level	<p>Result: The oil level in the engine is high.</p> <p>Repair: Make sure that the oil is not contaminated with fuel. Refer to Troubleshooting, "Oil Contains Fuel".</p>

		<p>Make sure that the oil is not contaminated with coolant. Refer to Troubleshooting, "Oil Contains Coolant".</p> <p>Remove the excess oil.</p> <p>Result: The oil level is OK.</p> <p>Proceed to Test Step 5.</p>
<p>5. Air Intake and Exhaust System</p> <p>A. Check the air filter restriction indicator, if equipped.</p> <p>B. Check the air intake and the exhaust system for the following defects:</p> <ul style="list-style-type: none"> · Blockages · Restrictions · Damage to the air intake and exhaust lines and hose 	<p>Air intake and exhaust system</p>	<p>Result: The air filter restriction indicator has operated or the air filter is blocked.</p> <p>Repair: Make sure that the air filter is clean and serviceable. If necessary, replace the air filter.</p> <p>Result: The air intake or the exhaust system is blocked, restricted, or damaged.</p> <p>Repair: Repair the air intake or the exhaust system, as required.</p> <p>Result: The air intake or the exhaust system is OK.</p> <p>Proceed to Test Step 6.</p>
<p>6. Turbocharger</p> <p>Note: The turbocharger that is installed on this engine is a nonserviceable item. If any mechanical fault exists, then the turbocharger must be replaced.</p> <p>A. Check that the oil drain for the turbocharger is not blocked or restricted.</p> <p>B. Check the turbocharger for evidence of an internal oil leak.</p>	<p>Turbocharger</p>	<p>Result: The oil drain for the turbocharger is blocked or restricted.</p> <p>Repair: Remove the blockage or restriction. If necessary, replace the oil drain line.</p> <p>Result: The turbocharger has an internal oil leak.</p> <p>Repair: Replace the turbocharger.</p> <p>Result: The turbocharger is OK.</p> <p>Proceed to Test Step 7.</p>
<p>7. Low Compression (Cylinder Pressure)</p> <p>A. Perform a compression test.</p>	<p>Cylinder compression</p>	<p>Result: The results of the compression test are outside the specifications.</p> <p>Repair: Investigate the cause and rectify</p>

Refer to Systems Operation,
Testing, and Adjusting,
"Compression - Test ".

any faults.

Note: Possible causes of low compression are shown in the following list:

- Loose glow plugs
- Faulty piston
- Faulty piston rings
- Worn cylinder bores
- Worn valves
- Faulty cylinder head gasket
- Damaged cylinder head

Result: The results of the compression test are OK.

Contact the Dealer Solution Network (DSN).

CAT C3.4B Engine Parts

Contact phone: 269 673 1638

Email: EngineParts@HeavyEquipmentRestorationParts.com

Alternate email: engineparts2@gmail.com

Website: www.CATC34B.com

Related website: www.HeavyEquipmentRestorationParts.com

www.FPTIndustrialEngineParts.com



Previous Screen



Troubleshooting
C3.4B Engines

Media Number -UENR0611-10

Publication Date -01/02/2015

i06226024

Oil Contains Coolant

SMCS - 1348-035; 1395-035

Probable Causes

- Engine oil cooler
- Cylinder head gasket
- Cylinder head
- Cylinder block

Recommended Actions

Note: The procedures have been listed in order of probability. Complete the procedures in order.

Table 1

Troubleshooting Test Steps	Values	Results
<p>1. Engine Oil Cooler</p> <p>A. Drain the engine lubricating oil and coolant from the engine. Check for leaks in the oil cooler assembly. Refer to Systems Operation, Testing, and Adjusting, "Cooling System" for the correct procedure.</p>	<p>Oil level</p>	<p>Result: Evidence of coolant in the oil system is identified.</p> <p>Repair: Install a new oil cooler. Refer to Disassembly and Assembly, "Engine Oil Cooler - Remove" and Disassembly and Assembly, "Engine Oil Cooler - Install" for the correct procedure.</p> <p>Result: No evidence of coolant in the oil system is found.</p>

		Proceed to Test Step 2.
<p>2. Cylinder Head Gasket</p> <p>A. Remove the cylinder head. Refer to Disassembly and Assembly, "Cylinder Head - Remove" for the correct procedure. Inspect the cylinder head gasket for faults and any signs of leakage.</p>	Cylinder head gasket	<p>Result: The cylinder head gasket is faulty or shows signs of leakage.</p> <p>Repair: Install a new cylinder head gasket.</p> <p>Result: The cylinder head gasket is OK.</p> <p>Proceed to Test Step 3.</p>
<p>3. Cylinder Head</p> <p>A. Check the cylinder head for flatness. Refer to Systems Operation, Testing, and Adjusting, "Cylinder Head - Inspect" for the correct procedure.</p> <p>B. Check the mating face of the cylinder head for faults and signs of leakage. If a fault is found, replace the cylinder head. If signs of leakage are found, determine the cause of the leakage. Refer to Systems Operation, Testing, and Adjusting, "Cylinder Head - Inspect" for the correct procedure.</p> <p>C. Check the internal core plugs in the cylinder head for signs of leakage.</p>	Cylinder head	<p>Result: The cylinder head is not within specification for flatness.</p> <p>Repair: Install a new cylinder head. Refer to Disassembly and Assembly, "Cylinder Head - Install" for the correct procedure.</p> <p>Result: The cylinder head shows signs of a fault or leakage.</p> <p>Repair: Install a new cylinder head. Refer to Disassembly and Assembly, "Cylinder Head - Install" for the correct procedure.</p> <p>Result: An internal core plug in the cylinder head shows signs of leakage.</p> <p>Repair: Replace the faulty core plug.</p> <p>Result: The cylinder head is OK.</p> <p>Proceed to Test Step 4.</p>
<p>4. Cylinder Block</p> <p>A. Inspect the top face of the cylinder block for faults and signs of leakage.</p>	Cylinder block	<p>Result: The top face of the cylinder block has a fault.</p> <p>Repair: Replace the cylinder block.</p> <p>Result: The top face of the cylinder block shows signs of</p>

leakage.

Repair: Determine the cause of the leakage. Refer to Systems Operation, Testing, and Adjusting, "Cylinder Block - Inspect" for the correct procedure.

Result: The cylinder block is OK.

Repair: Install the cylinder head. Refer to Disassembly and Assembly, "Cylinder Head - Install".

Remove the oil filter element. Install a new engine oil filter element. Fill the engine with clean engine oil to the correct level. Refer to the Operation and Maintenance Manual, "Engine Oil and Filter - Change" for more information.

Fill the cooling system. Refer to the Operation and Maintenance Manual for more information.

Contact the Dealer Solution Network (DSN).

CAT C3.4B Engine Parts

Contact phone: 269 673 1638

Email: EngineParts@HeavyEquipmentRestorationParts.com

Alternate email: engineparts2@gmail.com

Website: www.CATC34B.com

Related website: www.HeavyEquipmentRestorationParts.com

www.FPTIndustrialEngineParts.com



Previous Screen



Troubleshooting
C3.4B Engines

Media Number -UENR0611-10

Publication Date -01/02/2015

i06008534

Oil Contains Fuel

SMCS - 1250-035; 1348-035

This procedure covers the following diagnostic codes:

Table 1

Diagnostic Trouble Codes for Oil Contains Fuel		
J1939 Code	Description	Notes
5055-17	Engine Oil Viscosity : Low - least severe (1)	The Electronic Control Module (ECM) calculates that the amount of fuel in the engine oil is high. If equipped, the warning lamp will come on.
5055-18	Engine Oil Viscosity : Low - moderate severity (2)	The ECM detects that the amount of fuel in the engine oil is very high. If equipped, the warning lamp will flash. The engine will be derated.

The engine ECM calculates the amount of fuel in the engine oil based on the engine operating conditions and the number of Diesel Particulate Filter (DPF) active regenerations since the last time the "Engine Oil Life Reset" was performed.

Note: Before continuing with this procedure, ensure that the engine oil has been changed according to the maintenance schedule. Refer to Operation and Maintenance Manual, "Maintenance Interval Schedule". If the engine oil has been changed, ensure that the "Engine Oil Life Reset" is performed. Refer to Operation and Maintenance Manual, "Engine Oil and Filter - Change".

Measuring Fuel Dilution

Diesel fuel is chemically similar to the lubricants that are used in diesel engines. A slow fuel leak will blend the fuel into the oil. Normal operating temperatures may cause volatile parts of the fuel to vaporize. The fuel that remains in the oil is less volatile.

A closed cup flash test can be performed in order to detect fuel dilution. The flash test is designed to measure the volatile parts of the fuel that are remaining in the oil. Detecting less volatile fuel is difficult. The less volatile fuel reduces the accuracy of the flash test.

Since the flash test does not accurately detect fuel dilution, do not use the flash test as the only measure of fuel dilution. Instead, verify the dilution by the following methods:

- Gas chromatograph fuel dilution test
- Oil viscosity

The test that uses a gas chromatograph is designed to measure fuel dilution in crankcase oils. The gas chromatograph can identify the small chemical differences between diesel fuel and lubricating oil. A gas chromatograph is used to measure fuel dilution at all Caterpillar regional SOS laboratories. Some Cat dealers also use a gas chromatograph. Even though the gas chromatograph provides a more accurate measure of fuel dilution, always verify the results with the viscosity test.

A significant level of fuel dilution reduces oil viscosity. If an unacceptable level of fuel dilution is suspected, the kinematic viscosity of the oil must be measured.

Fuel dilution that is greater than 10 percent will usually cause viscosity that is less than the specified viscosity grade. If the oil is still within the specified viscosity grade, fuel dilution has not reached an unacceptable level.

Verifying Fuel Dilution

Verify fuel dilution by the combination of low oil viscosity and a gas chromatograph that gives a result in excess of 10 percent before investigating or servicing the engine. Ask the Cat dealer to submit an oil sample to a Caterpillar regional SOS laboratory for analysis if a fuel dilution test cannot be performed locally.

Probable Causes

- Diagnostic codes
- Maintenance interval schedule
- Excessive use of active regeneration (wall flow DPF only)
- Fuel injector seals
- Fuel injector tip

Recommended Actions

Note: The procedures have been listed in order of probability. Complete the procedures in order.

Table 2

--	--	--

Troubleshooting Test Steps	Values	Results
<p>1. Diagnostic Codes</p> <p>A. Connect the electronic service tool to the diagnostic connector.</p> <p>B. Use the electronic service tool to check for an active 5055 diagnostic code.</p>	<p>Diagnostic codes</p>	<p>Result: A 5055 diagnostic code is active.</p> <p>Proceed to Test Step 2.</p> <p>Result: A 5055 diagnostic code is not active.</p> <p>Proceed to Test Step 3.</p>
<p>2. Maintenance Interval Schedule</p> <p>A. Use the electronic service tool to check the number of hours since the last "Engine Oil Life Reset" was performed.</p> <p>B. Compare the number of hours since the last "Engine Oil Life Reset" to the maintenance interval for an oil change. Refer to Operation and Maintenance Manual, "Maintenance Interval Schedule".</p>	<p>Greater than oil change interval</p>	<p>Result: The number of hours since the last "Engine Oil Life Reset" is greater than the maintenance interval for an oil change.</p> <p>Change the engine oil and perform the "Engine Oil Life Reset". Refer to Operation and Maintenance Manual, "Engine Oil and Filter - Change".</p> <p>Result: The number of hours since the last "Engine Oil Life Reset" is less than the maintenance interval for an oil change.</p> <p>Proceed to Test Step 3.</p>
<p>3. Excessive Use of Active Regeneration</p> <p>Note: This step is only applicable to engines equipped with a wall flow DPF.</p> <p>A. Excessive use of active regeneration may cause excessive fuel in the engine oil. Refer to Troubleshooting, "Diesel Particulate Filter Active Regeneration Occurrence Is Excessive".</p>	<p>Excessive regeneration</p>	<p>Result: There is excessive use of active regeneration.</p> <p>Make any necessary repairs. Refer to Troubleshooting, "Diesel Particulate Filter Active Regeneration Occurrence Is Excessive".</p> <p>Change the engine oil and perform the "Engine Oil Life Reset". Refer to Operation and Maintenance Manual, "Engine Oil and Filter - Change".</p> <p>Result: There is no excessive use of active regeneration.</p> <p>Proceed to Test Step 4.</p>

<p>4. Fuel Injector Seals</p> <p>A. Check for signs of damage to the seals for the fuel injectors.</p>	<p>Fuel injector seals</p>	<p>Result: Injector seals are damaged.</p> <p>Replace any damaged injector seals.</p> <p>Change the engine oil and perform the "Engine Oil Life Reset". Refer to Operation and Maintenance Manual, "Engine Oil and Filter - Change".</p> <p>Result: All injector seals are OK.</p> <p>Proceed to Test Step 5.</p>
<p>5. Fuel Injector Tip</p> <p>A. Check for signs of damage to the fuel injectors. Check the fuel injector tip for cracks or breakage.</p>	<p>Fuel injector tip</p>	<p>Result: A fuel injector is damaged.</p> <p>Replace the fuel injector. Refer to Disassembly and Assembly, "Electronic Unit Injector - Remove" and Disassembly and Assembly, "Electronic Unit Injector - Install". Change the engine oil and perform the "Engine Oil Life Reset". Refer to Operation and Maintenance Manual, "Engine Oil and Filter - Change".</p> <p>Result: All fuel injectors are OK.</p> <p>Contact the Dealer Solution Network (DSN).</p>

CAT C3.4B Engine Parts
Contact phone: 269 673 1638
Email: EngineParts@HeavyEquipmentRestorationParts.com
Alternate email: engineparts2@gmail.com
Website: www.CATC34B.com
Related website: www.HeavyEquipmentRestorationParts.com
www.FPTIndustrialEngineParts.com



Previous Screen



Troubleshooting
C3.4B Engines

Media Number -UENR0611-10

Publication Date -01/02/2015

i06226085

Oil Pressure Is Low

SMCS - 1348-035-PX

This procedure covers the following diagnostic code:

Table 1

Diagnostic Trouble Codes for Low Engine Oil Pressure		
J1939 Code	Description	Notes
100-17	Engine Oil Pressure : Low - least severe (1)	The Electronic Control Module (ECM) detects that the engine oil pressure is low. The engine speed is greater than 500 RPM. If equipped, the warning lamp will come on and the oil pressure lamp will come on.

NOTICE

Do not operate the engine with low oil pressure. Engine damage will result. If measured oil pressure is low, discontinue engine operation until the fault is corrected.

The Electronic Control Module (ECM) monitors the engine oil pressure.

Probable Causes

- Visible Leaks

- Engine oil level
- Oil specification
- Engine oil filter
- Engine oil pressure switch
- Engine oil relief valve
- Engine oil cooler
- Fuel in the engine oil
- Piston cooling jets
- Engine oil suction tube
- Engine oil pump
- Bearing clearance

Recommended Actions

Note: The procedures have been listed in order of probability. Complete the procedures in order.

Table 2

Troubleshooting Test Steps	Values	Results
<p>1. Visible Leaks</p> <p>A. Thoroughly inspect the engine for oil leaks.</p>	Visible leaks	<p>Result: There are visible oil leaks.</p> <p>Repair: Repair any leaks.</p> <p>Result: There are no visible oil leaks</p> <p>Proceed to Test Step 2.</p>
<p>2. Engine Oil Level</p> <p>A. Check the engine oil level.</p>	Oil level	<p>Result: The engine oil level is low.</p> <p>Repair: Fill the oil system to the full mark on the dipstick.</p> <p>Result: The engine oil level is OK.</p> <p>Proceed to Test Step 3.</p>
<p>3. Oil Specification</p> <p>A. Check that engine oil of the</p>	Oil specification	<p>Result: An incorrect specification of engine oil is being used.</p>

<p>correct specification is being used. Refer to the Operation and Maintenance Manual, "Refill Capacities and Recommendations".</p>		<p>Repair: Drain the oil system and refill the oil system with engine oil of the correct specification. Refer to Operation and Maintenance Manual, "Engine Oil and Filter - Change".</p> <p>Result: The engine contains oil of the correct specification.</p> <p>Proceed to Test Step 4.</p>
<p>4. Engine Oil Filter</p> <p>A. Remove the engine oil filter. Refer to the Operation and Maintenance Manual, "Engine Oil and Filter - Change".</p> <p>B. Inspect the engine oil filter for evidence of blockage.</p>	<p>Oil filter</p>	<p>Result: The oil filter is blocked.</p> <p>Repair: Install a new oil filter. Refer to the Operation and Maintenance Manual, "Engine Oil and Filter - Change" for further information.</p> <p>Result: The oil filter is OK.</p> <p>Repair: Install a new oil filter. Refer to the Operation and Maintenance Manual, "Engine Oil and Filter - Change" for further information.</p> <p>Proceed to Test Step 5.</p>
<p>5. Engine Oil Pressure Switch</p> <p>A. Ensure that the engine oil pressure switch is operating correctly. Refer to Troubleshooting, "Switch Circuits - Test (Engine Oil Pressure Switch)".</p>	<p>Engine Oil Pressure Switch</p>	<p>Result: There is a fault with the oil pressure switch circuit.</p> <p>Repair: Make any necessary repairs. Refer to Troubleshooting, "Switch Circuits - Test (Engine Oil Pressure Switch)".</p> <p>Result: The oil pressure switch circuit is OK.</p> <p>Proceed to Test Step 6.</p>
<p>6. Engine Oil Relief Valve</p> <p>A. Inspect the engine oil relief valve for damage.</p>	<p>Damage</p>	<p>Result: The engine oil relief valve is damaged.</p> <p>Repair: Replace the oil relief valve. Refer to Disassembly and Assembly, "Engine Oil Relief Valve - Remove and Install".</p>

		<p>Result: The engine oil relief valve is OK.</p> <p>Proceed to Test Step 7.</p>
<p>7. Engine Oil Cooler</p> <p>A. Check the oil cooler for signs of damage or restrictions.</p>	Oil cooler	<p>Result: The oil cooler has signs of damage or restriction.</p> <p>Repair: Install a new oil cooler. Refer to Disassembly and Assembly, "Engine Oil Cooler - Remove" and Disassembly and Assembly, "Engine Oil Cooler - Install".</p> <p>Result: The oil cooler is OK.</p> <p>Proceed to Test Step 8.</p>
<p>8. Fuel in the Engine Oil</p> <p>A. Check fuel contamination of the engine oil. Refer to Troubleshooting, "Oil Contains Fuel".</p>	Oil contamination	<p>Result: The oil contains fuel.</p> <p>Repair: Refer to Troubleshooting, "Oil Contains Fuel".</p> <p>Result: The oil is not contaminated.</p> <p>Proceed to Test Step 9.</p>
<p>9. Piston Cooling Jets</p> <p>A. Inspect the piston cooling jets for cracks, damage, or missing jets.</p>	Piston cooling jets	<p>Result: A piston cooling jet is cracked, damaged, or missing.</p> <p>Result: Install a new piston cooling jet. Refer to Disassembly and Assembly, "Piston Cooling Jets - Remove and Install".</p> <p>Result: The piston cooling jets are OK.</p> <p>Proceed to Test Step 10.</p>
<p>10. Engine Oil Suction Tube</p> <p>A. Check the inlet screen on the oil suction tube and remove any material that may be restricting oil flow.</p>	Oil suction tube	<p>Result: The inlet screen on the oil suction tube is blocked with debris.</p> <p>Repair: Remove the debris from the inlet screen.</p>

<p>B. Check the joints of the oil suction tube for cracks or a damaged joint.</p> <p>Note: Cracks or damage may allow air leakage into the supply to the oil pump.</p>		<p>Result: The oil suction tube is cracked.</p> <p>Repair: Install a new oil suction tube.</p> <p>Result: The oil suction tube is OK.</p> <p>Proceed to Test Step 11.</p>
<p>11. Engine Oil Pump</p> <p>A. Inspect the components of the engine oil pump for excessive wear.</p>	<p>Oil pump</p>	<p>Result: A component in the oil pump is not within specification.</p> <p>Repair: Repair the oil pump or replace the oil pump, if necessary. Refer to Disassembly and Assembly, "Engine Oil Pump - Remove" and Disassembly and Assembly, "Engine Oil Pump - Install".</p> <p>Result: The oil pump is OK.</p> <p>Proceed to Test Step 12.</p>
<p>12. Bearing Clearance</p> <p>A. Inspect the engine components for excessive bearing clearance or damaged bearings. Inspect the following components for excessive bearing clearance:</p> <ul style="list-style-type: none"> · Crankshaft main bearings · Connecting rod bearings · Camshaft front bearing · Idler gear bearing 	<p>Bearing clearance</p>	<p>Result: An engine bearing is not within specification.</p> <p>Repair: Install a new bearing. Refer to Disassembly and Assembly.</p> <p>Result: All engine bearings are within specification.</p> <p>Repair: If the fault is still present there may be an open circuit condition in the oil pressure switch circuit. Refer to Troubleshooting, "Switch Circuits - Test (Engine Oil Pressure Switch)".</p>

CAT C3.4B Engine Parts

Contact phone: 269 673 1638

Email: EngineParts@HeavyEquipmentRestorationParts.com

Alternate email: engineparts2@gmail.com

Website: www.CATC34B.com

Related website: www.HeavyEquipmentRestorationParts.com

www.FPTIndustrialEngineParts.com



Previous Screen



Troubleshooting

C3.4B Engines

Media Number -UENR0611-10

Publication Date -01/02/2015

i06015862

Oxygen Level - Test

SMCS - 1096-038

This procedure covers the following diagnostic codes:

Table 1

Diagnostic Trouble Codes for the Oxygen Sensor Circuit		
J1939 Code	Description	Notes
3217-3	Aftertreatment #1 Intake O2 : Voltage Above Normal	The Electronic Control Module (ECM) detects a fault in the circuit for the oxygen sensor.
3217-4	Aftertreatment #1 Intake O2 : Voltage Below Normal	The fault detected is either an open circuit or short circuit in the current pump, the ground, the current adjust or the voltage signal.
3219-15	Aftertreatment #1 Intake Gas Sensor at Temperature : High - least severe (1)	The Electronic Control Module (ECM) detects a fault in the circuit for the oxygen sensor.
3219-17	Aftertreatment #1 Intake Gas Sensor at Temperature : Low - least severe (1)	The fault detected is either an open circuit or short circuit in the current pump, the ground, the current adjust or the voltage signal.
3217-5	Aftertreatment #1 Intake O2 : Current Below Normal	The Electronic Control Module (ECM) detects a fault in the circuit for the oxygen sensor.
3217-6	Aftertreatment #1 Intake O2 : Current Above Normal	The fault detected is either an open circuit or short circuit in the current pump, the ground, the current adjust, the voltage signal or the heater circuit.
3217-13	Aftertreatment #1 Intake O2 : Out of Calibration	The Electronic Control Module (ECM) detects a fault in the circuit for the oxygen sensor.

3217-15	Aftertreatment #1 Intake O2 : High - least severe (1)	The fault detected is either an open circuit or short circuit in the current pump, the ground, the current adjust, the voltage signal or the heater circuit.
3217-12	Aftertreatment #1 Intake O2 : Failure	The ECM is unable to read any valid data from the oxygen sensor.
3222-3	Aftertreatment #1 Intake Gas Sensor Heater : Voltage Above Normal	The ECM detects a short to battery voltage in the heater circuit for the oxygen sensor.
3222-4	Aftertreatment #1 Intake Gas Sensor Heater : Voltage Below Normal	The ECM detects a short to ground in heater circuit for the oxygen sensor.
3222-5	Aftertreatment #1 Intake Gas Sensor Heater : Current Below Normal	The ECM detects an open circuit in the heater circuit for the oxygen sensor.

The oxygen sensor is used to monitor the oxygen in the engine exhaust. The ECM utilizes the signal from the oxygen sensor to ensure that the engine burns the fuel efficiently and reduces excessive build-up of soot in the Diesel Particulate Filter (DPF).

The oxygen sensor generates a voltage signal that is directly proportional to the concentration of oxygen. This voltage signal cannot be measured accurately with a multimeter. The signal can only be interpreted correctly by the software that is contained in the ECM.

A heater circuit within the oxygen sensor ensures that a build-up of condensation does not damage the sensor.

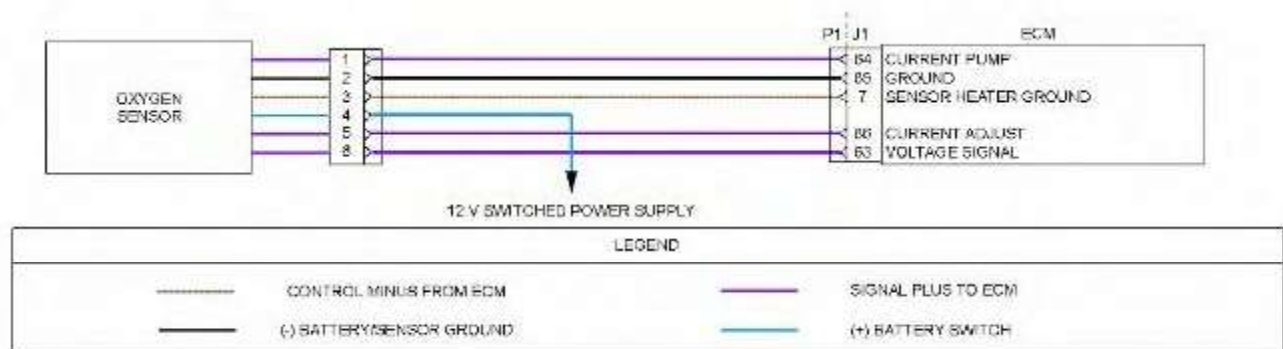

Illustration 1

g03617457

Schematic diagram for the oxygen sensor

Not all connectors are shown. Refer to the Electrical Schematic for the application.

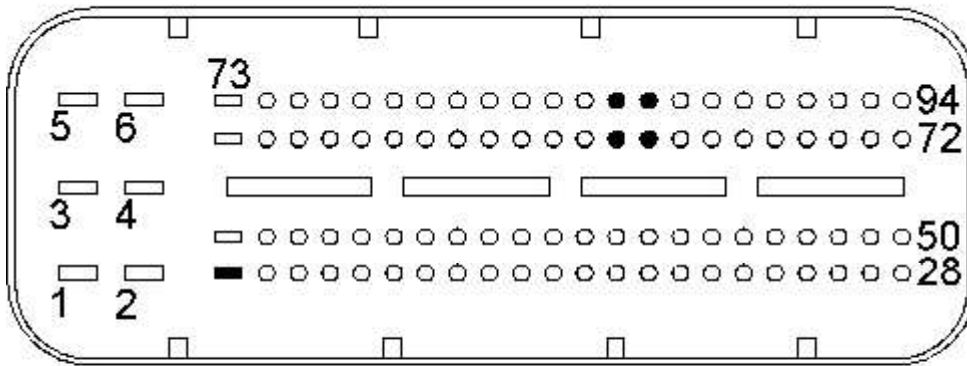

Illustration 2

g02724356

View of the pin locations on the P1 connector for the oxygen sensor

(7) Sensor heating ground

(63) Voltage signal

(64) Current pump

(85) Virtual ground

(86) Current adjust

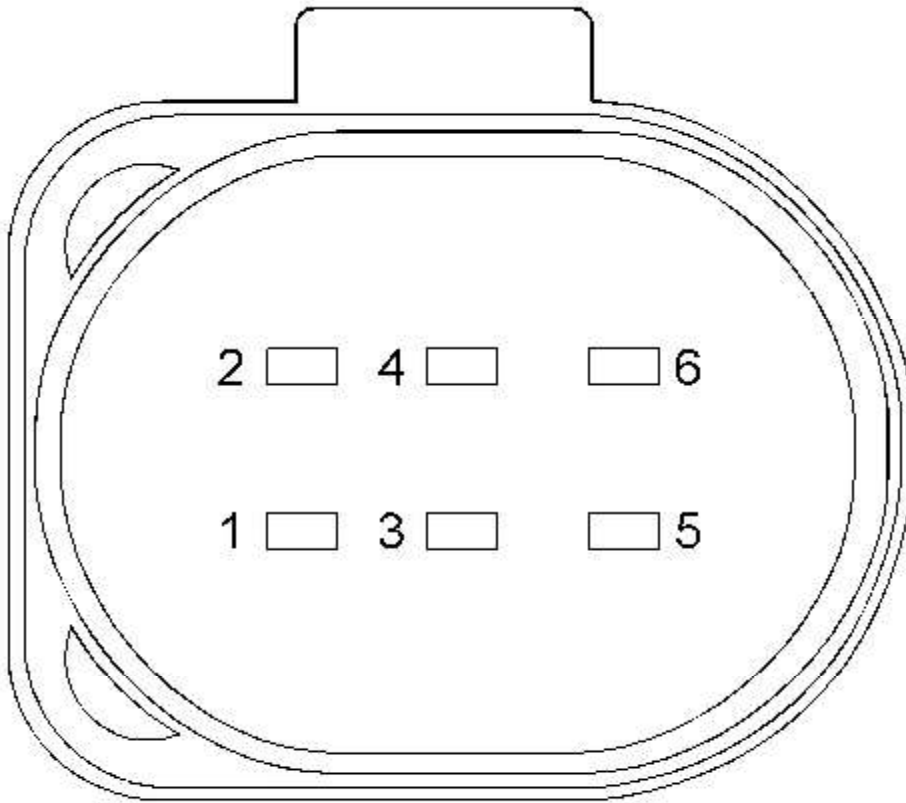

Illustration 3

g03114187

View of the pin locations on the harness connector for the oxygen sensor (view from the front)

- (1) Current pump
- (2) Virtual ground
- (3) Sensor heating ground
- (4) Sensor heating power supply (switched battery +)
- (5) Current adjust
- (6) Voltage signal

Table 2

Troubleshooting Test Steps	Values	Results
<p>1. Check for Active or Recently Logged Diagnostic Codes</p> <p>A. Turn the keyswitch to the OFF position.</p> <p>B. Connect the electronic service tool to the diagnostic connector.</p> <p>C. Turn the keyswitch to the ON position. If the engine will start, run the engine for 15</p>	<p>Diagnostic codes</p>	<p>Result: There are other active or recently logged diagnostic codes that are not listed in this procedure.</p> <p>Troubleshoot all other diagnostic codes before returning to this procedure. Refer to Troubleshooting, "Diagnostic Trouble Codes"</p> <p>Result: Only diagnostic codes that are listed</p>

<p>minutes or until one of the diagnostic codes listed in Table 1 is active.</p> <p>D. Use the electronic service tool to check for active or recently logged diagnostic codes.</p> <p>E. Turn the keyswitch to the OFF position.</p>		<p>in this procedure are active or recently logged.</p> <p>Proceed to Test Step 2.</p>
<p>2. Inspect Electrical Connectors And Wiring</p> <p>A. Check the fuses.</p> <p>B. Thoroughly inspect the connector for the oxygen sensor. Refer to Troubleshooting, "Electrical Connectors - Inspect".</p> <p>C. Thoroughly inspect the P1/J1 ECM connector. Refer to Troubleshooting, "Electrical Connectors - Inspect".</p> <p>D. Perform a 30 N (6.7 lb) pull test on each of the wires in the connectors that are associated with the oxygen sensor.</p> <p>E. Check the harness for abrasions and for pinch points from the oxygen sensor back to the ECM and from the oxygen sensor to the battery supply.</p>	<p>Damaged wire or connector</p>	<p>Result: A damaged wire or damaged connector was found. A fuse is blown.</p> <p>Repair the damaged wire or the damaged connector. Replace any blown fuses Use the electronic service tool in order to clear all logged diagnostic codes. Run the engine for at least 15 minutes and check for active diagnostic codes to ensure that the repair eliminates the fault.</p> <p>Result: All connectors, pins, and sockets are correctly connected and/or inserted and the harness is free of corrosion, of abrasion or of pinch points.</p> <p>Proceed to Test Step 3.</p>
<p>3. Check for Active or Recently Logged Diagnostic Codes</p> <p>A. Turn the keyswitch to the ON position. If the engine will start, run the engine for 15 minutes.</p> <p>B. Use the electronic service tool to check for active diagnostic codes.</p> <p>C. Turn the keyswitch to the OFF position.</p>	<p>Diagnostic codes</p>	<p>Result: One of the following diagnostic codes is active or recently logged:</p> <ul style="list-style-type: none"> · 3217-5 · 3217-6 · 3217-13 · 3217-15 · 3222-3 · 3222-4 · 3222-5 <p>Proceed to Test Step 4.</p> <p>Result: One of the following diagnostic codes is active or recently logged:</p>

		<ul style="list-style-type: none"> · 3217-3 · 3217-4 · 3219-15 · 3219-17 <p>Proceed to Test Step 7.</p> <p>Result: A 3217-12 diagnostic code is active or recently logged.</p> <p>Proceed to Test Step 10.</p>
<p>4. Check the Voltage to the Oxygen Sensor Heater</p> <p>A. Turn the keyswitch to the OFF position.</p> <p>B. Disconnect the oxygen sensor.</p> <p>C. Turn the keyswitch to the ON position.</p> <p>D. Use a suitable multimeter to measure the voltage between pin 4 on the harness connector for the oxygen sensor and a suitable ground.</p> <p>E. Turn the keyswitch to the OFF position.</p>	<p>10 V to 14 V</p>	<p>Result: The measured voltage is not within the expected range.</p> <p>The fault is in the 12 V power supply wiring to the oxygen sensor. Check all the wiring between the oxygen sensor and the battery. Refer to the Electrical Schematic for the application. Repair the faulty wiring or replace the faulty wiring.</p> <p>Use the electronic service tool to clear all logged diagnostic codes. Run the engine for 15 minutes and use the electronic service tool to verify that the repair eliminates the fault.</p> <p>Result: The measured voltage is within the expected range.</p> <p>Proceed to Test Step 5.</p>
<p>5. Check the Resistance of the Oxygen Sensor Heater</p> <p>A. Turn the keyswitch to the OFF position.</p> <p>B. Disconnect the oxygen sensor.</p> <p>C. Measure the resistance between pin 3 and pin 4 on the oxygen sensor.</p> <p>Note: Allow the oxygen sensor to cool before performing this measurement.</p>	<p>2.4 to 4 Ohms</p>	<p>Result: The measured resistance is not within the expected range.</p> <p>Replace the oxygen sensor. Refer to Disassembly and Assembly, "Oxygen Sensor - Remove and Install". Use the electronic service tool to perform the following resets:</p> <ul style="list-style-type: none"> · "Lambda Sensor Replacement Reset" · "Lambda Sensor Learn Reset" · "Lambda Sensor Temperature Learn Reset"

		<p>Use the electronic service tool to clear all logged diagnostic codes. Run the engine for 15 minutes and use the electronic service tool to verify that the repair eliminates the fault.</p> <p>Result: The measured resistance is within the expected range.</p> <p>Proceed to Test Step 6.</p>
<p>6. Check the Sensor Heater Ground Wire</p> <p>A. Turn the keyswitch to the OFF.</p> <p>B. Disconnect the oxygen sensor. Disconnect the P1 connector from the ECM.</p> <p>C. Use a suitable multimeter to measure the resistance between terminal 3 on the harness connector for the oxygen sensor and P1:7.</p>	<p>Less than 5 Ohms</p>	<p>Result: The measured resistance is greater than 5 Ohms.</p> <p>The fault is in the wiring between the oxygen sensor and the ECM. Check all of the wiring between the oxygen sensor and the ECM. Refer to the Electrical Schematic for the application. Repair the faulty wiring or replace the faulty wiring.</p> <p>Use the electronic service tool to clear all logged diagnostic codes. Run the engine for 15 minutes and use the electronic service tool to verify that the repair eliminates the fault.</p> <p>Result: The measured resistance is less than 5 Ohms.</p> <p>If a 3222 diagnostic code is active, proceed to Test Step 10.</p> <p>If a 3217 diagnostic code is active, return all wires to the original configuration and proceed to Test Step 7.</p>
<p>7. Check the Wiring for an Open Circuit</p> <p>A. Turn the keyswitch to the OFF position.</p> <p>B. Disconnect the oxygen sensor. Disconnect the P1 connector.</p> <p>C. Use a suitable multi meter to measure the</p>	<p>Less than 5 Ohms</p>	<p>Result: At least one of the resistance measurements is greater than 5 Ohms. There is an open circuit or high resistance in the wiring between the oxygen sensor connector and the P1 connector. Check all wiring between the oxygen sensor and the ECM. Refer to the Electrical Schematic for the application.</p>

<p>resistance between the following points:</p> <ul style="list-style-type: none"> · Terminal 1 on the oxygen sensor connector to P1:64 · Terminal 2 on the oxygen sensor connector to P1:85 · Terminal 5 on the oxygen sensor connector to P1:86 · Terminal 6 on the oxygen sensor connector to P1:63 		<p>Repair the faulty wiring or replace the faulty wiring. Use the electronic service tool to clear all logged diagnostic codes and verify that the repair eliminates the fault.</p> <p>Result: All resistance measurements are less than 5 Ohms.</p> <p>Proceed to Test Step 8.</p>
<p>8. Check the Wiring for a Short Circuit</p> <p>A. Turn the keyswitch to the OFF position.</p> <p>B. Disconnect the oxygen sensor connector. Disconnect the P1 connector from the ECM.</p> <p>C. Use a suitable multimeter to measure the resistance from each terminal on the harness connector for the oxygen sensor to every other terminal on the harness connector for the oxygen sensor.</p>	<p>Greater than 1 k Ohm</p>	<p>Result: At least one of the resistance measurements is less than 1 k Ohm.</p> <p>There is a short circuit in the wiring between the oxygen sensor connector and the ECM.</p> <p>Check all wiring between the oxygen sensor and the ECM. Refer to the Electrical Schematic for the application.</p> <p>Repair the faulty wiring or replace the faulty wiring. Use the electronic service tool to clear all logged diagnostic codes and verify that the repair eliminates the fault.</p> <p>Result: All resistance measurements are greater than 1 k Ohm.</p> <p>Proceed to Test Step 9.</p>
<p>9. Check if a Replacement Sensor Eliminates the Fault</p> <p>A. Replace the oxygen sensor. Refer to Disassembly and Assembly, "Oxygen Sensor - Remove and Install" for the correct procedure.</p> <p>B. Use the electronic service tool to perform the following resets:</p> <ul style="list-style-type: none"> · "Lambda Sensor Replacement Reset" · "Lambda Sensor Learn Reset" · "Lambda Sensor Temperature Learn" 	<p>Diagnostic codes</p>	<p>Result: The fault is cleared with the replacement sensor installed.</p> <p>Use the electronic service tool to clear all logged diagnostic codes.</p> <p>Result: The fault is still present with the replacement sensor.</p> <p>Install the original sensor and proceed to Test Step 10.</p>

<p>Reset"</p> <p>C. Turn the keyswitch to the ON position. If the engine will start, run the engine for 15 minutes.</p> <p>D. Use the electronic service tool to check for active diagnostic codes that relate to the oxygen sensor.</p> <p>E. Check for active diagnostic codes.</p>		
<p>10. Check if a Replacement ECM Eliminates the Fault</p> <p>A. Contact the Dealer Solution Network (DSN).</p> <p>B. If the DSN recommends the use of a replacement ECM, install a replacement ECM. Refer to Troubleshooting, "Replacing the ECM".</p> <p>C. Use the electronic service tool to recheck the system for active diagnostic codes.</p>	<p>Diagnostic codes</p>	<p>Result: There are no active diagnostic codes with the replacement ECM.</p> <p>Reconnect the suspect ECM. If the fault returns with the suspect ECM, replace the ECM.</p> <p>Use the electronic service tool in order to clear all logged diagnostic codes and then verify that the repair eliminates the fault.</p> <p>Result: The diagnostic code is still present with the replacement ECM.</p> <p>Contact the DSN.</p>

CAT C3.4B Engine Parts
Contact phone: 269 673 1638
Email: EngineParts@HeavyEquipmentRestorationParts.com
Alternate email: engineparts2@gmail.com
Website: www.CATC34B.com
Related website: www.HeavyEquipmentRestorationParts.com
www.FPTIndustrialEngineParts.com



Previous Screen



Troubleshooting

C3.4B Engines

Media Number -UENR061.1-10

Publication Date -01/02/2015

i06226122

Power Is Intermittently Low or Power Cutout Is Intermittent

SMCS - 1000-035-PWR

Note: Use this procedure only if the engine does not shut down completely.

Probable Causes

- Diagnostic codes
- Electrical connectors
- ECM connection
- Fuel system inspection
- Air inlet and exhaust system

Recommended Actions

NOTICE

Do not crank the engine continuously for more than 30 seconds. Allow the starting motor to cool for two minutes before cranking the engine again.

Note: The procedures have been listed in order of probability. Complete the procedures in order.

Troubleshooting Test Steps	Values	Results
<p>1. Diagnostic Codes</p> <p>A. Establish communication between the electronic service tool and the Electronic Control Module (ECM). Refer to Troubleshooting, "Electronic Service Tools", if necessary.</p> <p>B. Use the electronic service tool to check for active diagnostic codes.</p>	Diagnostic codes	<p>Result: There are active or logged codes.</p> <p>Repair: Troubleshoot any codes before continuing with this procedure. Refer to Troubleshooting, "Diagnostic Trouble Codes".</p> <p>Result: There are no active or logged codes.</p> <p>Proceed to Test Step 2.</p>
<p>2. Electrical Connectors</p> <p>A. Check all electrical connectors for damage. Refer to Troubleshooting, "Electrical Connectors - Inspect".</p> <p>B. Make sure that all the connector seals are in place and that the connectors have been correctly installed.</p>	Electrical connectors	<p>Result: An electrical connector is damaged.</p> <p>Repair: Repair the electrical connector or replace the electrical connector.</p> <p>Result: A connector seal is displaced or missing or an electrical connector is not correctly installed.</p> <p>Repair: Repair the electrical connector or replace the electrical connector.</p> <p>Result: All electrical connectors are OK.</p> <p>Proceed to Test Step 3.</p>
<p>3. ECM Connection</p> <p>A. Check that the P2/J2 and P1/J1 connectors are correctly installed.</p> <p>Note: If a fault is suspected with the ECM power or ground connections, refer to Troubleshooting, "Electrical Power Supply - Test".</p>	ECM connection	<p>Result: An ECM connector is not correctly installed.</p> <p>Repair: Repair the electrical connector or replace the electrical connector.</p> <p>Result: Both ECM connectors are correctly installed.</p> <p>Proceed to Test Step 4.</p>

<p>4. Fuel System Inspection</p> <p>A. Check that the fuel shut-off valve is in the OPEN position.</p> <p>B. If the temperature is below 0 °C (32 °F), check for solidified fuel (wax).</p> <p>C. Check for fuel supply lines that are restricted.</p> <p>D. Check that the low-pressure fuel lines are correctly installed.</p> <p>E. Check the pressures in the fuel system. Refer to Systems Operation, Testing, and Adjusting, "Fuel System Pressure - Test"</p> <p>F. Check the diesel fuel for contamination. Refer to Systems Operation, Testing, and Adjusting, "Fuel Quality - Test".</p> <p>G. Check for air in the fuel system. Refer to Systems Operation, Testing, and Adjusting, "Air in Fuel - Test".</p> <p>H. Ensure that the fuel system has been primed. Refer to Systems Operation, Testing, and Adjusting, "Fuel System - Prime".</p>	<p>Fuel System</p>	<p>Result: A defect was found in the fuel system.</p> <p>Repair: Make any necessary repairs.</p> <p>Result: No defects found.</p> <p>Proceed to Test Step 5.</p>
<p>5. Fuel Filters</p> <p>A. Replace the primary fuel filter and the secondary fuel filter. Refer to the Operation and Maintenance Manual, "Fuel System Primary Filter (Water Separator) Element - Replace".</p> <p>B. Run the engine in the conditions that the fault occurred.</p>	<p>Fault cleared</p>	<p>Result: The fault has been rectified.</p> <p>Return the engine to service.</p> <p>Result: The fault is still present.</p> <p>Proceed to Test Step 6.</p>
<p>6. Air Inlet and Exhaust System</p> <p>A. Check the air filter restriction indicator.</p> <p>B. Ensure that the air filter is clean and serviceable</p>	<p>Defects</p>	<p>Result: A defect was found in the air intake or exhaust system.</p> <p>Repair: Make any necessary repairs.</p> <p>Result: No defects found in the air</p>

C. Check the air intake and exhaust systems for the following defects:

- Blockages
- Restrictions
- Damage to lines or hoses

intake or exhaust systems.

Contact the Dealer Solution Network (DSN).

CAT C3.4B Engine Parts

Contact phone: 269 673 1638

Email: EngineParts@HeavyEquipmentRestorationParts.com

Alternate email: engineparts2@gmail.com

Website: www.CATC34B.com

Related website: www.HeavyEquipmentRestorationParts.com

www.FPTIndustrialEngineParts.com



Previous Screen



Troubleshooting

C3.4B Engines

Media Number -UENR0611-10

Publication Date -01/02/2015

i06230595

Power Take-Off - Test

SMCS - 1165-038-ZS; 7332-038

This procedure covers the following diagnostic code:

Table 1

Diagnostic Trouble Codes		
J1939 Code	Code Description	Comments
976-2	PTO Governor State : Erratic, Intermittent, or Incorrect	<p>The Electronic Control Module (ECM) detects one of the following conditions:</p> <p>One of the PTO switches was pressed within 2.5 seconds of the keyswitch being turned on.</p> <p>OR</p> <p>One of the PTO switches was pressed for more than 10 seconds.</p> <p>OR</p> <p>Two PTO switches were pressed at the same time for at least 0.5 seconds.</p> <p>The battery voltage is at least 10 VDC.</p> <p>The warning lamp will come on.</p>
Follow the troubleshooting procedure in order to identify the root cause of the problem.		

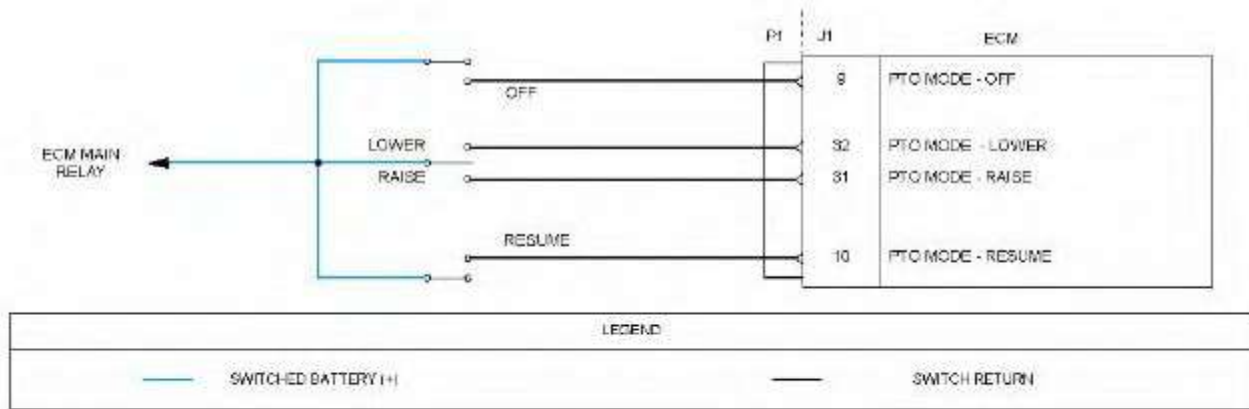

Illustration 1

g03729581

Schematic diagram for the PTO switches

Not all connectors are shown. Refer to the Electrical Schematic for the application.

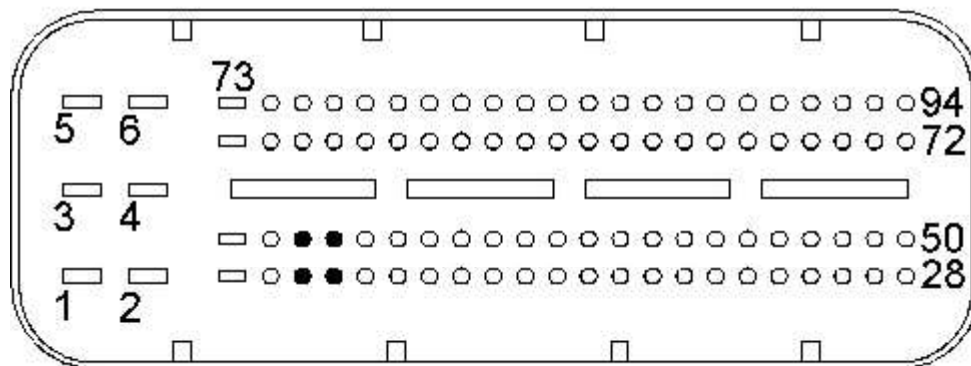

Illustration 2

g02690278

View of the pin locations on the P1 connector for the PTO switches

- (9) PTO mode - OFF
- (10) PTO mode - resume
- (31) PTO mode - raise
- (32) PTO mode - lower

Table 2

Troubleshooting Test Steps	Values	Results
----------------------------	--------	---------

<p>1. Inspect Electrical Connectors and Wiring</p> <p>A. Turn the keyswitch to the OFF position.</p> <p>B. Check the fuses.</p> <p>C. Perform a 30 N (6.7 lb) pull test on each wire in the PTO switch connectors and on each wire in the ECM connector that is associated with the PTO switches.</p> <p>D. Check the harness for corrosion, abrasion, and pinch points from the PTO switches to the ECM and the battery supply.</p>	<p>Damaged wire or connector</p>	<p>Result: A damaged wire or damaged connector was not found. The fuses are OK.</p> <p>Proceed to Test Step 2.</p> <p>Result: A damaged wire or damaged connector was found. A fuse is blown.</p> <p>Repair: Repair the damaged wire or the damaged connector. Replace any blown fuses.</p> <p>Use the electronic service tool to clear all logged diagnostic codes. Verify that the repair eliminates the fault.</p>
<p>2. Check for Active Diagnostic Codes</p> <p>A. Turn the keyswitch to the OFF position.</p> <p>B. Connect the electronic service tool to the diagnostic connector.</p> <p>C. Turn the keyswitch to the ON position.</p> <p>D. Check the "Active Diagnostic Codes" screen. Look for an active or recently logged 976-2 diagnostic code.</p>	<p>Diagnostic Trouble Codes</p>	<p>Result: A 976-2 diagnostic code is active.</p> <p>Proceed to Test Step 3.</p> <p>Result: A 976-2 diagnostic code is recently logged.</p> <p>Repair: The logged code may be caused by operating the PTO switches in one of the conditions that are listed in Table 1 or an intermittent fault may exist. Refer to Troubleshooting, "Electrical Connectors - Inspect" in order to identify intermittent faults.</p> <p>Result: There is no active or recently logged 976-2 diagnostic code.</p> <p>If the switches are not operating correctly, an open circuit may exist. Proceed to Test Step 3.</p>
<p>3. Check the PTO Mode Switches on the Electronic Service Tool</p> <p>A. Turn the keyswitch to the OFF position.</p>	<p>Switch status</p>	<p>Result: The status of each switch changes when the switch is operated.</p> <p>The fault appears to be resolved. Return the engine to service.</p>

<p>B. Connect the electronic service tool to the diagnostic connector.</p> <p>C. Turn the keyswitch to the ON position.</p> <p>D. Observe the status of the PTO switch on the electronic service tool while the PTO on/off switch is cycled.</p> <p>E. Use the electronic service tool in order to observe the status of the PTO mode switch while the PTO lower/raise switch is cycled.</p> <p>F. Use the electronic service tool in order to observe the status of the PTO switch while the PTO Resume switch is cycled.</p>		<p>Result: One of the switches indicates "OPEN" even when the switch is pressed.</p> <p>Proceed to Test Step 4.</p> <p>Result: One of the switches indicates "CLOSED" even when the switch is not pressed.</p> <p>Proceed to Test Step 6.</p>
<p>4. Check the Power Supply to the Suspect Switch</p> <p>A. Turn the keyswitch to the OFF position.</p> <p>B. Disconnect the battery supply wire from the suspect switch.</p> <p>C. Turn the keyswitch to the ON position.</p> <p>D. Check the voltage between the battery supply wire to the suspect switch and a suitable ground.</p>	<p>10 V to 14 V</p>	<p>Result: The measured voltage is within the expected range.</p> <p>Proceed to Test Step 6.</p> <p>Result: The measured voltage is not within the expected range.</p> <p>Proceed to Test Step 5.</p>
<p>5. Check the Wiring Between the Suspect switch and the ECM Main Power Relay</p> <p>A. Turn the keyswitch to the OFF position.</p> <p>B. Disconnect the battery supply wire from the suspect switch.</p> <p>C. Disconnect the ECM main relay.</p>	<p>Less than 5 Ohms</p>	<p>Result: The measured resistance is greater than 5 Ohms.</p> <p>The fault is in the wiring between the suspect switch and the ECM main relay</p> <p>Repair: Check all wiring between the suspect switch and the ECM main relay. Refer to the Electrical Schematic for the application. Replace the faulty wiring.</p> <p>Use the electronic service tool to clear all logged diagnostic codes and verify that the repair eliminates the fault.</p>

<p>D. Use a multimeter to measure the resistance between the disconnected wire and terminal 87 on the harness connector for the ECM main relay.</p>		<p>Result: The measured resistance is less than 5 Ohms.</p> <p>Repair: Refer to Troubleshooting, "Relay - Test (ECM Main Relay)" in order to test the circuit for the ECM main relay.</p>
<p>6. Create at Short Circuit at the Switch</p> <p>A. Turn the keyswitch to the OFF position.</p> <p>B. Disconnect the connector for the suspect switch.</p> <p>C. Fabricate a jumper wire and install the jumper wire between the two terminals for the switch.</p> <p>D. Turn the keyswitch to the ON position.</p> <p>E. Monitor the status screen on the electronic service tool while the jumper wire is being disconnected and reconnected.</p>	<p>Switch status</p>	<p>Result: When the jumper wire is connected, the status of the suspect PTO switch is "CLOSED". When the jumper wire is disconnected, the status of the suspect PTO switch is "OPEN".</p> <p>Repair: Replace the switch. Use the electronic service tool in order to clear all logged diagnostic codes and then verify that the repair has eliminated the problem.</p> <p>Result: When the jumper wire is disconnected, the status of the suspect PTO switch is "CLOSED".</p> <p>Reconnect the switch and proceed to Test Step 7.</p> <p>Result: When the jumper wire is connected, the status of the suspect PTO switch is "OPEN".</p> <p>Proceed to Test Step 8.</p>
<p>7. Check the Switch Return Wire for a Short Circuit</p> <p>A. Turn the keyswitch to the OFF position.</p> <p>B. Disconnect the connector for the suspect switch. Disconnect the P1 connector from the ECM.</p> <p>C. Use a suitable multimeter to measure the resistance between the terminal for the suspect switch on the P1 connector and all</p>	<p>Greater than 1 k Ohm</p>	<p>Result: At least one of the resistance measurements is less than 1 k Ohm. There is a short in the wiring between the suspect switch and the P1 ECM connector.</p> <p>Repair: Check all wiring between the suspect switch and the ECM. Refer to the Electrical Schematic for the application.</p> <p>Replace the faulty wiring. Use the electronic service tool to clear all logged diagnostic codes and verify that the repair eliminates the fault.</p>

<p>other terminals on the P1 connector.</p>		<p>Result: All resistance measurements are greater than 1 k Ohm.</p> <p>Contact the Dealer Solution Network (DSN).</p>
<p>8. Measure the Resistance of the Switch Return Wire to the ECM</p> <p>A. Disconnect the P1 connector from the ECM.</p> <p>B. Thoroughly inspect the J1/P1 connectors on the ECM. Refer to Troubleshooting, "Electrical Connectors - Inspect" for details.</p> <p>C. Measure the resistance between the appropriate pin on the P1 connector for the suspect switch and the wire to the suspect switch. Refer to Illustration 1.</p>	<p>Less than 5 Ohms</p>	<p>Result: The measured resistance is greater than 5 Ohms. The fault is in the wiring between the suspect switch and the P1 connector.</p> <p>Repair: Check all wiring between the suspect switch and the P1 connector. Refer to the Electrical Schematic for the application. Replace the faulty wiring. Use the electronic service tool in order to clear all logged diagnostic codes and then verify that the repair has eliminated the fault.</p> <p>Result: The measured resistance is less than 5 Ohms.</p> <p>Contact the Dealer Solution Network (DSN).</p>

CAT C3.4B Engine Parts
Contact phone: 269 673 1638
Email: EngineParts@HeavyEquipmentRestorationParts.com
Alternate email: engineparts2@gmail.com
Website: www.CATC34B.com
Related website: www.HeavyEquipmentRestorationParts.com
www.FPTIndustrialEngineParts.com



Previous Screen



Troubleshooting

C3.4B Engines

Media Number -UENR061.1-10

Publication Date -01/02/2015

i06230637

Relay - Test - ECM Main Relay

SMCS - 4493-038

This procedure covers the following diagnostic code:

Table 1

Diagnostic Trouble Codes		
J1939 Code	Code Description	Comments
1485-7	ECM Main Relay : Not Responding Properly	<p>The Electronic Control Module (ECM) detects that the battery supply voltage is still present 0.5 seconds after the shut-off request from the ECM.</p> <p>The warning lamp will come on. The ECM is receiving battery voltage after the keyswitch has been turned OFF, which will drain battery power.</p>
1485-14	ECM Main relay : Special Instruction	<p>The ECM requires battery voltage for up to 60 seconds after the keyswitch has been turned OFF.</p> <p>A fault is caused when the ECM has lost battery voltage before this period has elapsed.</p> <p>The fault is detected the next time the keyswitch is turned ON. The diagnostic code becomes active when the fault is detected for three consecutive starts.</p> <p>The warning lamp will come on.</p> <p>This condition is most likely caused by shutting the engine down using the battery disconnect switch instead of the keyswitch for three consecutive shutdowns or using the battery disconnect switch immediately after the keyswitch has been turned OFF.</p>

2840-14

ECU Instance :
Special Instruction

The ECM was unable to write data to the internal memory.

This condition is most likely caused by removing battery power from the ECM while the ECM was attempting to write data to the internal memory.

Follow the troubleshooting procedure in order to identify the root cause of the problem.

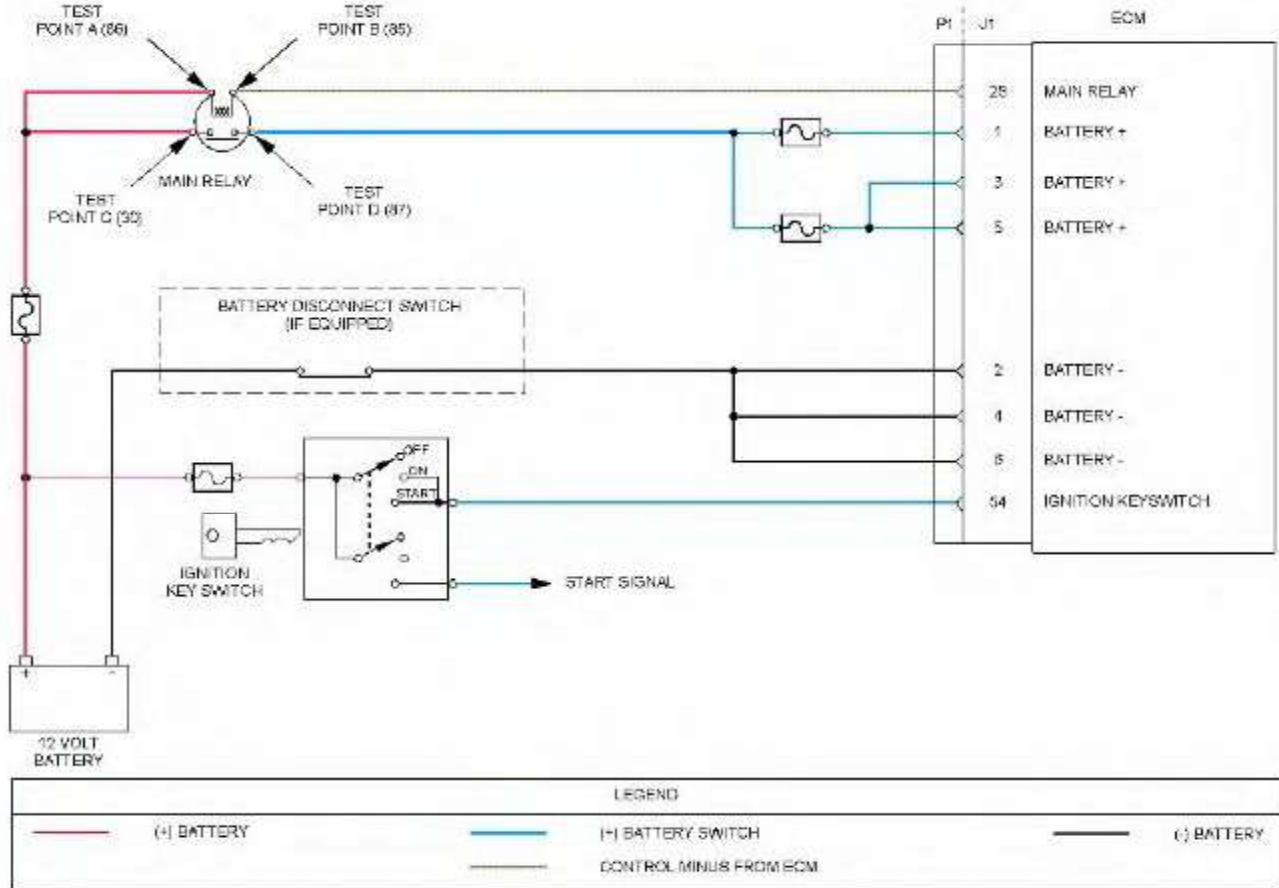

Illustration 1

g03729651

Schematic diagram for the ECM main relay

Not all connectors are shown. Refer to the Electrical Schematic for the application.

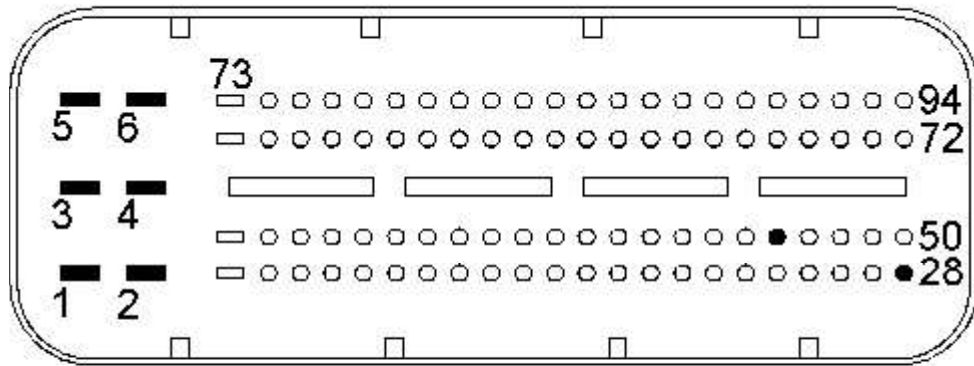

Illustration 2

g02716384

View of the pin locations on the P1 connector for the ignition keyswitch and battery supply circuit

- (1) Battery+
- (2) Battery ground
- (3) Battery+
- (4) Battery ground
- (5) Battery+
- (6) Battery ground
- (28) ECM main relay
- (54) Ignition key switch

Table 2

Troubleshooting Test Steps	Values	Results
<p>1. Inspect Electrical Connectors and Wiring</p> <p>A. Check the fuses.</p> <p>B. Thoroughly inspect the P1/J1 ECM connectors and thoroughly inspect the connector for the ECM main relay. Refer to Troubleshooting, "Electrical Connectors - Inspect" for details.</p> <p>C. Perform a 30 N (6.7 lb) pull test on each of the wires that are associated with the main relay.</p>	<p>Damaged wire or connector</p>	<p>Result: A damaged wire or damaged connector was not found. The fuses are OK.</p> <p>Proceed to Test Step 2.</p> <p>Result: A damaged wire or damaged connector was found. A fuse is blown.</p> <p>Repair: Repair the damaged wire or the damaged connector. Replace any blown fuses. Use the electronic service tool to clear all logged diagnostic codes. Verify that the repair eliminates the fault.</p>

<p>2. Check for Diagnostic Codes</p> <p>A. Turn the keyswitch to the OFF position.</p> <p>B. Connect the electronic service tool to the diagnostic connector.</p> <p>C. Turn the keyswitch to the ON position.</p> <p>D. Monitor the electronic service tool for active diagnostic codes and/or logged diagnostic codes.</p>	<p>Diagnostic Trouble Codes</p>	<p>Result: A 1485-7 diagnostic code is active or recently logged.</p> <p>Proceed to Test Step 3.</p> <p>Result: A 1485-14 or 2840-14 diagnostic code is active or recently logged.</p> <p>Repair: Ensure that the correct procedure is used to shut down the engine. Refer to Operation and Maintenance Manual, "Stopping the Engine". If the engine is being shut down correctly, an intermittent fault may be causing the ECM to lose battery power. Refer to Troubleshooting, "Electrical Power Supply - Test" and refer to Troubleshooting, "Electrical Connectors - Inspect".</p>
<p>3. Check the ECM Main Relay</p> <p>A. Turn the keyswitch to the OFF position.</p> <p>B. Disconnect the ECM main relay.</p> <p>C. Measure the resistance between Test Point C (terminal 30) and Test Point D (terminal 87) on the relay.</p>	<p>Open circuit</p>	<p>Result: The resistance measurement indicates "Open Circuit"</p> <p>Proceed to Test Step 4.</p> <p>Result: The resistance measurement indicates continuity between Test Point C and Test Point D on the relay.</p> <p>Repair: Replace the ECM main relay. Use the electronic service tool to clear all logged diagnostic codes and verify that the repair eliminates the fault.</p>
<p>4. Check the Wiring Between the Relay and the ECM</p> <p>A. Turn the keyswitch to the OFF position.</p> <p>B. Disconnect the ECM main relay. Disconnect the P1 connector.</p> <p>C. Measure the voltage between Test Point A (terminal 86) and Test Point B (terminal 85) on the harness connector</p>	<p>0 V</p>	<p>Result: The voltage measurement is 0 VDC.</p> <p>Contact the Dealer Solution Network (DSN).</p> <p>Result: The voltage measurement indicates battery voltage. The wiring between Test Point B on the harness connector for the relay and P1:28 is shorted to ground.</p> <p>Repair: Check all wiring between the ECM main relay and the P1 connector. Refer to the</p>

for the ECM main relay.

Electrical Schematic for the application.
Replace the faulty wiring.
Use the electronic service tool to clear all
logged diagnostic codes and verify that the
repair eliminates the fault.

If the procedure did not correct the issue, contact the Dealer Solution Network (DSN).

CAT C3.4B Engine Parts

Contact phone: 269 673 1638

Email: EngineParts@HeavyEquipmentRestorationParts.com

Alternate email: engineparts2@gmail.com

Website: www.CATC34B.com

Related website: www.HeavyEquipmentRestorationParts.com

www.FPTIndustrialEngineParts.com



Previous Screen



Troubleshooting

C3.4B Engines

Media Number -UENR0611-10

Publication Date -01/02/2015

i06230630

Relay - Test - Start Relay

SMCS - 4493-038

This procedure covers the following diagnostic code:

Table 1

Diagnostic Trouble Codes for the Starting Motor Relay		
J1939 Code	Description	Notes
677-3	Engine Starter Motor Relay : Voltage Above Normal	The Electronic Control Module (ECM) detects the following conditions: A short circuit to battery in the circuit for the starting motor relay while no start request is detected. The battery voltage is between 9.5 and 16 VDC. The warning lamp will come on. The start relay circuit will be disabled.
677-5	Engine Starter Motor Relay : Current Below Normal	The ECM detects the following conditions: A low current condition on the circuit for the starting motor relay while no start request is detected. The battery voltage is between 9.5 and 16 VDC. The warning lamp will come on. The start relay circuit will be disabled.
677-6	Engine Starter Motor Relay : Current Above Normal	The ECM detects the following conditions: A high current condition (short circuit) in the circuit for the starting motor relay. The battery voltage is between 9.5 and 16 VDC. If equipped, the warning lamp will come on. The engine

		may be derated. The start relay circuit will be disabled.
1041-2	Start Signal Indicator : Erratic, Intermittent, or Incorrect	This diagnostic code indicates that the start signal has remained active for too long. This condition may be caused by the keyswitch being held in the START position for too long. The warning lamp will come on.

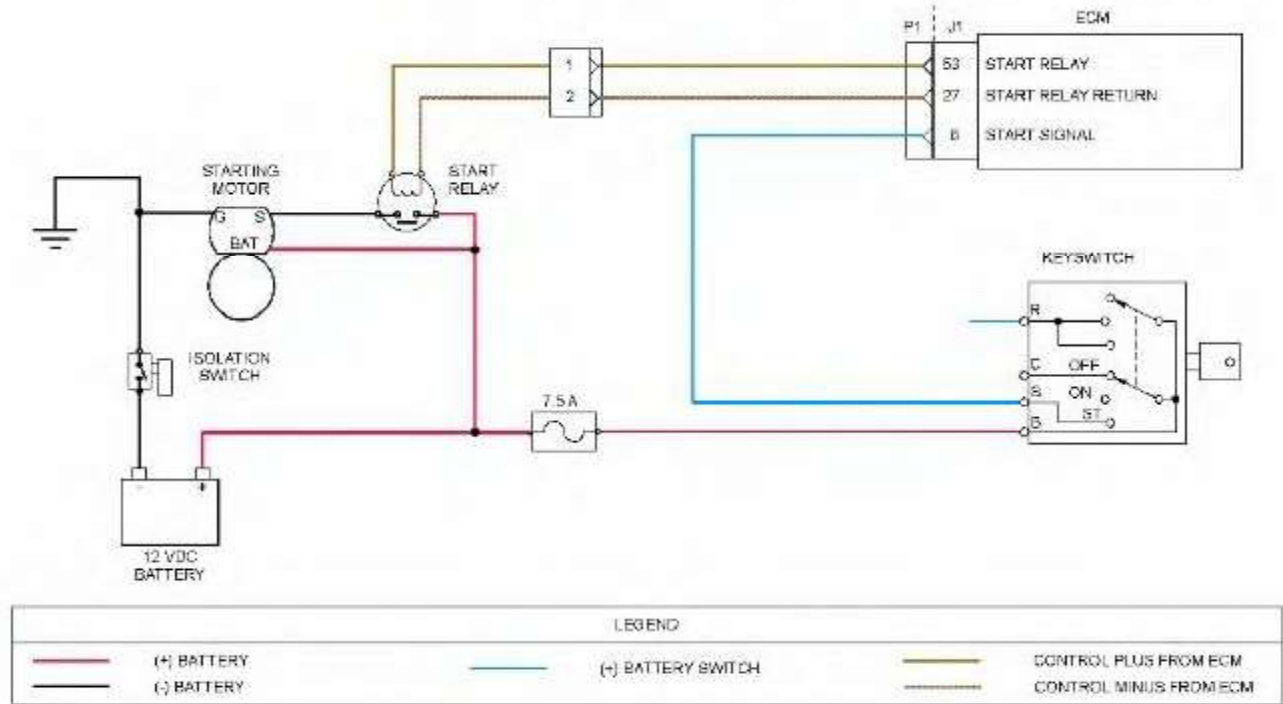

Illustration 1

g03730757

Schematic diagram for the start relay circuit

Not all connectors are shown. Refer to the Electrical Schematic for the application.

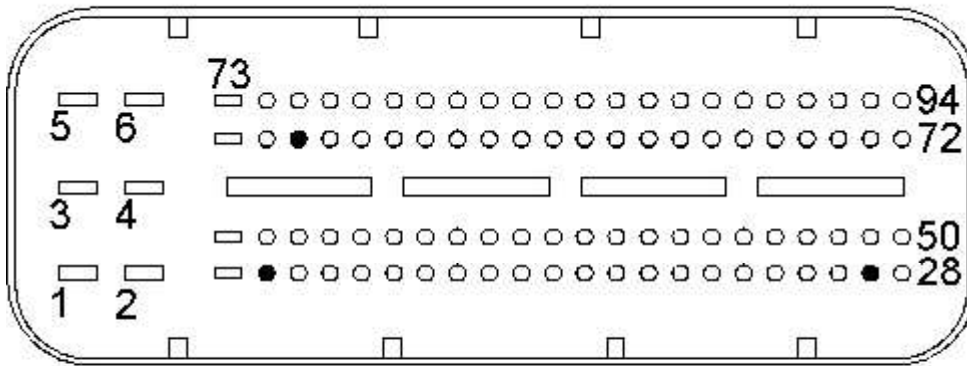

Illustration 2

g02731945

View of the pin locations on the P1 connector for the starting motor relay

- (8) Start signal
- (27) Starting motor relay return
- (53) Starting motor relay control

The following background information is related to this procedure:

When the keyswitch is turned to the START position, a signal is sent to pin P1:8 on the engine ECM. Power is supplied from P1:53 to the starting motor relay.

The starting motor relay supplies battery power to the relay solenoids in the starting motor. This internal relay provides high current battery voltage to the starting motor.

Table 2

Troubleshooting Test Steps	Values	Results
<p>1. Inspect Electrical Connectors and Wiring</p> <p>A. Check the fuses.</p> <p>B. Thoroughly inspect the P1/J1 ECM connectors and thoroughly inspect the connector for the start relay. Refer to Troubleshooting, "Electrical Connector - Inspect" for details.</p> <p>C. Inspect the connections on the starting motor.</p> <p>D. Perform a 30 N (6.7 lb) pull test on each of the</p>	<p>Damaged wire or connector</p>	<p>Result: A damaged wire or damaged connector was not found. The fuses are OK.</p> <p>Proceed to Test Step 2.</p> <p>Result: A damaged wire or damaged connector was found. A fuse is blown.</p> <p>Repair: Repair the damaged wire or the damaged connector. Replace any blown fuses.</p>

wires that are associated with the start relay.		Use the electronic service tool to clear all logged diagnostic codes. Verify that the repair eliminates the fault.
<p>2. Check for Active or Recently Logged Diagnostic Codes</p> <p>A. Connect the electronic service tool to the diagnostic connector.</p> <p>B. If the engine will start, then start the engine.</p> <p>C. Make a note of any active diagnostic codes.</p>	Diagnostic Trouble Codes	<p>Result: Diagnostic code 677-5 is active.</p> <p>Proceed to Test Step 3.</p> <p>Result: Diagnostic code 677-6 or 677-3 is active.</p> <p>Proceed to Test Step 5.</p> <p>Result: A 1041-2 diagnostic code is active or recently logged.</p> <p>If a 1041-2 diagnostic code is recently logged, this may be caused by the keyswitch being held in the START position for too long.</p> <p>If a 1041-2 diagnostic code is active without the keyswitch being held in the START position, proceed to Test Step 9.</p> <p>Result: An active diagnostic code was not displayed.</p> <p>There may be a fault with the start signal from the keyswitch or the power circuit for the starting motor. The ECM does not monitor the status of these conditions.</p> <p>Proceed to Test Step 7.</p>
<p>3. Create a Short Circuit at the Starting Motor Relay</p> <p>A. Turn the keyswitch to the OFF position.</p> <p>B. Disconnect the connector for the starting motor relay.</p>	Diagnostic codes	<p>Result: A 677-6 diagnostic code was active with the jumper installed.</p> <p>Repair: Install a replacement starting motor. Refer to Disassembly and Assembly,</p>

<p>C. Fabricate a jumper wire that is 150 mm (6 inch) long.</p> <p>D. Use the jumper wire to connect pin 1 to pin 2 on the harness connector for the starting motor relay.</p> <p>E. Turn the keyswitch to the ON position.</p> <p>F. Use the electronic service tool to check for an active 677-6 diagnostic code.</p> <p>G. Turn the keyswitch to the OFF position.</p> <p>H. Remove the jumper.</p>		<p>"Electric Starting Motor - Remove and Install".</p> <p>Use the electronic service tool to check for an active 677-5 diagnostic code.</p> <p>Confirm that the fault has been eliminated.</p> <p>Result: A 677-5 diagnostic code is still active with the jumper installed.</p> <p>Reconnect the starting motor relay and proceed to Test Step 4.</p>
<p>4. Check the Wiring Between the Start Relay and the ECM for an Open Circuit</p> <p>A. Turn the keyswitch to the OFF position.</p> <p>B. Disconnect the starting motor relay connector. Disconnect the P1 connector.</p> <p>C. Use a suitable multimeter to measure the resistance between the following points:</p> <ul style="list-style-type: none"> · P1:53 to terminal 1 on the harness connector for the start relay · P1:27 to terminal 2 on the harness connector for the start relay 	<p>Less than 5 Ohms</p>	<p>Result: Each resistance measurement is less than 5 Ohms.</p> <p>Contact the Dealer Solution Network (DSN).</p> <p>Result: At least one of the resistance measurements is greater than 5 Ohms. There is open circuit or high resistance in the wiring between the start relay connector and the P1 connector.</p> <p>Repair: Check all wiring between the start relay connector and the ECM. Refer to the Electrical Schematic for the application. Replace the faulty wiring. Use the electronic service tool to clear all logged diagnostic codes and verify that the repair eliminates the fault.</p>
<p>5. Create an Open Circuit at the Relay</p> <p>A. Turn the keyswitch to the OFF position.</p> <p>B. Disconnect the starting motor relay connector.</p>	<p>Diagnostic codes</p>	<p>Result: A 677-5 diagnostic code became active with the starting motor relay disconnected.</p> <p>Repair: Install a replacement</p>

<p>C. Turn the keyswitch to the ON position.</p> <p>D. Use the electronic service tool to check for an active 677-5 diagnostic code.</p> <p>E. Turn the keyswitch to the OFF position.</p> <p>F. Reconnect the starting motor relay connector.</p>		<p>starting motor. Refer to Disassembly and Assembly, "Electric Starting Motor - Remove and Install".</p> <p>Use the electronic service tool to check for an active 677-5 diagnostic code.</p> <p>Confirm that the fault has been eliminated.</p> <p>Result: A 677-6 diagnostic code is still active with the starting motor relay disconnected.</p> <p>Proceed to Test Step 6.</p>
<p>6. Check the Wiring Between the Start Relay and the ECM for a Short Circuit</p> <p>A. Turn the keyswitch to the OFF position.</p> <p>B. Disconnect the start relay connector. Disconnect the P1 connector from the ECM.</p> <p>C. Use a multimeter to measure the resistance between the following points:</p> <ul style="list-style-type: none"> · P1:53 and all other terminals on the P1 connector · P1:27 and all other terminals on the P1 connector 	<p>Greater than 1 k Ohm</p>	<p>Result: Each resistance measurement is greater than 1 k Ohm.</p> <p>Contact the Dealer Solution Network (DSN).</p> <p>Result: At least one of the resistance measurements is less than 1 k Ohm.</p> <p>There is a short in the wiring between the start relay connector and the P1 connector.</p> <p>Repair: Check all wiring between the start relay connector and the P1 connector. Refer to the Electrical Schematic for the application.</p> <p>Replace the faulty wiring.</p> <p>Use the electronic service tool to clear all logged diagnostic codes and verify that the repair eliminates the fault.</p>
<p>7. Check the Start Signal Wire</p> <p>A. Turn the keyswitch to the OFF position.</p> <p>B. Disconnect the P1 connector from the engine ECM.</p>	<p>10 V to 14 V</p>	<p>Result: The measured voltage is less than 10 V.</p> <p>The fault is in the start signal wiring.</p> <p>Repair: Check all of the start</p>

<p>C. Use a suitable voltmeter to measure between P1:8 and ground.</p> <p>D. With the keyswitch held in the START position, note the voltage on the voltmeter.</p> <p>E. Turn the keyswitch to the OFF position.</p> <p>F. Reconnect the P1 connector to the engine ECM.</p>		<p>signal wiring between the ignition keyswitch and the ECM. Refer to the Electrical Schematic for the application. Replace the faulty wiring. Use the electronic service tool to clear all logged diagnostic codes and verify that the repair eliminates the fault.</p> <p>Result: The measured voltage is within the expected range.</p> <p>Proceed to Test Step 8.</p>
<p>8. Check the Wiring Between the Batteries and the Starting Motor</p> <p>A. Use a voltmeter to check the voltage between the battery+ terminal on the starting motor and a suitable ground on the engine. The voltmeter must read battery voltage. If the reading is less than battery voltage, there is a fault in the wiring between the battery positive terminal and the starting motor.</p> <p>B. Use a voltmeter to check the voltage between the battery+ terminal and the ground terminal on the starting motor. The voltmeter must read battery voltage. If the reading is less than battery voltage, there is a fault in the wiring between the battery negative terminal and the starting motor.</p>	<p>10 V to 14 V</p>	<p>Result: All voltage readings are OK</p> <p>Repair: Replace the starting motor. Refer to Disassembly and Assembly, "Electric Starting Motor - Remove and Install".</p> <p>Result: At least one of the measured voltages is not within the expected range. The fault is in the wiring between the batteries and the starting motor.</p> <p>Repair: Check all wiring between the batteries and the starting motor. Refer to the Electrical Schematic for the application. Replace the faulty wiring. Use the electronic service tool to clear all logged diagnostic codes and verify that the repair eliminates the fault.</p>
<p>9. Check the Start Signal Voltage at the ECM Connector</p> <p>A. Turn the keyswitch to the OFF position.</p>	<p>10 V to 14 V</p>	<p>Result: The voltage is within the expected range.</p> <p>Proceed to Test Step 10.</p>

<p>B. Disconnect the P1 connector from the ECM.</p> <p>C. Turn the keyswitch to the ON position. Do not attempt to start the engine.</p> <p>D. Use a suitable multimeter to measure the voltage between P1:8 and a suitable ground.</p> <p>E. Turn the keyswitch to the OFF position.</p>		<p>Result: There is no voltage present.</p> <p>Contact the Dealer Solution Network (DSN).</p>
<p>10. Check the Start Signal Voltage at the Keyswitch Connector</p> <p>A. Turn the keyswitch to the OFF position.</p> <p>B. Disconnect the electrical connector for the ignition keyswitch.</p> <p>C. Disconnect the wire from the start signal "S" terminal on the connector for the ignition keyswitch.</p> <p>D. Reconnect the electrical connector for the ignition keyswitch.</p> <p>E. Turn the keyswitch to the ON position. Do not attempt to start the engine.</p> <p>F. Use a suitable multimeter to measure the voltage between the start signal "S" terminal on the connector for the ignition keyswitch and a suitable ground.</p>	<p>10 V to 14 V</p>	<p>Result: The measured voltage is within the expected range.</p> <p>Repair: Install a replacement ignition keyswitch. Use the electronic service tool to clear all logged diagnostic codes and verify that the repair eliminates the fault.</p> <p>Result: The measured voltage is not within the expected range. The fault is in the start signal wiring between the ignition keyswitch and the ECM.</p> <p>Repair: Check all wiring between the ignition keyswitch and the ECM. Refer to the Electrical Schematic for the application.</p> <p>Replace the faulty wiring. Use the electronic service tool to clear all logged diagnostic codes and verify that the repair eliminates the fault.</p>

If the procedure did not correct the issue, Contact the Dealer Solution Network (DSN).



Previous Screen



Troubleshooting

C3.4B Engines

Media Number -UENR0611-10

Publication Date -01/02/2015

i06017538

Sensor Signal (Analog, Active) - Test - Exhaust Gas Pressure Sensor

SMCS - 1439-038

This procedure covers the following codes:

Table 1

Diagnostic Trouble Codes for the Engine Pressure Sensors		
J1939 Code	Description	Notes
1209-3	Engine Exhaust Gas Pressure : Voltage Above Normal	<p>The ECM detects the following conditions:</p> <p>The signal voltage from the exhaust gas pressure sensor is greater than 4.74 VDC for at least 1.8 seconds. The battery voltage is at least 10 VDC.</p> <p>The ECM will use the default value for exhaust gas pressure while this code is active. The default value is 50 kPa (7.25 psi).</p> <p>The engine will be derated.</p>
1209-4	Engine Exhaust Gas Pressure : Voltage Below Normal	<p>The ECM detects the following conditions:</p> <p>The signal voltage from the exhaust gas pressure sensor is less than 0.4 VDC for at least 1.8 seconds. The battery voltage is at least 10 VDC.</p> <p>The ECM will use the default value for exhaust gas pressure while this code is active. The default value is 50 kPa (7.25 psi).</p>

The engine will be derated.

The following conditions must exist before any of the above codes will become active:

- There are no active 3509 codes.
- There are no active 168 codes.

The following background information is related to this procedure:

The 5 VDC sensor supply provides power to all 5 VDC sensors. The ECM supplies 5.0 ± 0.1 VDC to each of the pressure sensor connectors. The sensor supply is output short circuit protected. A short circuit to the battery will not damage the circuit inside the ECM.

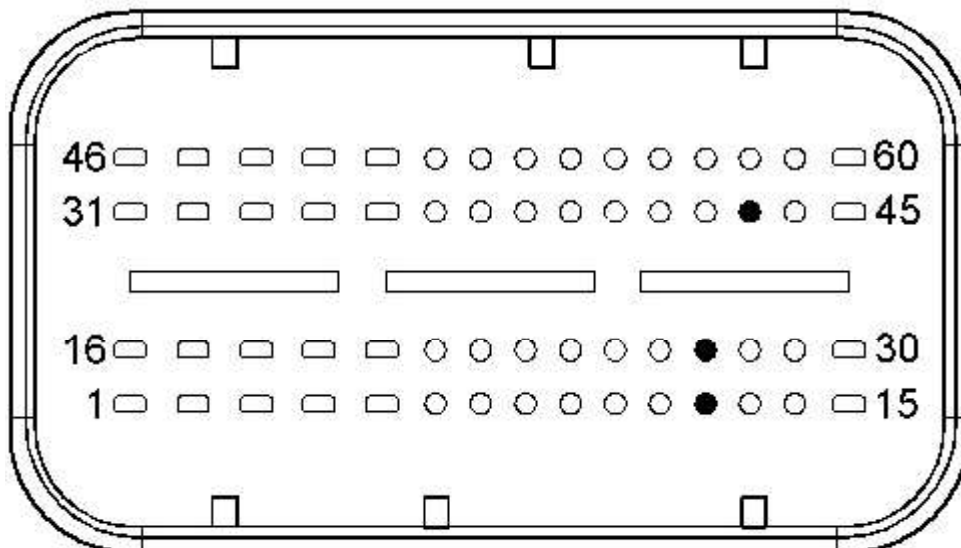

Illustration 1

g03622560

Schematic diagram for the exhaust gas pressure sensor

Not all connectors are shown. Refer to the Electrical Schematic for the application.



Typical view of the pin locations on the P2 connector for the pressure sensors

- (12) Exhaust gas pressure sensor 5 VDC supply
- (27) Exhaust gas pressure sensor ground
- (43) Exhaust gas pressure sensor signal

Table 2

Troubleshooting Test Steps	Values	Results
<p>1. Inspect Electrical Connectors and Wiring</p> <p>A. Thoroughly inspect the terminal connections on the P2/J2 ECM connector. Refer to Troubleshooting, "Electrical Connectors - Inspect".</p> <p>B. Thoroughly inspect the connector for the exhaust gas pressure sensor. Refer to Troubleshooting, "Electrical Connectors - Inspect".</p> <p>C. Perform a 30 N (6.7 lb) pull test on each of the wires in the ECM connector and the sensor connectors that are associated with the exhaust gas pressure sensor.</p> <p>D. Check the harness for abrasions and for pinch points from the exhaust gas pressure sensor back to the ECM.</p>	<p>Damaged wire or connector</p>	<p>Result: A damaged wire or damaged connector was found. A fuse is blown.</p> <p>Repair the damaged wire or the damaged connector. Replace any blown fuses Use the electronic service tool to clear all logged diagnostic codes. Verify that the repair eliminates the fault.</p> <p>Result: All connectors, pins, and sockets are correctly connected and/or inserted and the harness is free of corrosion, of abrasion or of pinch points.</p> <p>Proceed to Test Step 2.</p>
<p>2. Check For Active Diagnostic Codes</p> <p>A. Turn the keyswitch to the ON position. Wait at least 10 seconds for activation of the diagnostic codes.</p> <p>B. Verify if any of the diagnostic codes that are listed in Table 1 are active.</p>	<p>Diagnostic codes</p>	<p>Result: None of the preceding diagnostic codes are active.</p> <p>If the codes in Table 1 are logged, an intermittent condition may be causing the logged codes. Refer to Troubleshooting, "Electrical Connectors - Inspect".</p> <p>Result: A 1209-3 or a 1209-4 diagnostic code is active.</p> <p>Proceed to Test Step 3.</p>

<p>3. Check the Supply Voltage at the Sensor Connector</p> <p>A. Turn the keyswitch to the OFF position.</p> <p>B. Disconnect the connector for the exhaust gas pressure sensor.</p> <p>C. Turn the keyswitch to the ON position. Do not start the engine.</p> <p>D. Measure the voltage between terminal 1 and terminal 2 on the harness connector for the exhaust gas pressure sensor. The voltage measurement should be 5.0 ± 0.1 VDC.</p> <p>E. Turn the keyswitch to the OFF position.</p> <p>F. Reconnect the sensor.</p>	<p>4.9 V to 5.1 V</p>	<p>Result: The voltage measurement is not within the expected range.</p> <p>The fault is in the wiring between the exhaust gas pressure sensor and the P2 ECM connector. Check all wiring between the sensor and the ECM. Refer to the appropriate Electrical Schematic.</p> <p>Replace the faulty wiring. Use the electronic service tool in order to clear all logged diagnostic codes and then verify that the repair eliminates the fault.</p> <p>Result: The voltage measurement is within the expected range.</p> <p>Proceed to Test Step 4.</p>
<p>4. Verify the Type of Active Diagnostic Code</p> <p>A. Turn the keyswitch to the ON position. Wait at least 10 seconds for activation of the diagnostic codes.</p> <p>B. Use the electronic service tool to check for active diagnostic codes. Record all active diagnostic codes.</p> <p>C. Determine if the fault is related to an open circuit diagnostic code or a short circuit diagnostic code.</p>	<p>Diagnostic codes</p>	<p>Result: A 1209-3 diagnostic code is active.</p> <p>Proceed to Test Step 5.</p> <p>Result: A 1209-4 diagnostic code is active.</p> <p>Proceed to Test Step 7.</p> <p>Result: Neither of the preceding diagnostic codes are active.</p> <p>An intermittent fault may exist. Refer to Troubleshooting, "Electrical Connectors - Inspect" in order to identify intermittent faults.</p>
<p>5. Create An Open Circuit at the Sensor Connector</p> <p>A. Turn the keyswitch to the OFF position.</p> <p>B. Disconnect the connector for the exhaust gas pressure sensor.</p>	<p>Diagnostic codes</p>	<p>Result: A 1209-4 diagnostic code became active after disconnecting the sensor.</p> <p>Temporarily connect a new exhaust gas pressure sensor to the harness, but do not install the new sensor in the engine. Use the electronic service tool in order to verify that the repair eliminates the fault and then permanently install the new</p>

<p>C. Turn the keyswitch to the ON position. Wait for at least 10 seconds for activation of the diagnostic codes.</p> <p>D. Use the electronic service tool to check the "Active Diagnostic Code" screen. Check for an active 1209-4 diagnostic code.</p>		<p>sensor.</p> <p>Use the electronic service tool in order to clear all logged diagnostic codes.</p> <p>Clear all logged diagnostic codes.</p> <p>Result: The 1209-3 diagnostic code is still active with the exhaust gas pressure sensor disconnected.</p> <p>Proceed to Test Step 6.</p>
<p>6. Create an Open Circuit at the ECM Connector</p> <p>A. Turn the keyswitch to the OFF position.</p> <p>B. Disconnect the P2 connector from the ECM.</p> <p>C. Turn the keyswitch to the ON position. Wait at least 30 seconds for activation of the diagnostic codes. Note: Diagnostic codes for all of the engine sensors will be active with the P2 connector disconnected. Ignore all other diagnostic codes and only look for a 1209 diagnostic code.</p> <p>D. Access the "Active Diagnostic Codes" screen on the electronic service tool and check for an active 1209-4 diagnostic code for the suspect sensor.</p> <p>E. Turn the keyswitch to the OFF position.</p>	<p>Diagnostic Codes</p>	<p>Result: A 1209-4 diagnostic code became active after the P2 connector was disconnected.</p> <p>The fault is in the wiring between the exhaust gas pressure sensor and the P2 ECM connector. Check all wiring between the sensor and the ECM. Refer to the appropriate Electrical Schematic.</p> <p>Replace the faulty wiring.</p> <p>Use the electronic service tool to clear all logged diagnostic codes and verify that the repair eliminates the fault.</p> <p>Result: The 1209-3 diagnostic code is still active with the P2 connector disconnected.</p> <p>Proceed to Test Step 9.</p>
<p>7. Create a Short at the Sensor Connector</p> <p>A. Turn the keyswitch to the OFF position.</p> <p>B. Disconnect the connector for the exhaust gas pressure sensor.</p>	<p>Diagnostic codes</p>	<p>Result: A 1209-3 diagnostic code was active with the jumper installed.</p> <p>Temporarily connect a new exhaust gas pressure sensor to the harness, but do not install the new sensor in the engine. Use the electronic service tool in order to verify that the repair eliminates the fault and then permanently install the new sensor.</p>

<p>C. Fabricate a jumper wire that is 150 mm (6 inch) long. Install the jumper wire between terminal 1 and terminal 3 on the harness connector for the exhaust gas pressure sensor.</p> <p>D. Turn the keyswitch to the ON position. Wait at least 10 seconds for activation of the diagnostic codes.</p> <p>E. Use the electronic service tool to check for an active 1209-3 diagnostic code for the suspect sensor.</p> <p>F. Turn the keyswitch to the OFF position. Remove the jumper wire.</p>		<p>Use the electronic service tool to clear all logged diagnostic codes and verify that the repair eliminates the fault.</p> <p>Result: A 1209-4 diagnostic code is still active with the jumper installed.</p> <p>Proceed to Test Step 8.</p>
<p>8. Create a Short Circuit at the ECM</p> <p>A. Turn the keyswitch to the OFF position.</p> <p>B. Disconnect the P2 connector from the ECM.</p> <p>C. Fabricate a jumper wire that is 150 mm (6 inch) long. Install the jumper wire between J2:43 and J2:12 .</p> <p>D. Turn the keyswitch to the ON position. Wait at least 10 seconds for activation of the diagnostic codes. Note: Diagnostic codes for all of the engine sensors will be active with the P2 connector disconnected. Ignore all other diagnostic codes. Only look for a 1209 diagnostic code.</p> <p>E. Use the electronic service tool to check for an active 1209-3 diagnostic code for the suspect sensor.</p> <p>F. Turn the keyswitch to the OFF position. Remove the jumper wire.</p>	<p>Diagnostic codes</p>	<p>Result: A 1209-3 diagnostic code was active with the jumper installed.</p> <p>The fault is in the wiring between the exhaust gas pressure sensor and the P2 ECM connector. Check all wiring between the sensor and the ECM. Refer to the appropriate Electrical Schematic. Replace the faulty wiring. Use the electronic service tool to clear all logged diagnostic codes and verify that the repair eliminates the fault.</p> <p>Result: A 1209-4 diagnostic code is still active with the jumper installed.</p> <p>Proceed to Test Step 9.</p>
<p>9. Check if a Replacement ECM</p>	<p>Diagnostic</p>	<p>Result: There are no active diagnostic codes</p>

<p>Eliminates the Fault</p> <p>A. Contact the Dealer Solution Network (DSN).</p> <p>B. If the DSN recommends the use of a replacement ECM, install a replacement ECM. Refer to Troubleshooting, "Replacing the ECM".</p> <p>C. Use the electronic service tool to recheck the system for active diagnostic codes.</p>	<p>codes</p>	<p>with the replacement ECM.</p> <p>Reconnect the suspect ECM. If the fault returns with the suspect ECM, replace the ECM. Use the electronic service tool in order to clear all logged diagnostic codes and then verify that the repair eliminates the fault.</p> <p>Result: The diagnostic code is still present with the replacement ECM.</p> <p>Contact the DSN.</p>
--	--------------	---

CAT C3.4B Engine Parts
Contact phone: 269 673 1638
Email: EngineParts@HeavyEquipmentRestorationParts.com
Alternate email: engineparts2@gmail.com
Website: www.CATC34B.com
Related website: www.HeavyEquipmentRestorationParts.com
www.FPTIndustrialEngineParts.com



Previous Screen



Troubleshooting

C3.4B Engines

Media Number -UENR0611-10

Publication Date -01/02/2015

i06017448

Sensor Signal (Analog, Active) - Test

SMCS - 1439-038

Note: This procedure is applicable to all engine pressure sensors except the exhaust gas pressure sensor.

This procedure covers the following codes:

Table 1

Diagnostic Trouble Codes for the Engine Pressure Sensors		
J1939 Code	Description	Notes
102-3	Engine Intake Manifold #1 Pressure : Voltage Above Normal	<p>The Electronic Control Module (ECM) detects the following conditions:</p> <p>The signal voltage from the intake manifold air pressure sensor is greater than 4.92 VDC for at least 0.5 seconds. The battery voltage is at least 10 VDC.</p> <p>The ECM will use the default value for the intake manifold air pressure while this code is active. The default value is 50 kPa (7.25 psi).</p> <p>The engine will be derated.</p>
102-4	Engine Intake Manifold #1 Pressure : Voltage Below Normal	<p>The ECM detects the following conditions:</p> <p>The signal voltage from the intake manifold air pressure sensor is less than 0.2 VDC for at least 0.5 seconds. The battery voltage is at least 10 VDC.</p>

		<p>The ECM will use the default value for the intake manifold air pressure while this code is active. The default value is 50 kPa (7.25 psi).</p> <p>The engine will be derated.</p>
108-3	Barometric Pressure : Voltage Above Normal	<p>The ECM detects that the signal voltage from the barometric pressure sensor is greater than 4.9 VDC for at least 0.8 seconds. The barometric pressure sensor is contained within the ECM.</p> <p>The ECM will use the default value for the barometric pressure while this code is active. The default value is 97 kPa (14 psi).</p>
108-4	Barometric Pressure : Voltage Below Normal	<p>The ECM detects that the signal voltage from the barometric pressure sensor is less than 0.2 VDC for at least 0.8 seconds. The barometric pressure sensor is contained within the ECM.</p> <p>The ECM will use the default value for the barometric pressure while this code is active. The default value is 97 kPa (14 psi).</p>
157-3	Engine Injector Metering Rail #1 Pressure : Voltage Above Normal	<p>The ECM detects that the signal voltage from the fuel rail pressure sensor is greater than 4.9 VDC for at least 0.2 seconds.</p> <p>The engine will be derated. The engine may shut down.</p>
157-4	Engine Injector Metering Rail #1 Pressure : Voltage Below Normal	<p>The ECM detects that the signal voltage from the intake manifold air pressure sensor is less than 0.34 VDC for at least 0.2 seconds.</p> <p>The engine will be derated. The engine may shut down.</p>
157-10	Engine Injector Metering Rail #1 Pressure : Abnormal Rate of Change	<p>The ECM detects the following conditions:</p> <p>An implausible rate of change in the signal from the fuel rail pressure sensor. The condition has been detected five times within 3 seconds. There are no other active diagnostic codes for the fuel rail pressure sensor.</p> <p>This diagnostic code indicates an intermittent connection in the circuit for the fuel rail pressure sensor.</p>
3251-3	Particulate Trap Differential Pressure : Voltage Above Normal	<p>The ECM detects that the signal voltage from the Diesel Particulate Filter (DPF) differential pressure sensor is greater than 4.87 VDC for at least 1.8 seconds.</p> <p>The ECM will use the default value for the DPF differential pressure while this code is active. The default value is -0.1 kPa (-0.01 psi).</p>

		If equipped, the warning lamp will flash. The engine will be derated.
3251-4	Particulate Trap Differential Pressure : Voltage Below Normal	<p>The ECM detects that the signal voltage from the DPF differential pressure sensor is less than 0.2 VDC for 1.8 seconds.</p> <p>The ECM will use the default value for the DPF differential pressure while this code is active. The default value is -0.1 kPa (-0.01 psi).</p> <p>If equipped, the warning lamp will flash. The engine will be derated.</p>
102-20	Engine Intake Manifold #1 Pressure : Data Drifted High	<p>The ECM detects the following conditions:</p> <p>The intake manifold pressure is greater than 7 kPa (1 psi) above the barometric pressure for at least 5 seconds.</p> <p>The engine is not cranking.</p> <p>The battery voltage is greater than 10 VDC.</p> <p>The engine will be derated.</p>
102-21	Engine Intake Manifold #1 Pressure : Data Drifted Low	<p>The ECM detects the following conditions:</p> <p>The intake manifold pressure is greater than 7 kPa (1 psi) below the barometric pressure for at least 5 seconds.</p> <p>The engine is not cranking.</p> <p>The battery voltage is greater than 10 VDC.</p> <p>The engine will be derated.</p>

The following conditions must exist before any of the above codes will become active:

- There are no active 3509 codes.
- There are no active 168 codes.

The following background information is related to this procedure:

The 5 VDC sensor supply provides power to all 5 VDC sensors. The ECM supplies 5.0 ± 0.1 VDC to each of the pressure sensor connectors. The sensor supply is output short circuit protected. A short circuit to the battery will not damage the circuit inside the ECM.

Pull-up Voltage

The ECM continuously outputs a pull-up voltage on the circuit for the sensor signal wire. This pull-up voltage is required for correct sensor operation and diagnostics.

When the sensor is disconnected, this pull-up voltage can be measured at the harness connector for the sensor.

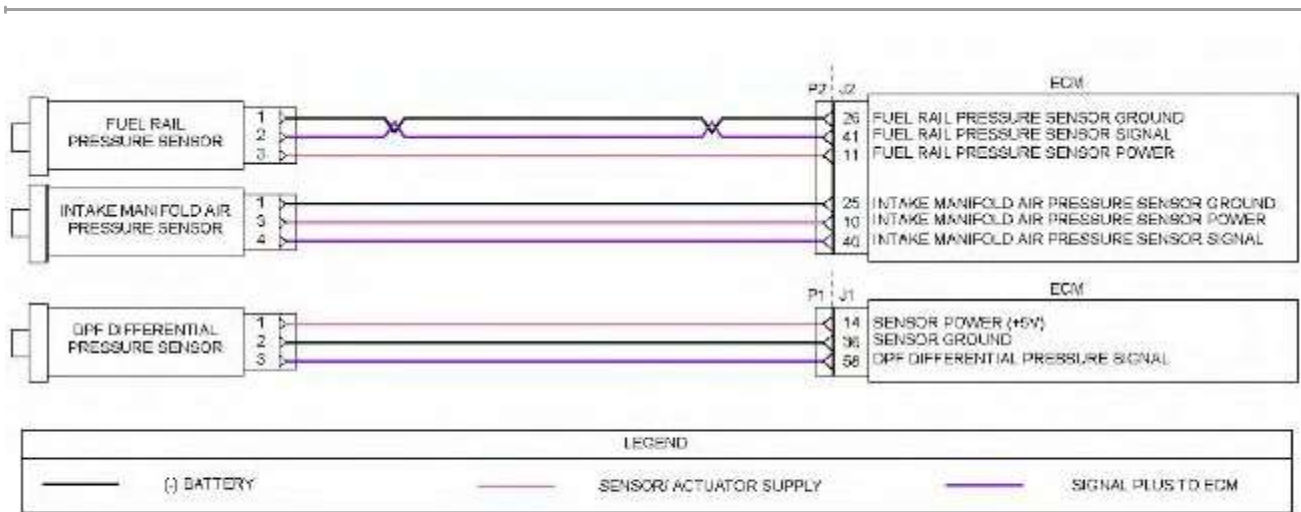

Illustration 1

g03774823

Schematic diagram for the engine pressure sensors

Not all connectors are shown. Refer to the Electrical Schematic for the application.

Note: The DPF differential pressure sensor is installed on engines equipped with a wall flow DPF only.

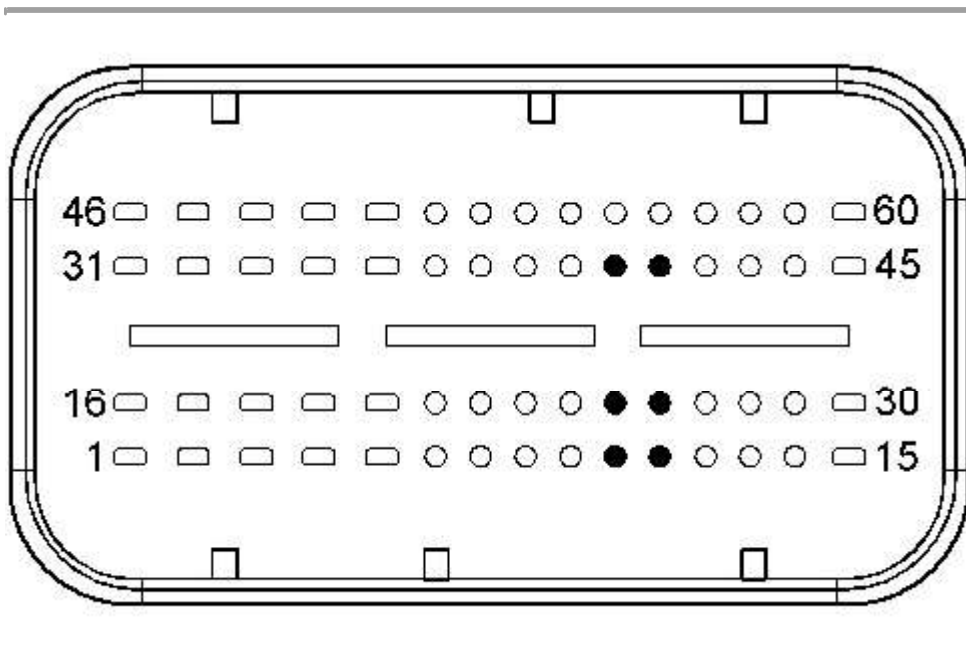

Typical view of the pin locations on the P2 connector for the pressure sensors

- (10) Intake manifold air pressure sensor 5 VDC supply
- (11) Fuel rail pressure sensor 5 VDC supply
- (25) Intake manifold air pressure sensor ground
- (26) Fuel rail pressure sensor ground
- (40) Intake manifold air pressure sensor signal
- (41) Fuel rail pressure sensor signal

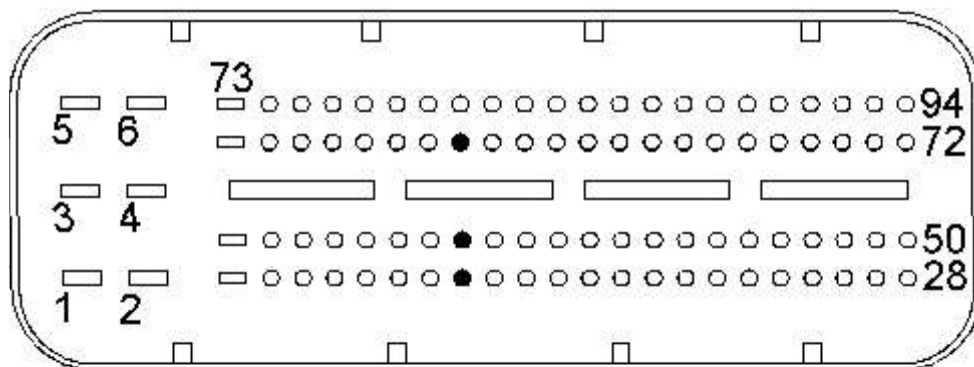

Typical view of the pin locations on the P1 connector for the DPF differential pressure sensor

- (14) DPF differential sensor 5 VDC supply
- (36) DPF differential pressure sensor ground
- (58) DPF differential pressure sensor signal

Table 2

Troubleshooting Test Steps	Values	Results
<p>1. Inspect Electrical Connectors and Wiring</p> <p>A. Thoroughly inspect the terminal connections on the P2/J2 and P1/J1 ECM connectors. Refer to Troubleshooting, "Electrical Connectors - Inspect".</p> <p>B. Thoroughly inspect the connectors for the engine pressure sensors. Refer to Troubleshooting, "Electrical Connectors -</p>	<p>Damaged wire or connector</p>	<p>Result: A damaged wire or damaged connector was found.</p> <p>Repair the damaged wire or the damaged connector. Replace any blown fuses Use the electronic service tool to clear all logged diagnostic codes. Verify that the repair eliminates the fault.</p> <p>Result: All connectors, pins, and sockets are correctly connected and/or inserted and the</p>

<p>Inspect".</p> <p>C. Perform a 30 N (6.7 lb) pull test on each of the wires in the ECM connector and the sensor connectors that are associated with the exhaust gas pressure sensor.</p> <p>D. Check the harness for abrasions and for pinch points from the exhaust gas pressure sensor back to the ECM.</p>		<p>harness is free of corrosion, of abrasion or of pinch points.</p> <p>Proceed to Test Step 2.</p>
<p>2. Check For Active Diagnostic Codes</p> <p>A. Turn the keyswitch to the ON position. Wait at least 10 seconds for activation of the diagnostic codes.</p> <p>B. Verify if any of the diagnostic codes that are listed in Table 1 are active.</p>	<p>Diagnostic codes</p>	<p>Result: A 108-3 or 108-4 diagnostic code is active.</p> <p>Proceed to Test Step 9.</p> <p>Result: An XXXX-3 or an XXXX-4 diagnostic code is active for one or more of the other pressure sensors. A 102-20 or 102-21 diagnostic code is active.</p> <p>Proceed to Test Step 3.</p> <p>Result: A 157-10 diagnostic code is active or recently logged.</p> <p>An intermittent connection exists in the circuit for the fuel rail pressure sensor. Refer to Troubleshooting, "Electrical Connectors - Inspect" in order to identify intermittent connections.</p>
<p>3. Check the Supply Voltage at the Sensor Connector</p> <p>A. Turn the keyswitch to the OFF position.</p> <p>B. Disconnect the connector for the suspect sensor.</p> <p>C. Turn the keyswitch to the ON position. Do not start the engine.</p> <p>D. Measure the voltage between the 5</p>	<p>4.9 V to 5.1 V</p>	<p>Result: The voltage measurement is not within the expected range.</p> <p>The fault is in the wiring between the suspect sensor and the P2 ECM connector. Repair the faulty wiring or replace the faulty wiring. Use the electronic service tool in order to clear all logged diagnostic codes and then verify that the repair eliminates the fault.</p> <p>Result: The voltage measurement is within the expected range.</p>

<p>VDC supply terminal and the ground terminal on the harness connector for the suspect sensor. The voltage measurement should be 5.0 ± 0.1 VDC.</p> <p>E. Turn the keyswitch to the OFF position.</p> <p>F. Reconnect the sensor.</p>		<p>Proceed to Test Step 4.</p>
<p>4. Verify the Type of Active Diagnostic Code</p> <p>A. Turn the keyswitch to the ON position. Wait at least 10 seconds for activation of the diagnostic codes.</p> <p>B. Use the electronic service tool to check for active diagnostic codes. Record all active diagnostic codes.</p> <p>C. Determine if the fault is related to an open circuit diagnostic code or a short circuit diagnostic code.</p>	<p>Diagnostic codes</p>	<p>Result: An XXXX-4 diagnostic code is active for one or more of the pressure sensors at this time.</p> <p>Proceed to Test Step 5.</p> <p>Result: An XXXX-3 diagnostic code is active for one or more of the pressure sensors at this time.</p> <p>Proceed to Test Step 7.</p> <p>Result: None of the preceding diagnostic codes are active.</p> <p>An intermittent fault may exist. Refer to Troubleshooting, "Electrical Connectors - Inspect" in order to identify intermittent faults.</p>
<p>5. Create An Open Circuit at the Sensor Connector</p> <p>A. Turn the keyswitch to the OFF position.</p> <p>B. Disconnect the connector for the sensor with the XXXX-4 diagnostic code.</p> <p>C. Turn the keyswitch to the ON position. Wait for at least 10 seconds for activation of the diagnostic codes.</p> <p>D. Use the electronic service tool to check the "Active Diagnostic Code" screen. Check for an XXXX-3 diagnostic</p>	<p>Diagnostic codes</p>	<p>Result: An XXXX-3 diagnostic code became active after disconnecting the sensor.</p> <p>Temporarily connect a new sensor to the harness, but do not install the new sensor in the engine. Use the electronic service tool in order to verify that the repair eliminates the fault and then permanently install the new sensor.</p> <p>If the fuel rail is replaced, use the electronic service tool to perform the "Rail Pressure Valve Learn Reset".</p> <p>Use the electronic service tool in order to clear all logged diagnostic codes.</p> <p>Result: The XXXX-4 diagnostic code is still</p>

<p>code for the suspect sensor.</p>		<p>active with the sensor disconnected.</p> <p>Proceed to Test Step 6.</p>
<p>6. Create an Open Circuit at the ECM Connector</p> <p>A. Turn the keyswitch to the OFF position.</p> <p>B. Disconnect the P2 connector from the ECM.</p> <p>C. Turn the keyswitch to the ON position. Wait at least 30 seconds for activation of the diagnostic codes. Note: Diagnostic codes for all of the engine sensors will be active with the P2 connector disconnected. Ignore all other diagnostic codes and only look for codes relating to the suspect sensor.</p> <p>D. Access the "Active Diagnostic Codes" screen on the electronic service tool and check for an active XXXX-3 diagnostic code for the suspect sensor.</p> <p>E. Turn the keyswitch to the OFF position.</p>	<p>Diagnostic Codes</p>	<p>Result: An XXXX-3 diagnostic code for the suspect sensor became active after the P2 connector was disconnected.</p> <p>The fault is in the wiring between the suspect sensor and the P2 ECM connector. Check all wiring between the suspect sensor and the ECM. Refer to the appropriate Electrical Schematic. Replace the faulty wiring. Use the electronic service tool to clear all logged diagnostic codes and verify that the repair eliminates the fault.</p> <p>Result: The XXXX-4 diagnostic code for the suspect sensor is still active with the P2 connector disconnected.</p> <p>Proceed to Test Step 9.</p>
<p>7. Create a Short at the Sensor Connector</p> <p>A. Turn the keyswitch to the OFF position.</p> <p>B. Disconnect the connector for the suspect sensor.</p> <p>C. Fabricate a jumper wire that is 150 mm (6 inch) long. Install the jumper wire between the sensor signal terminal and the sensor ground terminal on the harness connector for the suspect sensor.</p> <p>D. Turn the keyswitch to the ON position.</p>	<p>Diagnostic codes</p>	<p>Result: An XXXX-4 diagnostic code was active with the jumper installed.</p> <p>Temporarily connect a new pressure sensor to the harness, but do not install the new sensor in the engine. Use the electronic service tool in order to verify that the repair eliminates the fault and then permanently install the new sensor. If the fuel rail is replaced, use the electronic service tool to perform the "Rail Pressure Valve Learn Reset". Use the electronic service tool to clear all logged diagnostic codes and verify that the repair eliminates the fault.</p>

<p>Wait at least 10 seconds for activation of the diagnostic codes.</p> <p>E. Use the electronic service tool to check for an active XXXX-4 diagnostic code for the suspect sensor.</p> <p>F. Turn the keyswitch to the OFF position. Remove the jumper wire.</p>		<p>Result: An XXXX-3 diagnostic code is still active with the jumper installed.</p> <p>Proceed to Test Step 8.</p>
<p>8. Create a Short Circuit at the ECM</p> <p>A. Turn the keyswitch to the OFF position.</p> <p>B. Disconnect the P2 connector from the ECM.</p> <p>C. Fabricate a jumper wire that is 150 mm (6 inch) long. Install the jumper wire between the suspect sensor signal pin and the sensor ground pin on the J2 connector.</p> <p>D. Turn the keyswitch to the ON position. Wait at least 10 seconds for activation of the diagnostic codes. Note: Diagnostic codes for all of the engine sensors will be active with the P2 connector disconnected. Ignore all other diagnostic codes. Only look for codes that relate to the suspect sensor.</p> <p>E. Use the electronic service tool to check for an active XXXX-4 diagnostic code for the suspect sensor.</p> <p>F. Turn the keyswitch to the OFF position. Remove the jumper wire.</p>	<p>Diagnostic codes</p>	<p>Result: An XXXX-3 diagnostic code was active with the jumper installed.</p> <p>The fault is in the wiring between the suspect sensor and the P2 ECM connector. Check all wiring between the suspect sensor and the ECM. Refer to the appropriate Electrical Schematic. Replace the faulty wiring. Use the electronic service tool to clear all logged diagnostic codes and verify that the repair eliminates the fault.</p> <p>Result: An XXXX-3 diagnostic code is still active with the jumper installed.</p> <p>Proceed to Test Step 9.</p>
<p>9. Check if a Replacement ECM Eliminates the Fault</p> <p>A. Contact the Dealer Solution Network (DSN).</p>	<p>Diagnostic codes</p>	<p>Result: There are no active diagnostic codes with the replacement ECM.</p> <p>Reconnect the suspect ECM. If the fault returns with the suspect ECM, replace the ECM.</p>

B. If the DSN recommends the use of a replacement ECM, install a replacement ECM. Refer to Troubleshooting, "Replacing the ECM".

C. Use the electronic service tool to recheck the system for active diagnostic codes.

Use the electronic service tool in order to clear all logged diagnostic codes and then verify that the repair eliminates the fault.

Result: The diagnostic code is still present with the replacement ECM.

Contact the DSN.

CAT C3.4B Engine Parts

Contact phone: 269 673 1638

Email: EngineParts@HeavyEquipmentRestorationParts.com

Alternate email: engineparts2@gmail.com

Website: www.CATC34B.com

Related website: www.HeavyEquipmentRestorationParts.com

www.FPTIndustrialEngineParts.com



Previous Screen



Troubleshooting

C3.4B Engines

Media Number -UENR0611-10

Publication Date -01/02/2015

i06019084

Sensor Signal (Analog, Passive) - Test

SMCS - 1439-038

This procedure covers the following codes:

Table 1

Diagnostic Trouble Codes for the Engine Temperature Sensors		
J1939 Code	Description	Notes
105-3	Engine Intake Manifold #1 Temperature : Voltage Above Normal	<p>The Electronic Control Module (ECM) detects the following conditions:</p> <p>The signal voltage for the intake manifold temperature sensor is greater than 4.94 VDC for at least 0.5 seconds. The battery voltage is at least 10 VDC. The ECM will use a default value for the intake manifold temperature while this diagnostic code is active.</p> <p>The engine will be derated.</p>
105-4	Engine Intake Manifold #1 Temperature : Voltage Below Normal	<p>The ECM detects the following conditions:</p> <p>The signal voltage for the intake manifold temperature sensor is less than 0.26 VDC for at least 0.5 seconds. The battery voltage is at least 10 VDC.</p> <p>The ECM will use a default value for the intake manifold temperature while this diagnostic code is active.</p> <p>The engine will be derated.</p>

110-3	Engine Coolant Temperature : Voltage Above Normal	<p>The ECM detects that the signal voltage for the coolant temperature sensor is greater than 4.93 VDC for at least 0.5 seconds.</p> <p>The ECM will use the default value for the coolant temperature while this diagnostic code is active. The default value is -10° C (14° F) at engine start, gradually increasing to 90° C (194° F) as the engine is running.</p> <p>The engine will be derated.</p>
110-4	Engine Coolant Temperature : Voltage Below Normal	<p>The ECM detects that the signal voltage for the coolant temperature sensor is less than 0.2 VDC for at least 0.5 seconds.</p> <p>The ECM will use the default value for the coolant temperature while this diagnostic code is active. The default value is -10° C (14° F) at engine start, gradually increasing to 90° C (194° F) as the engine is running.</p> <p>The engine will be derated.</p>
172-3	Engine Air Inlet Temperature : Voltage Above Normal	<p>The ECM detects that the signal voltage for the air inlet temperature sensor is greater than 4.9 VDC for at least 0.5 seconds.</p> <p>While this code is active, the ECM will gradually increase or decrease the air inlet temperature from the last valid reading until the default value is reached. The default value is 30° C (86° F).</p>
172-4	Engine Air Inlet Temperature : Voltage Below Normal	<p>The ECM detects that the signal voltage for the air inlet temperature sensor is less than 0.2 VDC for at least 0.5 seconds.</p> <p>While this code is active, the ECM will gradually increase or decrease the air inlet temperature from the last valid reading until the default value is reached. The default value is 30° C (86° F).</p>
173-3	Engine Exhaust Gas Temperature : Voltage Above Normal	<p>The ECM detects the following conditions:</p> <p>The signal from the exhaust gas temperature sensor is greater than 3.6 VDC for at least 1 second. The battery voltage is at least 10 VDC.</p> <p>While this code is active, the ECM will use the default value for the exhaust gas temperature. The default value is 350° C (662° F).</p>

		The engine will be derated.
173-4	Engine Exhaust Gas Temperature : Voltage Below Normal	<p>The ECM detects that the signal from the exhaust gas temperature sensor is less than 0.46 VDC for at least 1 second.</p> <p>While this code is active, the ECM will use the default value for the exhaust gas temperature. The default value is 350° C (662° F).</p> <p>The engine will be derated.</p>
174-3	Engine Fuel Temperature 1 : Voltage Above Normal	<p>The ECM detects that the signal voltage for the fuel temperature sensor is greater than 4.9 VDC for at least 0.5 seconds.</p> <p>The ECM will use a default value for the fuel temperature while this code is active. The default value will be based on the coolant temperature. If the coolant temperature sensor has an active fault, the default value for the fuel temperature is 40° C (104° F).</p>
174-4	Engine Fuel Temperature 1 : Voltage Below Normal	<p>The ECM detects that the signal voltage for the fuel temperature sensor is less than 0.2 VDC for at least 0.5 seconds.</p> <p>The ECM will use a default value for the fuel temperature while this code is active. The default value will be based on the coolant temperature. If the coolant temperature sensor has an active fault, the default value for the fuel temperature is 40° C (104° F).</p>
3242-0	Particulate Trap Intake Gas Temperature : High - most severe (3)	<p>The ECM detects that the temperature signal from the Diesel Particulate Filter (DPF) inlet temperature sensor is implausibly high.</p> <p>The warning lamp will flash. The shutdown lamp will come on. The engine will be shut down.</p>
3242-3	Particulate Trap Intake Gas Temperature : Voltage Above Normal	<p>The ECM detects that the signal voltage for the Diesel Particulate Filter (DPF) inlet temperature sensor is greater than 3.6 VDC for at least 1 second.</p> <p>The ECM will use the default value for the DPF inlet temperature while this code is active. The default temperature is 100° C (212° F).</p> <p>The engine will be derated.</p>
3242-4		The ECM detects that the signal voltage for the DPF inlet temperature sensor is less than 0.46 VDC for at least 1 second.

	Particulate Trap Intake Gas Temperature : Voltage Below Normal	The ECM will use the default value for the DPF inlet temperature while this code is active. The default temperature is 100° C (212° F). The engine will be derated.
4765-3	Aftertreatment #1 Diesel Oxidation Catalyst Intake Gas Temperature : Voltage Above Normal	The ECM detects that the signal voltage for the Diesel Oxidation Catalyst (DOC) inlet temperature sensor is greater than 3.6 VDC for at least 1 second. The ECM will use the default value for the DOC inlet temperature sensor while this code is active. The default value is 80° C (176° F).
4765-4	Aftertreatment #1 Diesel Oxidation Catalyst Intake Gas Temperature : Voltage Below Normal	The ECM detects that the signal voltage for the DOC inlet temperature sensor is less than 0.46 VDC for at least 1 second. The ECM will use the default value for the DOC inlet temperature sensor while this code is active. The default value is 80° C (176° F).

This procedure covers open circuit diagnostic codes and short circuit diagnostic codes that are associated with the following sensors:

- Intake manifold temperature sensor
- Coolant temperature sensor
- Exhaust gas temperature sensor
- Fuel temperature sensor
- Air inlet temperature sensor
- DOC inlet temperature sensor
- DPF inlet temperature sensor

The following background information is related to this procedure:

The troubleshooting procedures for the diagnostic codes of each temperature sensor are identical. The temperature sensors have two terminals. The signal voltage from each sensor is supplied to the appropriate terminal in the P2/J2 connector or the P1/J1 connector.

Pull-up Voltage

The ECM continuously outputs a pull-up voltage on the circuit for the sensor signal wire. This pull-up voltage is required for correct sensor operation and diagnostics.

When the sensor is disconnected, this pull-up voltage can be measured at the harness connector for the sensor.

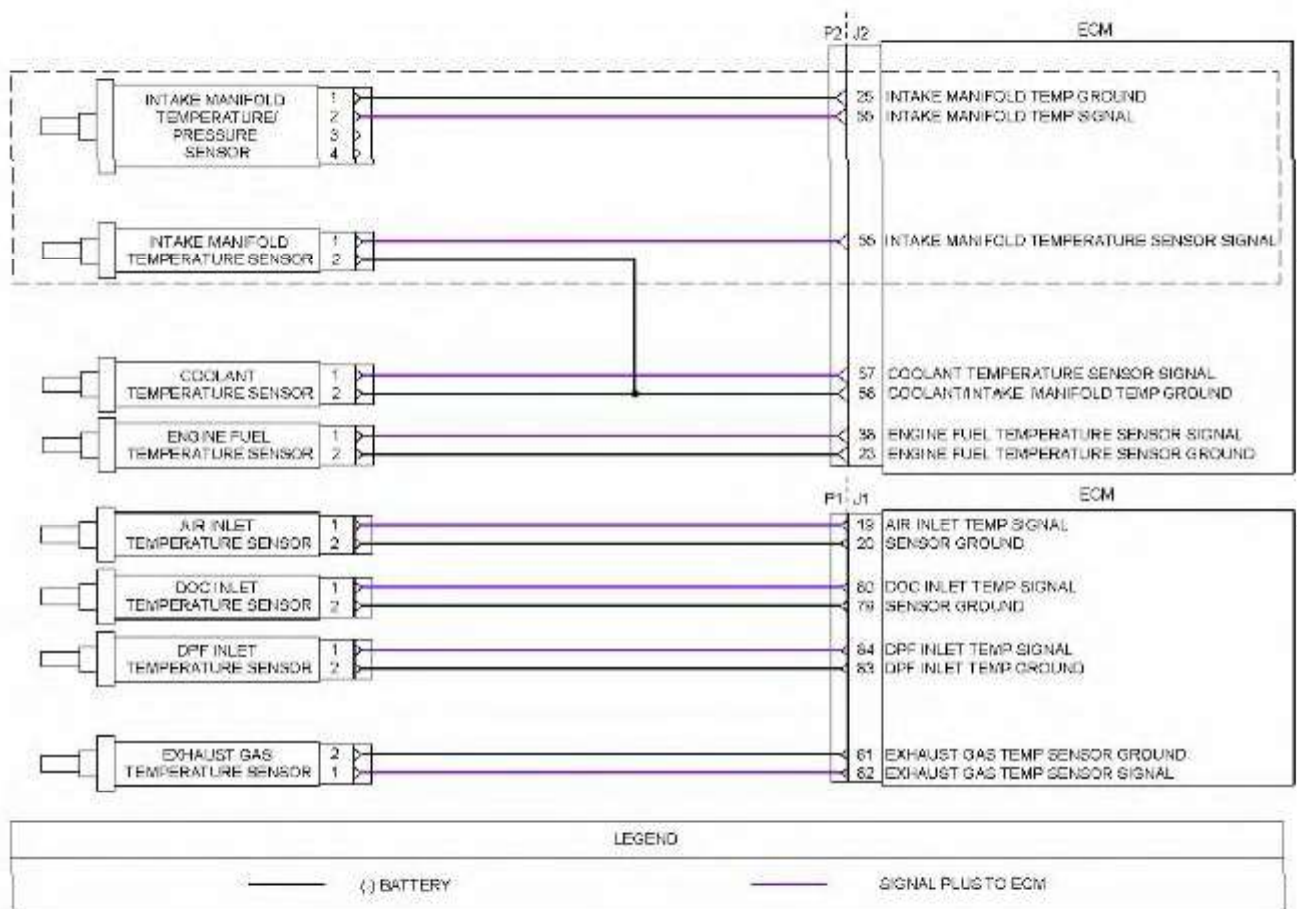

Illustration 1

g03775307

Schematic diagram for the engine temperature sensors

Not all connectors are shown. Refer to the appropriate Electrical Schematic.

Note: The engine may be equipped with a combined intake manifold pressure/temperature sensor or an individual intake manifold temperature sensor. Refer to the appropriate Electrical Schematic

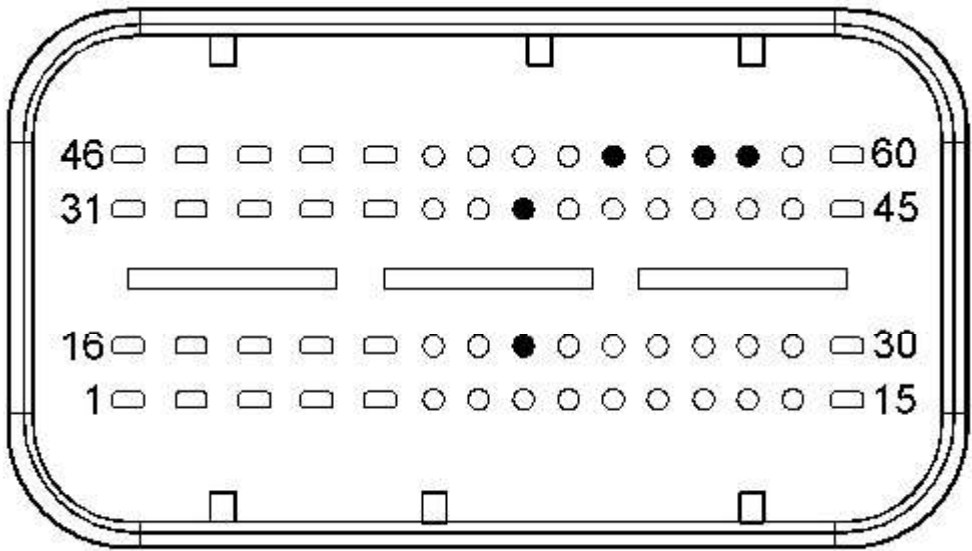

Illustration 2

g03625277

Typical view of the P2 pin locations for the temperature sensors

- (23) Engine fuel temperature sensor ground
- (38) Engine fuel temperature sensor signal
- (55) Intake manifold temperature sensor signal
- (57) Coolant temperature/intake manifold sensor signal
- (58) Intake manifold temperature sensor ground

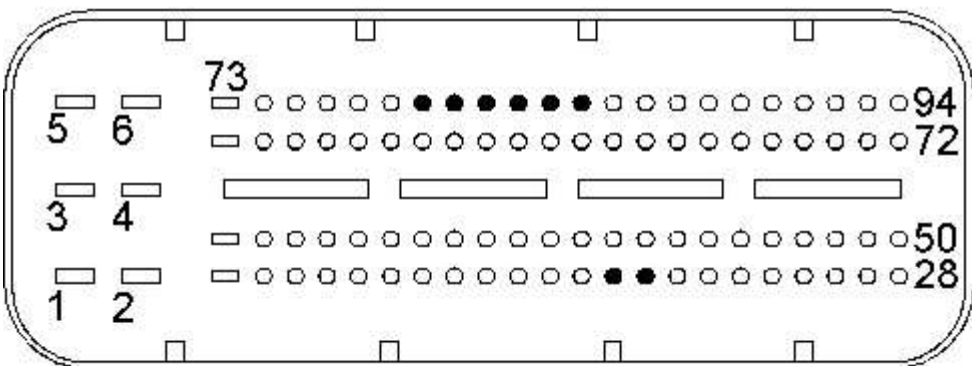

Illustration 3

g02868180

Typical view of the P1 pin locations for the temperature sensors

- (19) Air inlet temperature sensor signal
- (20) Air inlet temperature sensor ground

- (79) DOC inlet temperature sensor ground
- (80) DOC inlet temperature sensor signal
- (81) Exhaust gas temperature sensor ground
- (82) Exhaust gas temperature sensor signal
- (83) DPF inlet temperature sensor ground
- (84) DPF inlet temperature sensor signal

Table 2

Troubleshooting Test Steps	Values	Results
<p>1. Check for Diagnostic Trouble Codes</p> <p>A. Connect to the electronic service tool.</p> <p>B. Turn the keyswitch to the ON position.</p> <p>C. Access the "Active Diagnostic Code" screen on the electronic service tool.</p> <p>Wait at least 30 seconds in order for the diagnostic codes to become active.</p> <p>D. Check if any of the diagnostic codes listed in Table 1 are active or recently logged.</p>	<p>Codes</p>	<p>Result: A -3 diagnostic code is active.</p> <p>Proceed to Test Step 2.</p> <p>Result: A -4 diagnostic code is active.</p> <p>Proceed to Test Step 3.</p> <p>Result: A 3242-0 diagnostic code is active. Check that the DPF inlet and DOC inlet temperature sensors are installed in the correct location.</p> <p>Check all electrical connectors related to the DPF inlet temperature sensor circuit. Refer to Troubleshooting, "Electrical Connectors - Inspect"</p> <p>If the connectors are OK, replace the DPF inlet temperature sensor. Refer to Disassembly and Assembly, "Temperature Sensor (DPF) - Remove and Install".</p> <p>Result: If a diagnostic code is logged but not currently active, the fault may be intermittent.</p> <p>Refer to Troubleshooting, "Electrical Connectors - Inspect" in order to identify intermittent faults.</p>
<p>2. Create a Short at the Sensor Connector</p> <p>A. Turn the keyswitch to the OFF position.</p> <p>B. Disconnect the suspect sensor.</p>	<p>Short Circuit Recognized</p>	<p>Result: The -3 diagnostic code remains active for the suspect sensor.</p> <p>Repair: The fault is in the wiring for the suspect sensor. Check all wiring between the suspect sensor and the ECM. Refer to the appropriate Electrical Schematic.</p>

<p>C. Install the jumper wire between terminal 1 (sensor signal) and terminal 2 (sensor return) at the sensor connector.</p> <p>D. Turn the keyswitch to the ON position.</p> <p>E. Monitor the diagnostic codes on the electronic service tool. Check for an active -4 diagnostic code for the suspect sensor.</p> <p>Wait at least 30 seconds in order for the diagnostic codes to become active.</p> <p>F. Turn the keyswitch to the OFF position.</p>		<p>Replace the faulty wiring. Verify that the problem is resolved.</p> <p>Result: A -4 diagnostic code became active after creating the short at the sensor connector.</p> <p>Repair: The wiring is OK. Replace the suspect sensor.</p> <p>Verify that the problem is resolved.</p>
<p>3. Create an Open Circuit at the Suspect Sensor Connector</p> <p>A. Turn the keyswitch to the OFF position.</p> <p>B. Disconnect the sensor connector of the suspect sensor with the active -4 diagnostic code.</p> <p>C. Turn the keyswitch to the ON position.</p> <p>D. Monitor the diagnostic codes on the electronic service tool. Check for an active -3 diagnostic code for the suspect sensor.</p> <p>Wait at least 30 seconds in order for the diagnostic codes to become active.</p> <p>E. Turn the keyswitch to the OFF position.</p>	<p>Open Circuit Recognized</p>	<p>Result: The -4 diagnostic code remains active for the suspect sensor.</p> <p>Repair: The fault is in the wiring for the suspect sensor.</p> <p>Check all wiring between the suspect sensor and the ECM. Refer to the appropriate Electrical Schematic.</p> <p>Replace the faulty wiring. Verify that the problem is resolved.</p> <p>Result: A -3 diagnostic code became active after disconnecting the sensor.</p> <p>Repair: The wiring is OK. Replace the sensor.</p> <p>Verify that the problem is resolved.</p>
<p>If the procedure did not correct the fault, contact the Dealer Solution Network (DSN).</p>		



Previous Screen



Troubleshooting

C3.4B Engines

Media Number -UENR061.1-10

Publication Date -01/02/2015

i06019176

Sensor Supply - Test

SMCS - 1439-038

This procedure covers the following codes:

Table 1

Diagnostic trouble Codes for the Sensor Supply Circuit		
J1939 Code	Description	Notes
3509-2	Sensor Supply Voltage 1 : Erratic, Intermittent, or Incorrect	The Electronic Control Module (ECM) detects a fault in the 5 VDC sensor supply circuit supplied on the following pins: J2:8 J2:9 J2:10 J2:11 J2:12 J2:13 The engine will be derated.
3510-2	Sensor Supply Voltage 2 : Erratic, Intermittent, or Incorrect	The Electronic Control Module (ECM) detects a fault in the 5 VDC sensor supply circuit supplied on the following pins: J1:14 J1:16 If equipped, the warning lamp will come on. The engine will be derated.
3511-2		

Sensor Supply Voltage 3 : Erratic, Intermittent, or Incorrect	The Electronic Control Module (ECM) detects a fault in the 5 VDC sensor supply circuit supplied on the following pin: J1:17 If equipped, the warning lamp will come on.
--	---

The following background information is related to this procedure:

The ECM supplies regulated +5 VDC to the following sensors on the J2 connector (a 3509-2 diagnostic code applies to the 5 VDC supply for these sensors) :

- The position sensor for the intake throttle valve
- The position sensor for the NOx Reduction System (NRS) valve
- The intake manifold air pressure sensor
- The fuel rail pressure sensor
- The exhaust gas pressure sensor
- The secondary (camshaft) speed/timing sensor

The ECM supplies regulated +5 VDC to the following sensors on the J1 connector (a 3510-2 diagnostic code applies to the 5 VDC supply for these sensors) :

- The Diesel Particulate Filter (DPF) differential pressure sensor
- Analog throttle position sensor 1

The ECM supplies regulated +5 VDC to analog throttle position sensor 2 on the J1 connector. A 3511-2 diagnostic code applies to the 5 VDC supply for this sensor.

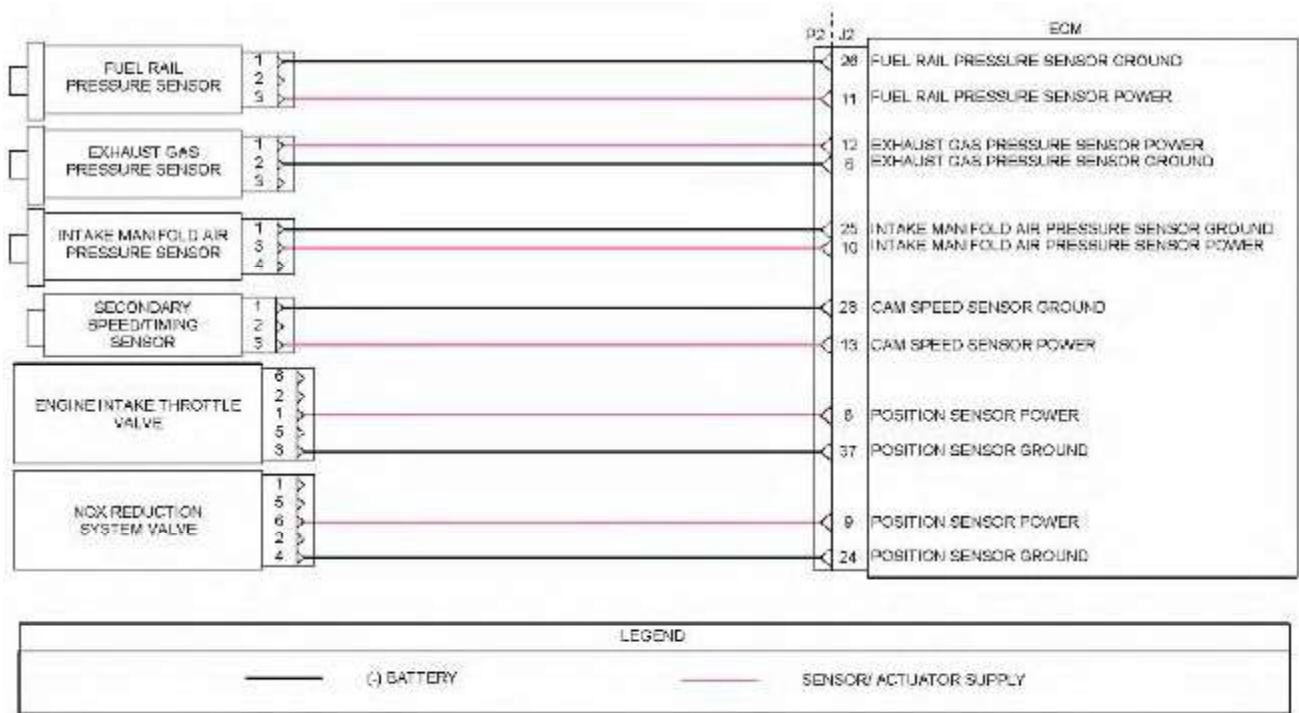

Illustration 1

g03620418

Schematic diagram of the 5 VDC supply circuit supplied by the J2 connector.
Not all connectors are shown. Refer to the appropriate Electrical Schematic.

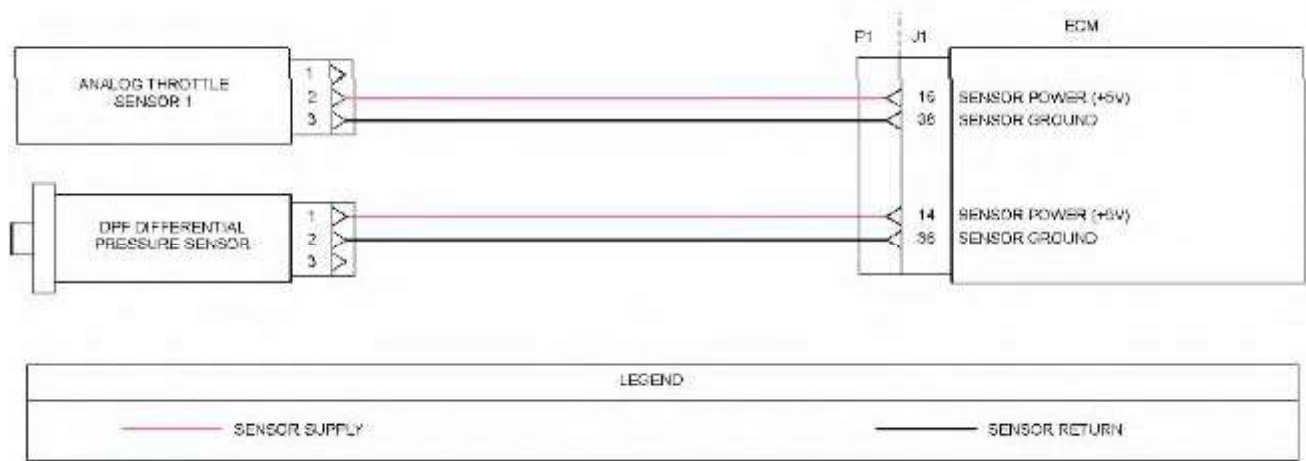

Illustration 2

g03775432

Typical example of the 5 VDC supply circuit supplied by the J1 connector. A 3510-2 diagnostic code applies to the 5 VDC supply in this illustration.

Not all connectors are shown. Refer to the Electrical Schematic for the application.

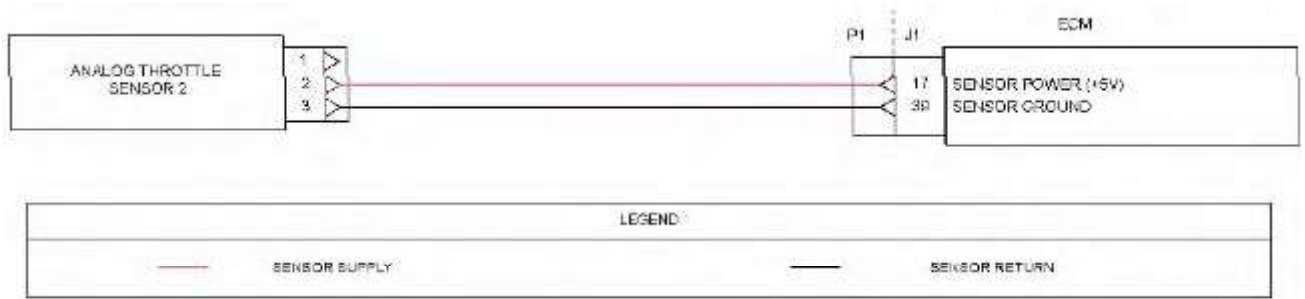

Illustration 3

g03775446

Typical example of the 5 VDC supply circuit supplied by the J1 connector. A 3511-2 diagnostic code applies to the 5 VDC supply in this illustration.

Not all connectors are shown. Refer to the Electrical Schematic for the application.

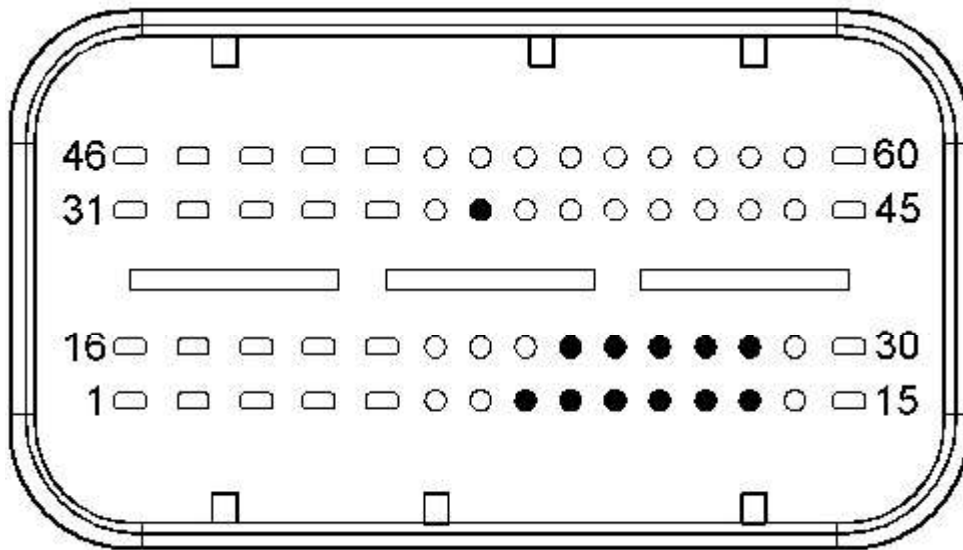

Illustration 4

g02727977

Typical view of the pin locations on the J2 connector for the 5 VDC supply.

- (8) Intake throttle valve position sensor 5 VDC supply
- (9) NRS valve position sensor 5 VDC supply
- (10) Intake manifold air pressure sensor 5 VDC supply
- (11) Fuel rail pressure sensor 5 VDC supply
- (12) Exhaust gas pressure sensor 5 VDC supply
- (13) Secondary (camshaft) speed/timing sensor 5 VDC supply
- (24) NRS valve position sensor ground
- (25) Intake manifold air pressure sensor
- (26) Fuel rail pressure sensor ground
- (27) Exhaust gas pressure sensor ground

- (28) Secondary (camshaft) speed/timing sensor ground
- (37) Intake throttle valve position sensor ground

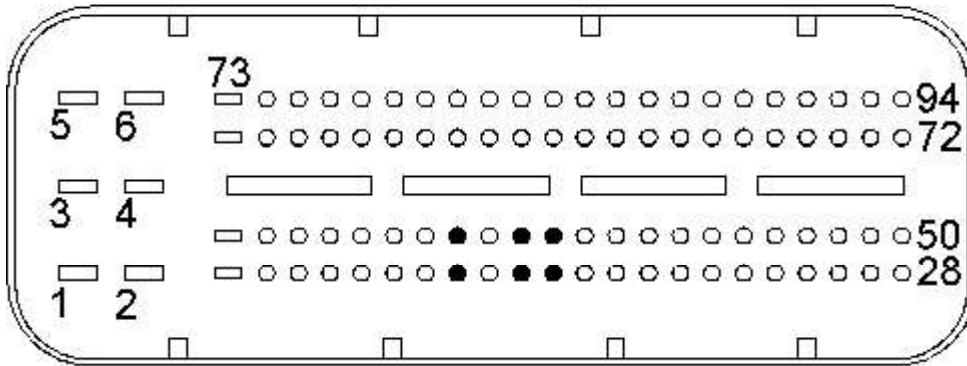

Illustration 5

g02728012

Typical view of the pin locations on the P1 connector for the 5 VDC supply

- (14) DPF differential pressure sensor 5 VDC supply
- (16) Analog throttle position sensor (1) 5 VDC supply
- (17) Analog throttle position sensor (2) 5 VDC supply
- (36) DPF differential pressure sensor ground
- (38) Analog throttle position sensor (1) ground
- (39) Analog throttle position sensor (2) ground

Table 2

Troubleshooting Test Steps	Values	Results
<p>1. Determine the Code</p> <p>A. Connect the electronic service tool to the service tool connector. Refer to Troubleshooting, "Electronic Service Tools", if necessary.</p> <p>B. Turn the keyswitch to the ON position.</p> <p>C. Check if one of the diagnostic codes listed in Table 1 is active or logged.</p>	<p>Diagnostic Codes</p>	<p>Result: A -2 diagnostic code is active.</p> <p>Note which 5 V supply is reporting the active sensor supply code.</p> <p>Proceed to Test Step 2.</p> <p>Result: A -2 diagnostic code is logged.</p> <p>An intermittent fault may be present. Refer to Troubleshooting, "Electrical Connectors - Inspect" in order to identify intermittent faults.</p>

<p>2. Check for a Failed Sensor</p> <p>A. Connect to the electronic service tool.</p> <p>B. Turn the keyswitch to the ON position.</p> <p>C. Disconnect a sensor on the suspect sensor supply circuit.</p> <p>D. Monitor the electronic service tool while the sensor is disconnected to see if the active code changes to logged.</p> <p>E. Connect the suspect sensor to the wiring harness</p> <p>F. Repeat steps C through E for each sensor on the suspect sensor supply.</p>	<p>Failed Sensor</p>	<p>Result: The suspect sensor supply active code changes to logged when a sensor is unplugged.</p> <p>Repair: Replace the failed sensor.</p> <p>Verify that the repair resolved the problem.</p> <p>Result: The suspect sensor supply active code remains active after all sensors on the sensor supply circuit have been checked.</p> <p>Repair: The fault is in the wiring harness. Check all wiring on the suspect sensor supply. Refer to the appropriate Electrical Schematic. Replace the faulty wiring.</p>
<p>If the procedure did not correct the fault, contact the Dealer Solution Network (DSN).</p>		

CAT C3.4B Engine Parts
Contact phone: 269 673 1638
Email: EngineParts@HeavyEquipmentRestorationParts.com
Alternate email: engineparts2@gmail.com
Website: www.CATC34B.com
Related website: www.HeavyEquipmentRestorationParts.com

www.FPTIndustrialEngineParts.com



Troubleshooting

C3.4B Engines

Media Number -UENR0611-10

Publication Date -01/02/2015

i05980293

Service Information Report

SMCS - 0336

After verifying that the correct repair has been performed on the engine, provide brief, detailed information. This information is crucial and helps Caterpillar better serve you and the customer.

Recommendations

Customer Complaint

Obtain as much information from the customer as possible. Investigate any written information that is available and document any information that is gathered from the customer. The following information is of particular importance:

- Indicate if an event code was logged.
- Indicate if a diagnostic code was logged. Also, record the codes that are logged.
- Indicate the symptoms of engine operation that are present.
- Indicate the engine software part number.

Be as specific as possible.

Cause of Failure

Comments on the cause of failure include the number of diagnostic codes that were logged. Comments also indicate if the code was an active code. Indicate the source of the problem. Also indicate the method that was used to discover the problem. Examples of the methods that were used to discover the problem could be one of the following methods:

- A specific procedure in the manual was followed.
- A visual inspection indicated wire abrasion on the engine harness.

- An engine dynamometer test indicated that the power was below the specification at 1700 rpm. The power loss was due to the loss of the no. 4 injector. The engine dynamometer test indicated that the power was below the specification at all engine speeds above 1700 rpm.

Be as specific as possible.

Repair Procedure

Comments on the repair procedure include the following types of information:

- The wiring harness was repaired.
- The Full Load Setting (FLS) was changed per the factory instructions.

Be as specific as possible.

[Previous Screen](#)

Troubleshooting

C3.4B Engines

Media Number -UENR061.1-10

Publication Date -01/02/2015

i06599992

Service Tool Features

SMCS - 0785; 1900

Override Parameters

The override parameters screen has multiple overrides. The parameters control various functions on the engine and the aftertreatment. These functions and features allow the technician to troubleshoot different engine systems.

Navigate to the following menu options in the electronic service tool to access the "Override Parameters":

- Diagnostics
- Diagnostic Tests
- Override Parameters

Glow Plug Starting Aid Override

This override is used to check that the glow plugs are functioning correctly. The override will remain active until switched off using the electronic service tool.

Active Diagnostic Codes

The purpose of this screen is to show all the active diagnostic codes.

In the electronic service tool, select the engine ECM.

Select the "Diagnostics" tab.

Select the "Active Diagnostic Codes" tab.

Logged Diagnostic Codes

The purpose of this screen is to show all the logged diagnostic codes. Logged diagnostic codes will be cleared from the "Logged Diagnostic Codes" screen when the code has not been active for 40 hours.

In the electronic service tool, select the engine ECM.

Select the "Diagnostics" tab.

Select the "Logged Diagnostic Codes" tab.

Diagnostic Tests

Electronic service tool diagnostic tests are listed below.

Select the "Diagnostics" tab.

Select the "Diagnostic Tests" tab.

Cylinder Cutout

This test can disable individual cylinders when the engine is running to help identify cylinders that are performing below the required level.

Click "Change" for an individual cylinder to switch off that cylinder manually. This test can be used to identify faults by listening to the sound of the engine as a cylinder is disabled. If there is no change in the sound of the engine as a cylinder is disabled, a fault in that cylinder may be indicated.

Fuel Rail Pressure Test

This test raises the fuel pressure in the high-pressure fuel rail to 180000 kPa (26107 psi) for 1 minute at 1300 rpm.

After this test has completed and the fuel pressure has dropped to a safe level, the fuel system can be inspected for signs of leakage.

Calibrations

In the electronic service tool, go to the following menu options:

Select the "Service" tab.

Select the "Calibrations" tab.

Calibrations Listed in the Engine ECM Menu

Injector Codes Calibration

Whenever an injector is replaced, the injector must be trimmed. Trimming the injector calibrates all the injectors to deliver the same amount of fuel. The Injector Codes Calibration allows the injector trim code information to be programmed into the ECM. After the injector is calibrated, the calibration data is checked for validity.

When new injectors are installed, record the serial numbers of each injector and input using the electronic service tool. Refer to Troubleshooting, "Injector Code - Calibrate" for more information.

Component Replacement Resets

In the electronic service tool, go to the "Configurations" screen.

Oxidation Catalyst Replacement Reset

Use this reset when the Diesel Oxidation Catalyst (DOC) is replaced.

Lambda Sensor Replacement Reset

Use this reset when the oxygen sensor is replaced.

EGR Valve Learn Reset

Use this reset when the Exhaust Gas Recirculation (EGR) valve is replaced.

Rail Pressure Valve Learn Reset

Use this reset when the fuel rail pressure valve is replaced. This reset will reset the counter in the ECM for the number of times that the pressure relief valve has opened.

DPF Ash Cleaning

Use this reset when the Diesel Particulate Filter (DPF) has been cleaned and reinstalled. Refer to Systems Operation, Testing and Adjusting, "Diesel Particulate Filter - Clean" for details.

Lambda Sensor Learn Reset

Use this reset when the oxygen sensor is replaced.

Lambda Sensor Temperature Learn Reset

Use this reset when the oxygen sensor is replaced.

DPF Differential Pressure Sensor Replacement

Use this reset when the DPF differential pressure sensor is replaced.

DPF Replacement Reset

Use this reset when a new DPF is installed. Refer to Systems Operation, Testing and Adjusting, "Diesel Particulate Filter - Clean" for details.



Previous Screen



Troubleshooting

C3.4B Engines

Media Number -UENR061.1-10

Publication Date -01/02/2015

i06019299

Solenoid Valve - Test

SMCS - 5479-038

This procedure covers the following codes:

Table 1

Diagnostic Trouble Codes for the Solenoid Valves		
J1939 Code	Description	Notes
1076-2	Engine Fuel Injection Pump Fuel Control Valve : Erratic, Intermittent, or Incorrect	<p>The Electronic Control Module (ECM) detects an intermittent open or short circuit error in the control circuit for the fuel metering valve on the high-pressure fuel pump.</p> <p>This diagnostic code will not be active if a continuous fault in the circuit is detected.</p>
1076-5	Engine Fuel Injection Pump Fuel Control Valve : Current Below Normal	<p>The ECM detects the following conditions:</p> <p>A low current condition in the output from the ECM to the solenoid for the fuel metering valve on the high-pressure fuel pump for at least 0.3 seconds.</p> <p>The battery voltage is at least 9.5 VDC.</p> <p>The engine will be derated.</p>
1076-6	Engine Fuel Injection Pump Fuel Control Valve : Current Above Normal	<p>The ECM detects the following conditions:</p> <p>A high current condition in the output from the ECM to the solenoid for the fuel metering valve on the high-pressure</p>

		<p>fuel pump for at least 0.2 seconds.</p> <p>The battery voltage is at least 9.5 VDC.</p> <p>The engine will be derated.</p>
1188-5	Engine Turbocharger Wastegate Actuator 1 Position : Current Below Normal	<p>The ECM detects the following conditions:</p> <p>A low current condition in the output from the ECM to the solenoid for the wastegate regulator for at least 0.2 seconds.</p> <p>The battery voltage is at least 10 VDC.</p> <p>The engine will be derated. The diagnostic code will be logged.</p>
1188-6	Engine Turbocharger Wastegate Actuator 1 Position : Current Above Normal	<p>The ECM detects the following conditions:</p> <p>A high current condition in the output from the ECM to the solenoid in the wastegate regulator for at least 0.2 seconds.</p> <p>The battery voltage is at least 10 VDC.</p> <p>The diagnostic code will be logged.</p>

The following background information is related to this procedure:

Electronically controlled wastegate

The engine has a turbocharger with an electronically controlled wastegate. Typically, the wastegate is a mechanical valve that is used in the turbocharger in order to regulate the intake manifold pressure to a set value.

The control system for the electronically controlled wastegate precisely regulates the intake manifold pressure by using a wastegate regulator to control the wastegate.

The required intake manifold pressure is calculated by the software that is contained in the ECM. The ECM uses the wastegate regulator to control the wastegate in order to provide the precise value of intake manifold pressure. The solenoid in the wastegate regulator is controlled by a PWM signal.

Fuel metering valve for the high-pressure fuel pump:

The high-pressure fuel pump is equipped with a fuel metering valve. The fuel metering valve precisely controls the amount of fuel that enters the high-pressure fuel pump.

The amount of fuel that is required is calculated by the software that is contained in the ECM. The solenoid in the suction control valve is controlled by a PWM signal from the ECM.

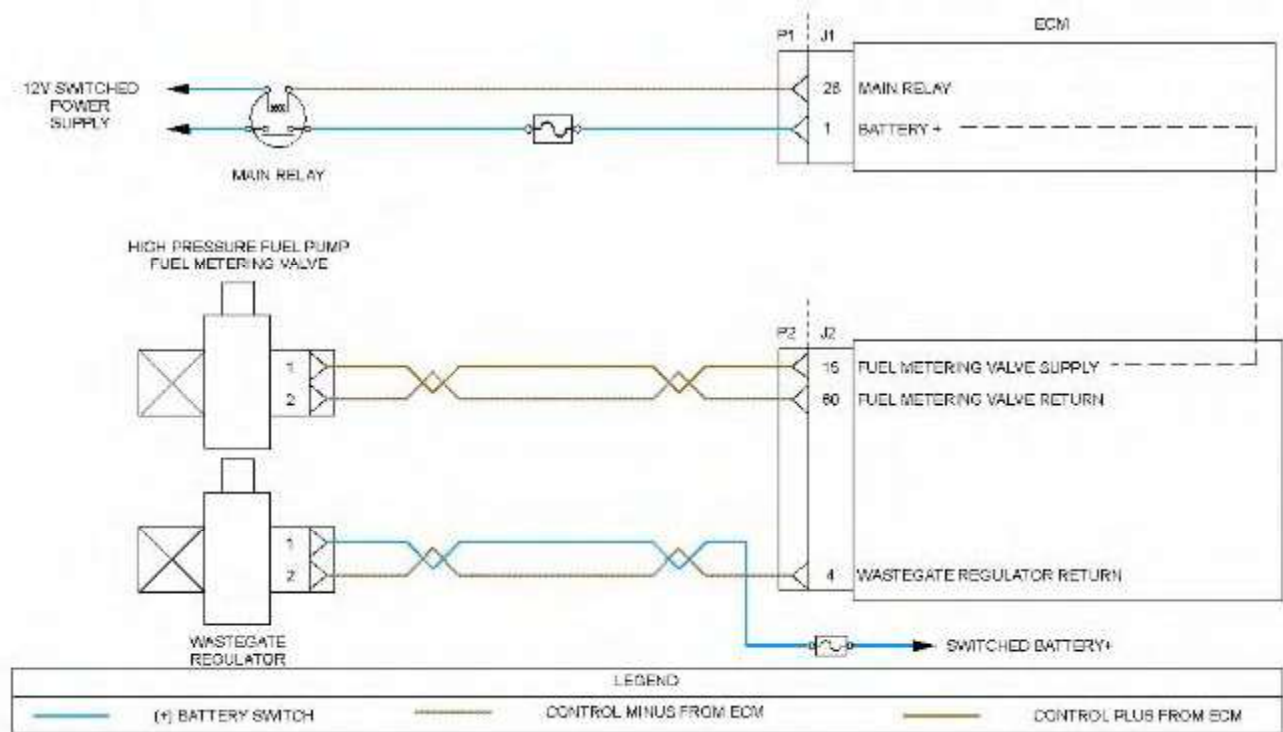

Illustration 1

g03626007

Schematic diagram for the solenoid valves

Not all connectors are shown. Refer to the appropriate Electrical Schematic.

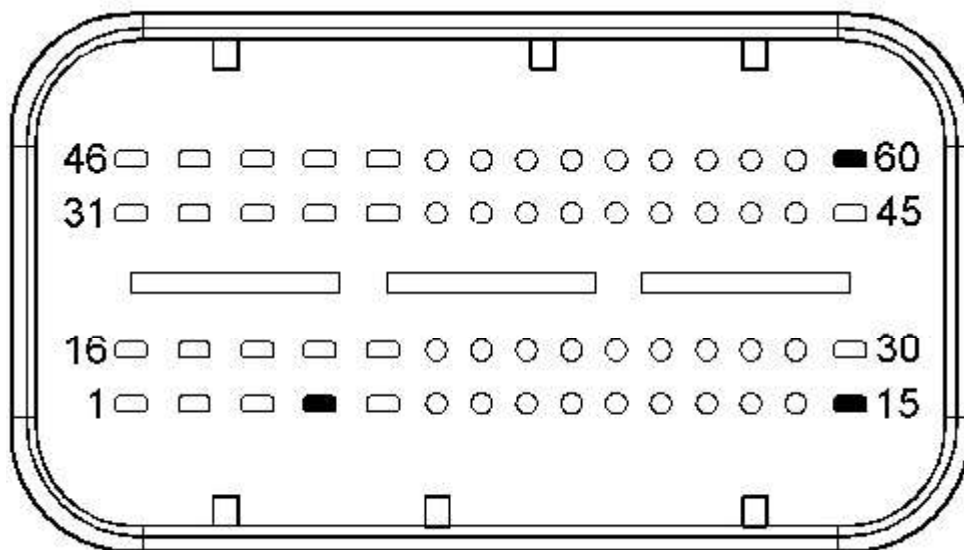

Illustration 2

g02351359

View of the pin locations on the P2 connector for the solenoid valves

(4) Wastegate regulator return

- (15) Fuel metering valve supply
- (60) Fuel metering valve return

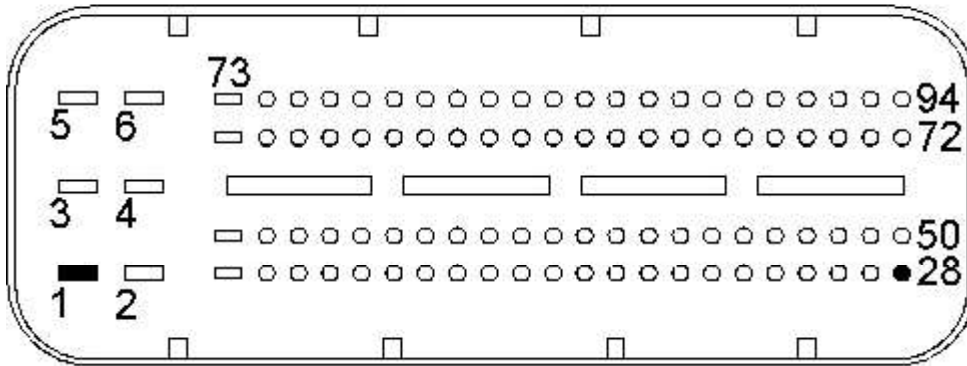

Illustration 3

g03086696

View of the pin locations on the P1 connector

Table 2

Troubleshooting Test Steps	Values	Results
<p>1. Inspect Electrical Connectors and Wiring</p> <p>A. Check the fuses.</p> <p>B. Thoroughly inspect the P2/J2 and P1/J1 ECM connectors and thoroughly inspect the connectors for the solenoid valves. Refer to Troubleshooting, "Electrical Connectors - Inspect" for details.</p> <p>C. Inspect the terminals on the P1/J1 ECM connector and all other connectors associated with the glow plug circuit.</p> <p>D. Perform a 30 N (6.7 lb) pull test on each of the wires that are associated with the solenoid valves.</p>	<p>Damaged wire or connector</p>	<p>Result: A damaged wire or damaged connector was found. A fuse is blown.</p> <p>Repair the damaged wire or the damaged connector. Replace any blown fuses Use the electronic service tool to clear all logged diagnostic codes. Verify that the repair eliminates the fault.</p> <p>Result: All connectors, pins, and sockets are correctly connected and/or inserted and the harness is free of corrosion, of abrasion or of pinch points.</p> <p>Proceed to Test Step 2.</p>

<p>2. Check for Diagnostic Codes</p> <p>A. Turn the keyswitch to the OFF position.</p> <p>B. Connect the electronic service tool to the diagnostic connector.</p> <p>C. Turn the keyswitch to the ON position.</p> <p>D. Monitor the electronic service tool for active diagnostic codes and/or logged diagnostic codes.</p>	<p>Diagnostic codes</p>	<p>Result: A 1076-5 diagnostic code is active or recently logged.</p> <p>Proceed to Test Step 3.</p> <p>Result: A 1188-5 diagnostic code is active or recently logged.</p> <p>Proceed to Test Step 4.</p> <p>Result: A 1076-6 or 1188-6 diagnostic code is active or recently logged.</p> <p>Proceed to Test Step 8.</p> <p>Result: A 1076-2 diagnostic code is active or recently logged</p> <p>An intermittent fault exists in the circuit for the fuel metering valve. For intermittent faults, refer to Troubleshooting, "Electrical Connectors - Inspect".</p>
<p>3. Check the Power Supply to the ECM</p> <p>A. Check that pin P1:1 is receiving the correct voltage. Refer to Troubleshooting, "Electrical Power Supply - Test".</p> <p>Note: The power supply for the fuel pump metering valve is supplied through P1:1.</p>	<p>Power supply</p>	<p>Result: The power supply to P1:1 is faulty.</p> <p>Perform any necessary repairs. Refer to Troubleshooting, "Electrical Power Supply - Test".</p> <p>Result: The power supply to P1:1 is OK.</p> <p>Proceed to Test Step 4.</p>
<p>4. Create a Short Circuit in the Harness at the Solenoid</p> <p>A. Turn the keyswitch to the OFF position.</p> <p>B. Disconnect the connector for the suspect solenoid.</p> <p>C. Fabricate a jumper wire that is 150 mm</p>	<p>Diagnostic codes</p>	<p>Result: An XXXX-6 diagnostic code is active when the jumper is installed.</p> <p>Temporarily connect a replacement for the suspect valve to the harness. Turn the keyswitch to the ON position. Use the electronic service tool in order to check for active diagnostic codes. Wait at least 30 seconds in order for the codes to</p>

<p>(6 inch) long.</p> <p>D. Install the wire between the two pins on the harness connector for the suspect solenoid in order to create a short circuit.</p> <p>E. Turn the keyswitch to the ON position. Check for active diagnostic codes on the electronic service tool.</p> <p>F. Remove the jumper wire from the connector for the solenoid valve.</p>		<p>be displayed.</p> <p>If the fault is eliminated, reconnect the suspect valve. If the fault returns, permanently install the replacement valve. Refer to Disassembly and Assembly for the correct procedure.</p> <p>Result: A 1076-5 diagnostic code is still active with the jumper installed.</p> <p>Proceed to Test Step 5.</p> <p>Result: A 1188-5 diagnostic code is still active with the jumper installed.</p> <p>Proceed to Test Step 6.</p>
<p>5. Create a Short Circuit at the ECM Connector</p> <p>A. Turn the keyswitch to the OFF position.</p> <p>B. Disconnect the P2 connector from the ECM.</p> <p>C. Fabricate a jumper wire and install the jumper wire between J2:15 and J2:60.</p> <p>D. Turn the keyswitch to the ON position.</p> <p>E. Use the electronic service tool to check for an active 1076 diagnostic code. Wait at least 30 seconds for activation of the diagnostic codes.</p> <p>F. Turn the keyswitch to the OFF position.</p> <p>G. Remove the jumper wire.</p> <p>H. Reconnect the connectors.</p>	<p>Diagnostic codes</p>	<p>Result: A 1076-6 diagnostic code is active with the jumper installed.</p> <p>The fault is in the harness between the fuel pump metering valve connector and the P2 ECM connector.</p> <p>Replace the faulty wiring. Use the electronic service tool to clear all logged diagnostic codes and verify that the repair eliminates the fault.</p> <p>Result: The 1076-5 diagnostic code is still active with the jumper installed.</p> <p>Proceed to Test Step 10.</p>
<p>6. Measure the Voltage at the Wastegate Regulator Connector</p> <p>A. Turn the keyswitch to the OFF position.</p>	<p>10 V to 14 V</p>	<p>Result: The measured voltage is not within the expected range.</p> <p>Check the fuse. If the fuse is blown, there is a short circuit in the switched battery</p>

<p>B. Disconnect the wastegate regulator.</p> <p>C. Turn the keyswitch to the ON position.</p> <p>D. Use a multimeter to measure the voltage between terminal 1 on the harness connector for the wastegate regulator and a suitable ground.</p>		<p>supply to the wastegate regulator connector.</p> <p>If the fuse is not blown, there is an open circuit in the switched battery supply to the wastegate regulator connector.</p> <p>Repair the faulty wiring or replace the faulty wiring. Use the electronic service tool to clear all logged diagnostic codes and verify that the repair eliminates the fault.</p> <p>Result: The measured voltage is within the expected range.</p> <p>Proceed to Test Step 8.</p>
<p>7. Check the Wastegate Regulator Return Wire for an Open Circuit</p> <p>A. Turn the keyswitch to the OFF position.</p> <p>B. Disconnect the wastegate regulator and the P2 connector.</p> <p>C. Use a suitable multimeter to measure the resistance between P2:4 and terminal 2 on the harness connector for the wastegate regulator.</p>	<p>Diagnostic codes</p>	<p>Result: The measured resistance is greater than 5 Ohms.</p> <p>The fault is in the wiring between the wastegate regulator and the P2 ECM connector.</p> <p>Replace the faulty wiring. Use the electronic service tool to clear all logged diagnostic codes and verify that the repair eliminates the fault.</p> <p>Result: The measured resistance is less than 5 Ohms.</p> <p>Proceed to Test Step 10.</p>
<p>8. Create an Open Circuit at the Solenoid</p> <p>A. Turn the keyswitch to the OFF position.</p> <p>B. Disconnect the connector for the suspect solenoid valve.</p> <p>C. Turn the keyswitch to the ON position. Check for active diagnostic codes on the electronic service tool. Wait at least 30 seconds for activation of the diagnostic codes.</p>	<p>Diagnostic codes</p>	<p>Result: An XXXX-5 diagnostic code is active with the valve disconnected.</p> <p>Temporarily connect a replacement for the suspect valve to the harness.</p> <p>Turn the keyswitch to the ON position. Use the electronic service tool in order to check for active diagnostic codes. Wait at least 30 seconds in order for the codes to be displayed.</p> <p>If the fault is eliminated, reconnect the suspect valve. If the fault returns, permanently install the replacement valve. Refer to Disassembly and Assembly for</p>

<p>D. Turn the keyswitch to the OFF position.</p>		<p>the correct procedure.</p> <p>Result: An XXXX-6 diagnostic code is still active with the valve disconnected.</p> <p>Proceed to Test Step 9.</p>
<p>9. Create an Open Circuit at the ECM</p> <p>A. Turn the keyswitch to the OFF position.</p> <p>B. Disconnect the P2 connector from the ECM.</p> <p>C. Turn the keyswitch to the ON position. Wait at least 30 seconds for activation of the diagnostic codes.</p> <p>D. Use the electronic service tool to check for active diagnostic codes.</p> <p>Note: Diagnostic codes for all of the engine sensors will be active with the P2 connector disconnected. Ignore all other codes and only look for codes that relate to the suspect valve.</p> <p>E. Turn the keyswitch to the OFF position.</p>	<p>Diagnostic codes</p>	<p>Result: An XXXX-5 diagnostic code is active with the P2 connector disconnected.</p> <p>The fault is in the wiring between the suspect valve connector and the P2 ECM connector.</p> <p>Replace the faulty wiring. Use the electronic service tool to clear all logged diagnostic codes and verify that the repair eliminates the fault.</p> <p>Result: The XXXX-6 diagnostic code is still active with the P2 connector disconnected.</p> <p>Proceed to Test Step 10.</p>
<p>10. Check if a Replacement ECM Eliminates the Fault</p> <p>A. Contact the Dealer Solution Network (DSN).</p> <p>B. If the DSN recommends the use of a replacement ECM, install a replacement ECM. Refer to Troubleshooting, "Replacing the ECM".</p> <p>C. Use the electronic service tool to recheck the system for active diagnostic codes.</p>	<p>Diagnostic codes</p>	<p>Result: There are no active diagnostic codes with the replacement ECM.</p> <p>Reconnect the suspect ECM. If the fault returns with the suspect ECM, replace the ECM.</p> <p>Use the electronic service tool in order to clear all logged diagnostic codes and then verify that the repair eliminates the fault.</p> <p>Result: The diagnostic code is still present with the replacement ECM.</p> <p>Contact the DSN.</p>



Previous Screen



Troubleshooting

C3.4B Engines

Media Number -UENR0611-10

Publication Date -01/02/2015

i06231642

Speed Control - Test

SMCS - 7332-038-VF

This procedure covers the following codes:

Table 1

Diagnostic Trouble Codes for the Analog Throttle Position Sensors		
J1939 Code	Description	Notes
91-3	Accelerator Pedal Position 1 : Voltage Above Normal	The Electronic Control Module (ECM) detects that the signal from the throttle position sensor is greater than the upper diagnostic limit for at least 0.2 seconds. The warning lamp will flash. The engine will be derated.
29-3	Accelerator Pedal Position 2: Voltage Above Normal	
91-4	Accelerator Pedal Position 1 : Voltage Below Normal	The ECM detects that the signal from the throttle position sensor is less than the lower diagnostic limit for at least 0.2 seconds. The warning lamp will flash. The engine will be derated.
29-4	Accelerator Pedal Position 2: Voltage Below Normal	

If a fault occurs with the primary throttle and a secondary throttle is installed, the engine will use the secondary throttle until the fault is repaired.

If a fault occurs with the secondary throttle, the engine will use the primary throttle until the fault is repaired.

If a functional throttle is not available, the following conditions will occur:

- The engine will default to the limp home speed.

- If the engine speed is higher than the limp home speed, the engine will decelerate to the limp home speed.
- If the engine speed is lower than the limp home speed, the engine speed will remain at the current speed.
- The engine will remain at this speed while the diagnostic code remains active.
- All inputs from the faulty throttle are ignored by the ECM until the fault is repaired.
- All inputs from the repaired throttle will be ignored by the ECM until the keyswitch has been cycled.

The diagnostic codes above relate to an analog sensor. Use this procedure only if the analog sensor uses an output from a variable resistor.

The sensor is most likely to be mounted on a throttle pedal. The sensor is attached directly to the throttle assembly. The sensor provides an output voltage to the ECM. The sensor output voltage will vary with the position of the throttle. Foot operated or hand operated throttle assemblies are available.

The sensor receives +5 V power from the ECM. The sensor will produce a raw signal voltage that will alter between low idle and high idle.

The sensor senses the speed requirement from the throttle position. A second sensor may override this speed requirement from the first sensor. This override will be subject to an input from a secondary throttle or from the SAE J1939 (CAN) data link or from a PTO control.

Use the electronic service tool in order to check the input status.

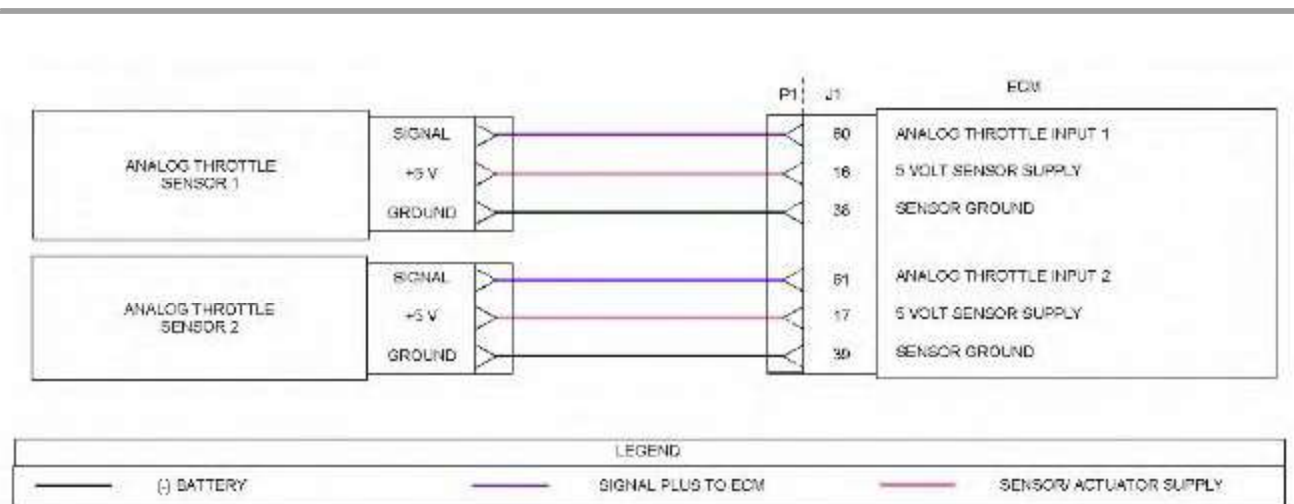

Illustration 1

g03733275

Schematic diagram for the throttle position sensors

Not all connectors are shown. Refer to the Electrical Schematic for the application.

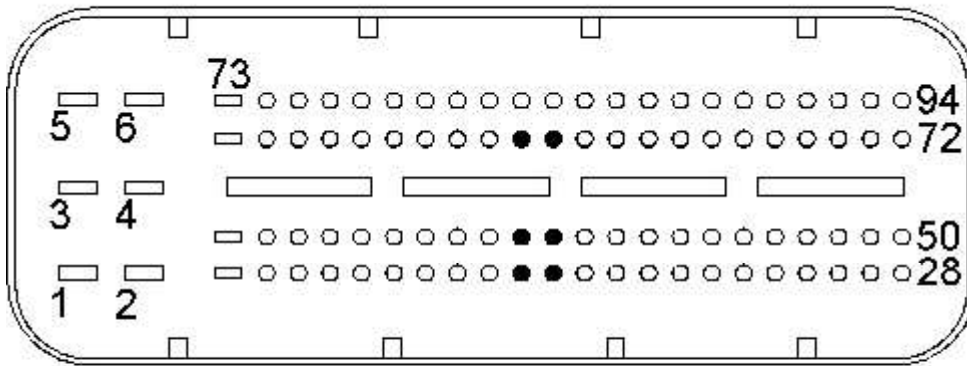

Illustration 2

g02292314

View of the P1 pin locations for the analog throttle position sensors

- (16) 5 V supply (throttle 1)
- (17) 5 V supply (throttle 2)
- (38) Throttle 1 ground
- (39) Throttle 2 ground
- (60) Throttle 1 position
- (61) Throttle 2 position

Table 2

Troubleshooting Test Steps	Values	Results
<p>1. Inspect Electrical Connectors and Wiring</p> <p>A. Turn the keyswitch to the OFF position.</p> <p>B. Check the connectors and the harness for the following faults:</p> <ul style="list-style-type: none"> · Abrasion · Corrosion · Incorrect attachment <p>Refer to Troubleshooting, "Electrical Connectors - Inspect".</p> <p>C. Perform a 30 N (6.7 lb) pull test on each of the wires in the harness that are associated with the throttle position sensor. Check the wire connectors at the ECM and at the throttle sensor.</p>	<p>Damaged wire or connector</p>	<p>Result: A damaged wire or damaged connector was found.</p> <p>Repair: Repair the damaged wire or the damaged connector. Replace any blown fuses</p> <p>Use the electronic service tool to clear all logged diagnostic codes. Verify that the repair eliminates the fault.</p> <p>Result: All connectors, pins, and sockets are correctly connected and/or inserted and the harness is free of corrosion, of abrasion or of pinch points.</p> <p>Proceed to Test Step 2.</p>

<p>D. Check the harness for abrasions and for pinch points from the sensors back to the ECM.</p>		
<p>2. Check For Active Diagnostic Codes</p> <p>A. Turn the keyswitch to the ON position.</p> <p>B. Use the electronic service tool to check for diagnostic codes.</p>	<p>Diagnostic codes</p>	<p>Result: One or more of the diagnostic codes that are listed in Table 1 is active or recently logged.</p> <p>Proceed to Test Step 5.</p> <p>Result: There are no active or recently logged diagnostic codes for the analog throttle position sensors.</p> <p>Proceed to Test Step 3.</p>
<p>3. Check the Throttle Position with the Electronic Service Tool</p> <p>A. Connect the electronic service tool to the diagnostic connector.</p> <p>B. Turn the keyswitch to the ON position. Do not start the engine.</p> <p>C. Observe the throttle position reading on the throttle status screens in the electronic service tool.</p> <p>D. Operate the throttle over the full range of movement.</p>	<p>0 percent at low idle</p> <p>100 percent at high idle</p>	<p>Result: The throttle output is 0 percent at low idle and 100 percent at high idle.</p> <p>Proceed to Test Step 4.</p> <p>Result: The throttle output is not correct.</p> <p>Repair: Use the electronic service tool to verify that the throttle has been configured correctly before continuing with this procedure. For information on the parameters that can be configured, refer to Troubleshooting, "Configuration Parameters".</p> <p>If the fault is still present after the throttle has been configured correctly, replace the analog throttle position sensor.</p>
<p>4. Check the Throttle Selection Status with the Electronic Service Tool</p> <p>A. Check the status of the throttle selection switch (if equipped). Use the electronic service tool in order to check the status of the throttle selection switch.</p> <p>Note: The control of the engine speed may</p>	<p>Switch status</p>	<p>Result: If the status of the throttle selection switch is shown in the OFF position, then the throttle 1 has control of the engine speed. If the throttle selection switch status is shown in the ON position, then the throttle 2 has control of the engine speed.</p> <p>The throttle selection switch is operating correctly.</p>

<p>not switch between throttles unless both throttles are in the low idle position. The throttle may be overridden by using the SAE J1939 (CAN) data link or a PTO control.</p>		<p>Repair: There may be an intermittent fault. Refer to Troubleshooting, "Electrical Connectors - Inspect" in order to identify intermittent faults.</p> <p>Result: The incorrect throttle is selected.</p> <p>Repair: Change to the other throttle. There may be a fault with the selector switch input. Check the connections between the throttle selection switch and P1:62 and battery -. Refer to Troubleshooting, "Electrical Connectors - Inspect". Refer to the Electrical Schematic for the application.</p>
<p>5. Check the Voltage at the Sensor</p> <p>A. Turn the keyswitch to the OFF position.</p> <p>B. Disconnect the connector for the suspect throttle position sensor.</p> <p>C. Turn the keyswitch to the ON position.</p> <p>D. Measure the voltage between the 5 V terminal and the sensor ground terminal on the harness connector for the sensor.</p>	<p>4.9 V to 5.1 V</p>	<p>Result: The measured voltage is not within the expected range. The fault is in the 5 V supply wire or the ground wire between the throttle position sensor and the ECM.</p> <p>Repair: Check all wiring between the suspect sensor and the ECM. Refer to the Electrical Schematic for the application. Replace the faulty wiring. Use the electronic service tool to clear all logged diagnostic codes and verify that the repair eliminates the fault.</p> <p>Result: The measured voltage is within the expected range.</p> <p>Proceed to Test Step 8.</p>
<p>6. Verify the Type of Active Diagnostic Code</p> <p>A. Turn the keyswitch to the ON position. Wait at least 10 seconds for activation of the diagnostic codes.</p> <p>B. Use the electronic service tool to check for active diagnostic codes. Record all active diagnostic codes.</p>	<p>Diagnostic codes</p>	<p>Result: A -3 diagnostic code is active at this time.</p> <p>Proceed to Test Step 7.</p> <p>Result: A -4 diagnostic code is active at this time.</p> <p>Proceed to Test Step 9.</p> <p>Result: There are no active diagnostic codes for the throttle position sensors.</p>

		<p>Repair: The fault may be intermittent. Refer to Troubleshooting, "Electrical Connectors - Inspect".</p>
<p>7. Create an Open Circuit at the Sensor Connector</p> <p>A. Turn the keyswitch to the OFF position.</p> <p>B. Disconnect the throttle position sensor with the -3 diagnostic code.</p> <p>C. Turn the keyswitch to the ON position. Wait for at least 10 seconds for activation of the diagnostic codes.</p> <p>D. Use the electronic service tool to check the "Active Diagnostic Code" screen. Check for an -4 diagnostic code.</p> <p>E. Turn the keyswitch to the OFF position.</p>	<p>Diagnostic Codes</p>	<p>Result: A -4 diagnostic code became active after disconnecting the sensor.</p> <p>Install a replacement sensor. Use the electronic service tool to clear all logged diagnostic codes and verify that the repair eliminates the fault.</p> <p>Result: There is still an active -3 diagnostic code with the sensor disconnected.</p> <p>Proceed to Test Step 8.</p>
<p>8. Check for a Short Circuit in the Wiring for the Sensor</p> <p>A. Turn the keyswitch to the OFF position.</p> <p>B. Disconnect the suspect throttle position sensor. Disconnect the P1 connector from the ECM.</p> <p>C. Use a suitable multimeter to measure the resistance between the sensor signal terminal on the P1 connector and all other terminals on the P1 connector.</p>	<p>Greater than 1 k Ohm</p>	<p>Result: At least one of the resistance measurements is greater than 1 k Ohm. There is a short in the wiring for the sensor.</p> <p>Repair: Check all wiring between the suspect sensor and the ECM. Refer to the Electrical Schematic for the application. Replace the faulty wiring. Use the electronic service tool to clear all logged diagnostic codes and verify that the repair eliminates the fault.</p> <p>Result: All resistance measurements are greater than 1 k Ohm.</p> <p>Contact the Dealer Solution Network (DSN).</p>
<p>9. Create a Short Circuit at the Sensor Connector</p> <p>A. Turn the keyswitch to the OFF position.</p>	<p>Diagnostic codes</p>	<p>Result: A -3 diagnostic code is active when the jumper is installed.</p> <p>Install a replacement sensor.</p>

<p>B. Disconnect the connector for the throttle position sensor with the XX-4 diagnostic code.</p> <p>C. Fabricate a jumper wire that is 150 mm (6 inch) long.</p> <p>D. Insert one end of the jumper wire into the terminal for the 5 V supply on the harness connector for the suspect sensor. Insert the other end of the jumper wire into the signal terminal on the harness connector for the suspect sensor.</p> <p>E. Turn the keyswitch to the ON position</p> <p>F. Access the "Active Diagnostic Codes" screen on the electronic service tool and check for an active -3 diagnostic code for the suspect sensor.</p> <p>G. Remove the jumper.</p>		<p>Use the electronic service tool to clear all logged diagnostic codes and verify that the repair eliminates the fault.</p> <p>Result: A -4 diagnostic code remains active when the jumper is installed.</p> <p>Proceed to Test Step 10.</p>
<p>10. Check the Sensor Signal Wire for an Open Circuit</p> <p>A. Turn the keyswitch to the OFF position.</p> <p>B. Disconnect the suspect throttle position sensor connector. Disconnect the P1 connector from the ECM.</p> <p>C. Use a suitable multimeter to measure the resistance between the sensor signal terminal on the harness connector for the sensor and the sensor signal terminal on the P1 connector.</p>	<p>Less than 5 Ohms</p>	<p>Result: The measured resistance is greater than 5 Ohms. There is an open circuit or high resistance in the sensor signal wire between the sensor connector and the P1 connector.</p> <p>Repair: Check all wiring between the suspect sensor and the ECM. Refer to the Electrical Schematic for the application. Replace the faulty wiring. Use the electronic service tool in order to clear all logged diagnostic codes and then verify that the repair eliminates the fault.</p> <p>Result: The measured resistance is less than 5 Ohms.</p> <p>Contact the DSN.</p>
<p>If the procedure did not correct the fault, contact the DSN.</p>		



Previous Screen



Troubleshooting

C3.4B Engines

Media Number -UENR061.1-10

Publication Date -01/02/2015

i06019830

Speed/Timing - Test

SMCS - 1912-038

This procedure covers the following codes:

Table 1

Diagnostic Trouble Codes for the Engine Speed/Timing Sensors		
J1939 Code	Description	Notes
190-8	Engine Speed : Abnormal Frequency, Pulse Width, or Period	<p>The Electronic Control Module (ECM) detects the following conditions:</p> <p>A loss of signal from the primary speed/timing sensor for four camshaft revolutions.</p> <p>OR</p> <p>An invalid signal from the primary speed/timing sensor.</p> <p>The engine speed is at least 450 rpm.</p> <p>There is a valid signal from the secondary speed/timing sensor.</p> <p>The diagnostic code will be logged.</p> <p>The ECM will use the signal from the secondary speed/timing sensor.</p> <p>The engine will be derated. If the signal from the secondary speed/timing sensor is also lost, the engine will shut down.</p>
723-8		<p>The Electronic Control Module (ECM) detects the following conditions:</p>

	<p>Engine Speed Sensor #2 : Abnormal Frequency, Pulse Width or Period</p>	<p>A loss of signal from the secondary speed/timing sensor for four crankshaft revolutions. OR An invalid signal from the secondary speed/timing sensor for one engine revolution.</p> <p>The engine is running.</p> <p>The diagnostic code will be logged. The loss of signal from the secondary speed/timing sensor will prevent the engine from starting.</p>
637-11	<p>Engine Timing Sensor : Other Failure Mode</p>	<p>The Electronic Control Module (ECM) detects the following conditions:</p> <p>The outputs from the primary speed/timing sensor and the secondary speed/timing sensor differ by more than 10 crankshaft degrees for at least four engine revolutions.</p> <p>The engine is running.</p> <p>There is a valid signal from the secondary speed/timing sensor.</p>

The engine uses two engine speed/timing sensors. The primary speed/timing sensor is located on the front left-hand side of the cylinder block. The primary speed/timing sensor generates a signal by detecting the movement of the teeth that are located on the crankshaft timing ring. The signal that is generated by the speed/timing sensor is transmitted to the ECM. The ECM uses the signal from the speed/timing sensor to calculate the position of the crankshaft. The signal is also used to determine the engine speed.

The secondary speed/timing sensor is located in the front cover. The secondary speed/timing sensor generates a signal that is related to the camshaft position. The secondary speed/timing sensor detects the movement of the position wheel on the front of the camshaft. The signal that is generated by the speed/timing sensor is transmitted to the ECM. The ECM calculates the speed and the rotational position of the engine by using the signal. The secondary speed/timing sensor is required for starting purposes.

During normal operation, the secondary speed/timing sensor is used to determine the cycle that the engine is on. When the timing has been established, the primary speed/timing sensor is then used to determine the engine speed and the angular position.

The loss of signal to the primary sensor and/or the secondary sensor will result in one of the following faults:

- The engine will continue to run when only one sensor signal is present from either the primary sensor or the secondary sensor.
- Loss of signal from the primary sensor and the secondary sensor during operation of the engine will cause fuel injection to be terminated and the engine will stop.

Pull-up Voltage

The ECM continuously outputs a pull-up voltage on the circuit for the secondary speed/timing sensor signal wire. This pull-up voltage is required for correct sensor operation and diagnostics.

When the sensor is disconnected, this pull-up voltage can be measured at the harness connector for the sensor.

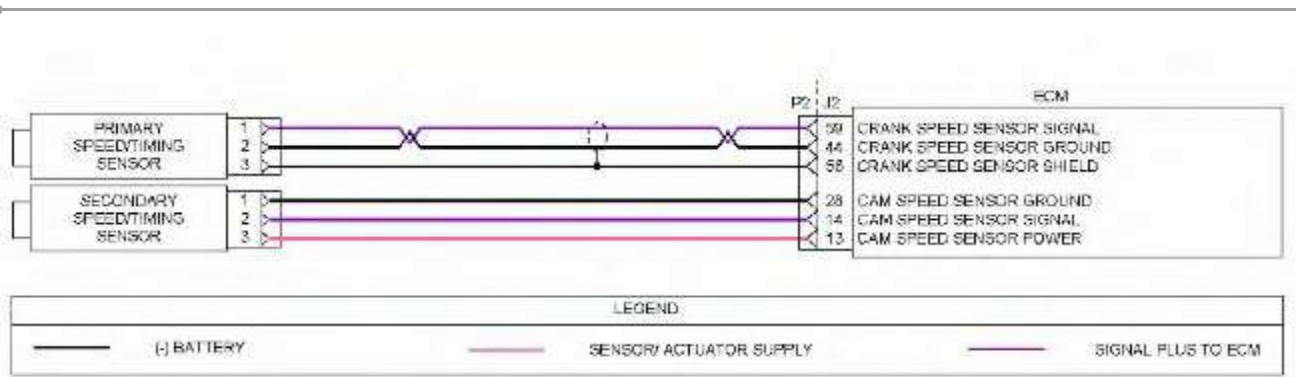

Illustration 1

g03628020

Schematic diagram for the engine speed/timing sensors

Not all connectors are shown. Refer to the appropriate Electrical Schematic.

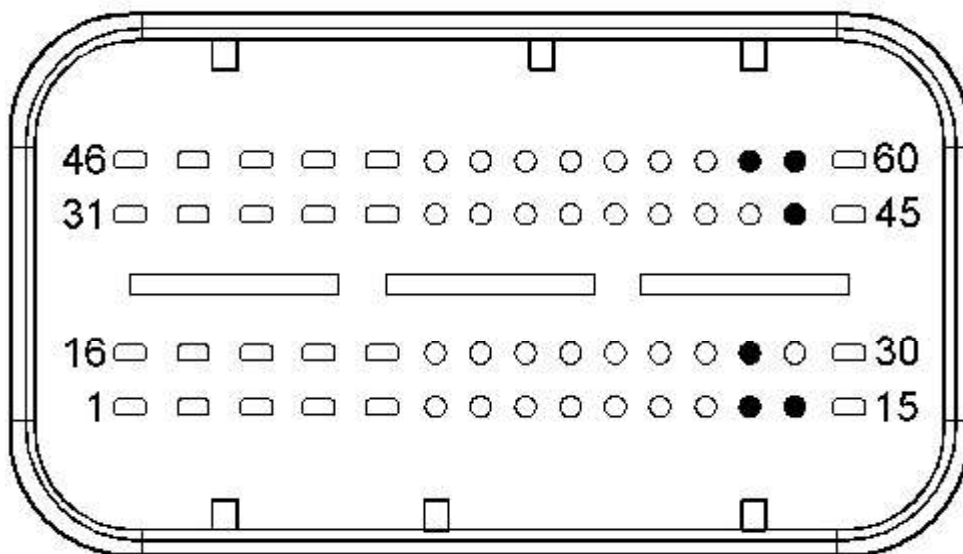

Illustration 2

g02648462

View of the pin locations for the speed/timing sensors on the P2 connector

- (13) Secondary speed/timing sensor 5 V supply
- (14) Secondary speed/timing sensor signal
- (28) Secondary speed/timing sensor ground
- (44) Primary speed/timing sensor return

(58) Shield

(59) Primary speed/timing sensor supply

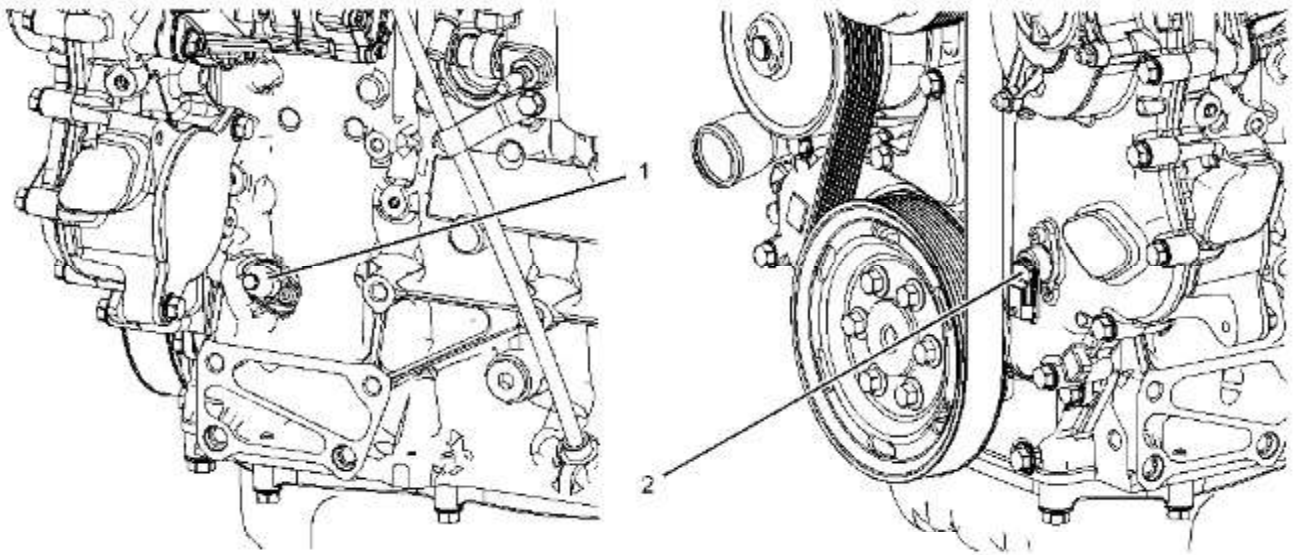

Illustration 3

g02648476

View of the sensor locations

(1) Primary speed/timing sensor

(2) Secondary speed/timing sensor

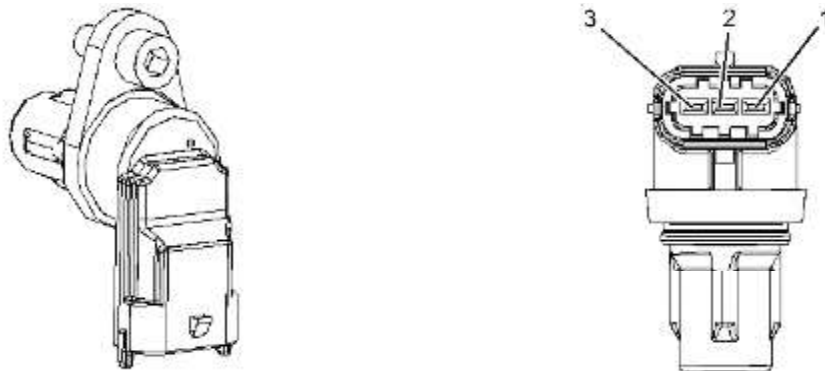

Illustration 4

g02648517

Typical example of the secondary speed/timing sensor

(1) Secondary speed/timing sensor ground

(2) Secondary speed/timing sensor signal

(3) Secondary speed timing sensor 5 V supply

Table 2

Troubleshooting Test Steps	Values	Results
1. Inspect Electrical Connectors and Wiring	Damaged	Result: A damaged wire or

<p>A. Turn the keyswitch to the OFF position.</p> <p>B. Inspect the connectors for the speed/timing sensors. Refer to Troubleshooting, "Electrical Connectors - Inspect".</p> <p>C. Perform a 30 N (6.7 lb) pull test on each of the wires in the suspect sensor connector and the sensor connections at the ECM.</p> <p>D. Check that the ground connection on the ECM and the negative terminal on the battery are correctly installed.</p> <p>E. Check the ground connection on the ECM for abrasions and pinch points.</p> <p>F. Check the harness for abrasion and pinch points from the suspect sensor to the ECM.</p> <p>G. Check that the suspect sensor is installed correctly. Check that the suspect sensor is fully seated into the engine. Check that the sensor is securely latched.</p>	<p>wire or connector</p>	<p>damaged connector was found.</p> <p>Repair the damaged wire or the damaged connector. Use the electronic service tool to clear all logged diagnostic codes. Verify that the repair eliminates the fault.</p> <p>Result: All connectors, pins, and sockets are correctly connected and/or inserted and the harness is free of corrosion, of abrasion or of pinch points.</p> <p>Proceed to Test Step 2.</p>
<p>2. Check for Active Diagnostic Codes and Recently Logged Diagnostic Codes</p> <p>A. Turn the keyswitch to the OFF position.</p> <p>B. Connect the electronic service tool to the diagnostic connector.</p> <p>C. Turn the keyswitch to the ON position. If the engine will start, then run the engine.</p> <p>D. Use the electronic service tool in order to monitor active diagnostic codes or recently logged diagnostic codes.</p>	<p>Diagnostic codes</p>	<p>Result: Diagnostic code 190-8 is active or recently logged.</p> <p>Proceed to Test Step 3.</p> <p>Result: Diagnostic code 723-8 is active or recently logged.</p> <p>Proceed to Test Step 5.</p> <p>Result: Diagnostic code 637-11 is active or recently logged.</p> <p>Proceed to Test Step 8.</p>
<p>3. Measure the Signal Frequency at the Sensor Connector</p> <p>A. Turn the keyswitch to the OFF position.</p> <p>B. Disconnect the primary speed/timing sensor.</p>	<p>At least 100 Hz.</p>	<p>Result: The measured frequency is less than 100 Hz.</p> <p>Remove the primary speed/timing sensor. Refer to Disassembly and Assembly,</p>

<p>Note: A multimeter that can measure frequency (Hz) is required for this procedure.</p> <p>C. Connect the multimeter to pin 1 and pin 2 on the sensor connector.</p> <p>D. Turn the keyswitch to the START position.</p> <p>E. Record the frequency while the engine is cranking.</p>		<p>"Crankshaft Position Sensor - Remove and Install".</p> <p>Inspect the primary speed/timing sensor for damage and/or debris. If the primary speed/timing sensor is free from damage and/or debris, install a new primary speed/timing sensor. Refer to Disassembly and Assembly, "Crankshaft Position Sensor - Remove and Install". Use the electronic service tool in order to clear all logged diagnostic codes and then verify that the repair eliminates the fault.</p> <p>If the primary speed/timing sensor is damaged and/or contaminated with debris, proceed to Test Step 9.</p> <p>Result: The measured frequency is greater than 100 Hz.</p> <p>Proceed to Test Step 4.</p>
<p>4. Check the Engine Wiring Harness</p> <p>A. Turn the keyswitch to the OFF position.</p> <p>B. Disconnect the primary speed/timing sensor. Disconnect the P2 ECM connector.</p> <p>C. Measure the resistance between pin 1 on the harness connector for the primary speed/timing sensor and P2:59.</p> <p>D. Measure the resistance between pin 2 on the harness connector for the primary speed/timing sensor and P2:44.</p>	<p>Less than 5 Ohms</p>	<p>Result: At least one of the resistance measurements is greater than 5 Ohms.</p> <p>The fault is in the wiring between the primary speed/timing sensor and the P2 connector.</p> <p>Check all wiring between the primary speed/timing sensor and the ECM. Refer to the appropriate Electrical Schematic. Replace the faulty wiring. Use the electronic service tool to clear all logged diagnostic codes and verify that the repair eliminates the fault.</p> <p>Result: Both resistance measurements are less than 5 Ohms.</p>

		Proceed to Test Step 10.
<p>5. Check the Sensor Supply Voltage at the Sensor Connector</p> <p>A. Turn the keyswitch to the OFF position.</p> <p>B. Disconnect the connector for the secondary speed/timing sensor.</p> <p>C. Turn the keyswitch to the ON position. Do not start the engine.</p> <p>D. Measure the voltage between pin 1 and pin 3 on the harness connector for the secondary speed/timing sensor.</p> <p>E. Turn the keyswitch to the OFF position.</p> <p>F. Reconnect the connector for the secondary speed/timing sensor.</p>	4.9 V to 5.1 V	<p>Result: The measured voltage is not within the expected range.</p> <p>The fault is in the wiring between the secondary speed/timing sensor and the P2 connector.</p> <p>Replace the faulty wiring. Use the electronic service tool to clear all logged diagnostic codes and verify that the repair eliminates the fault.</p> <p>Result: The measured voltage is within the expected range.</p> <p>Proceed to Test Step 6.</p>
<p>6. Check for Signal Voltage at the Sensor Connector</p> <p>A. Turn the keyswitch to the OFF position.</p> <p>B. Disconnect the connector for the secondary speed/timing sensor.</p> <p>C. Turn the keyswitch to the ON position. Do not attempt to start the engine.</p> <p>D. Measure the voltage between pin 1 and pin 2 on the harness connector for the secondary speed/timing sensor.</p> <p>E. Turn the keyswitch to the OFF position.</p> <p>F. Reconnect the secondary speed timing sensor.</p>	4.52 to 4.72 V	<p>Result: The measured voltage is within the expected range.</p> <p>Replace the secondary speed/timing sensor. Refer to Disassembly and Assembly, "Camshaft Position Sensor - Remove and Install" for the correct procedure. Start the engine. Use the electronic service tool to clear all logged diagnostic codes and verify that the repair eliminates the fault.</p> <p>Result: The measured voltage is not within the expected range.</p> <p>Proceed to Test Step 7.</p>
<p>7. Check the Sensor Signal Voltage at the ECM</p>	4.52 to 4.72	Result: The measured voltage is

<p>A. Turn the keyswitch to the OFF position.</p> <p>B. Disconnect the P2 connector.</p> <p>C. Turn the keyswitch to the ON position. Do not attempt to start the engine.</p> <p>D. Measure the voltage between J2:14 and J2:28 on the ECM.</p> <p>E. Turn the keyswitch to the OFF position.</p> <p>F. Reconnect the P2 connector.</p>	<p>V</p>	<p>within the expected range.</p> <p>The fault is in the sensor signal wire between the secondary speed/timing sensor and the P2 ECM connector.</p> <p>Check all wiring between the secondary speed/timing sensor and the ECM. Refer to the appropriate Electrical Schematic. Replace the faulty wiring. Use the electronic service tool to clear all logged diagnostic codes and verify that the repair eliminates the fault.</p> <p>Result: The measured voltage is not within the expected range.</p> <p>Proceed to Test Step 10.</p>
<p>8. Inspect the Sensors</p> <p>A. Ensure that the speed/timing sensors are correctly seated in the cylinder block and the front cover and that the retaining bolts are tightened to the correct torque. Refer to Disassembly and Assembly, "Crankshaft Position Sensor - Remove and Install" or refer to Disassembly and Assembly, "Camshaft Position Sensor - Remove and Install". Ensure that the speed/timing sensors are not damaged.</p> <p>B. Replace any damaged sensors. Refer to Disassembly and Assembly, "Crankshaft Position Sensor - Remove and Install" or refer to Disassembly and Assembly, "Camshaft Position Sensor - Remove and Install".</p> <p>C. Use the electronic service tool to check if the 637-11 diagnostic code is still active.</p>	<p>Diagnostic code</p>	<p>Result: A 637-11 diagnostic code is not active at this time.</p> <p>Use the electronic service tool to clear all logged diagnostic codes and verify that the repair eliminates the fault.</p> <p>Result: A 637-11 diagnostic code is still active at this time.</p> <p>Proceed to Test Step 9.</p>
<p>9. Check the Crankshaft Timing Ring and the Camshaft Position Wheel</p> <p>A. Inspect the crankshaft timing ring. Refer to Disassembly and Assembly, "Crankshaft Timing Ring - Remove and Install".</p>	<p>Defects</p>	<p>Result: Found fault with the crankshaft timing ring or the camshaft position wheel</p> <p>If necessary, replace the camshaft position wheel. Refer to Disassembly and Assembly,</p>

<p>B. Inspect the camshaft position wheel. Refer to Disassembly and Assembly, "Camshaft Gear - Remove and Install".</p>		<p>"Camshaft Gear - Remove and Install". If necessary, replace the crankshaft timing ring. Refer to Disassembly and Assembly, "Crankshaft Timing Ring - Remove and Install". Use the electronic service tool in order to clear all logged diagnostic codes and then verify that the repair has eliminated the fault.</p> <p>Result: No faults found.</p> <p>Contact the Dealer Solution Network (DSN).</p>
<p>10. Check if a Replacement ECM Eliminates the Fault</p> <p>A. Contact the DSN.</p> <p>B. If the DSN recommends the use of a replacement ECM, install a replacement ECM. Refer to Troubleshooting, "Replacing the ECM".</p> <p>C. Use the electronic service tool to recheck the system for active diagnostic codes.</p>	<p>Diagnostic codes</p>	<p>Result: There are no active diagnostic codes with the replacement ECM.</p> <p>Reconnect the suspect ECM. If the fault returns with the suspect ECM, replace the ECM. Use the electronic service tool in order to clear all logged diagnostic codes and then verify that the repair eliminates the fault.</p> <p>Result: The diagnostic code is still present with the replacement ECM.</p> <p>Contact the DSN.</p>

CAT C3.4B Engine Parts Contact phone: 269 673 1638
 Email: EngineParts@HeavyEquipmentRestorationParts.com
 Alternate email: engineparts2@gmail.com
 Website: www.CATC34B.com
 Related website: www.HeavyEquipmentRestorationParts.com
 www.FPTIndustrialEngineParts.com



Previous Screen



Troubleshooting

C3.4B Engines

Media Number -UENR0611-10

Publication Date -01/02/2015

i06577530

Switch Circuits - Test - Air Filter Restriction Switch

SMCS - 1435-038; 7332-038

Use this procedure to diagnose electronic faults in the air filter restriction switch circuit.

This procedure covers the following diagnostic code:

Table 1

Diagnostic Trouble Codes for the Air Filter Restriction Switch		
J1939 Code	Description	Notes
107-2	Engine Air Filter 1 Differential Pressure : Erratic, Intermittent, or Incorrect	<p>This code indicates a fault in the circuit for the air filter restriction switch.</p> <p>The Electronic Control Module (ECM) detects the following conditions: The signal from the air filter restriction switch indicates a restriction. The engine is not running. The ECM has been powered for at least 6 seconds.</p> <p>The warning lamp will come on. Monitoring of air filter restriction when the engine is running will be disabled whilst this code is active.</p>

If the engine is equipped with an air filter restriction switch, the type of switch that is installed can be either "Normally Open" or "Normally Closed". The parameter for the type of switch that is installed can be set using the electronic service tool.

Use the electronic service tool to check which type of switch is installed in the application before continuing with this procedure.

Ensure that the parameter is set correctly for the type of switch that is installed in the application. Refer to the OEM for more information.

Table 2

Diagnostic Summary for a "Normally Open" Air Filter Restriction Switch		
Engine Condition	Switch State	Active Diagnostic Code
Not running (key on)	Open	Normal condition
Running	Open	Normal Condition (no air filter restriction detected)
Not running	Closed	107-2
Running	Closed	107-15 or 107-16

Table 3

Diagnostic Summary for a "Normally Closed" Air Filter Restriction Switch		
Engine Condition	Switch State	Active Diagnostic Code
Not running (key on)	Open	107-2
Running	Open	107-15 or 107-16
Not running	Closed	Normal condition
Running	Closed	Normal Condition (no air filter restriction detected)

Note: An active 107–15 or 107–16 diagnostic code indicates that the air inlet is restricted. Refer to Troubleshooting, "Inlet Air Is Restricted".

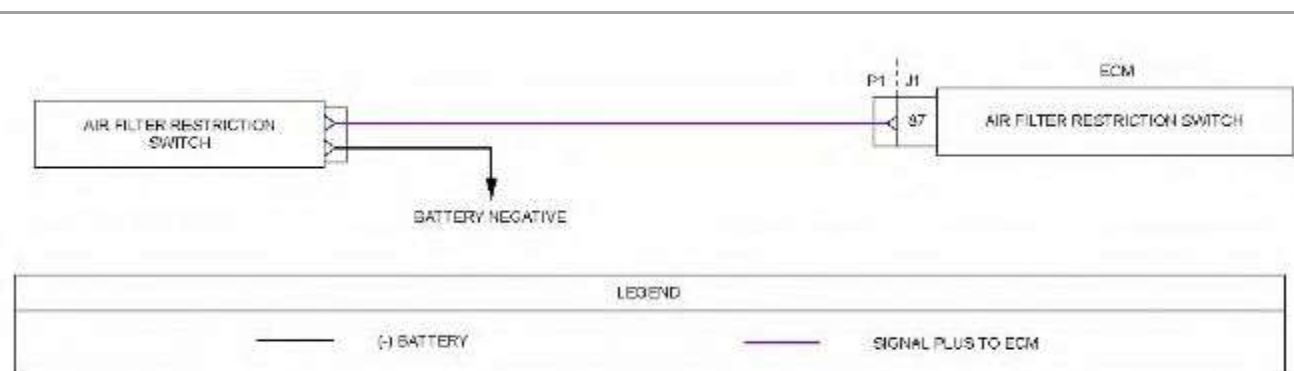

Illustration 1

g03636737

Schematic diagram for an air filter restriction switch
 Not all connectors are shown. Refer to the Electrical Schematic for the application.

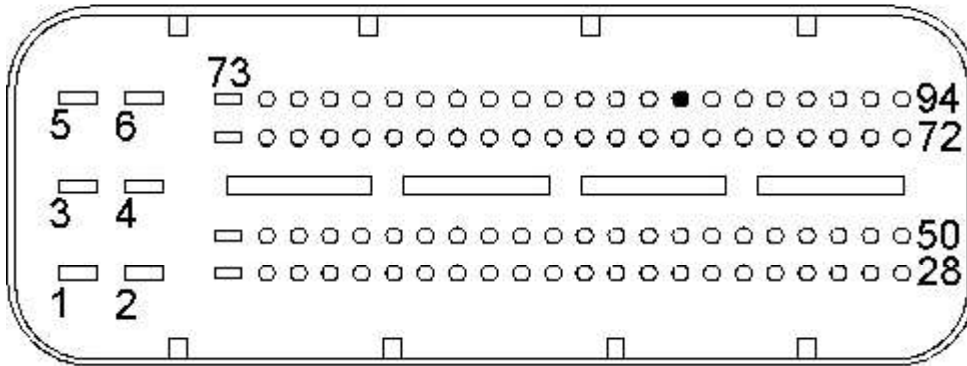

Illustration 2

g02716382

View of the pin location on the P1 connector for the air filter restriction switch
 (87) Air filter restriction switch

Table 4

Troubleshooting Test Steps	Values	Results
<p>1. Check the Type of Switch that is Installed and Configured</p> <p>A. Connect the electronic service tool to the diagnostic connector.</p> <p>B. Turn the keyswitch to the ON position. Do not start the engine.</p> <p>C. Use the electronic service tool to check that the "Air Filter Restriction Switch Installation Status" and the "Air Filter Restriction Switch Configuration" matches the type of switch that is installed.</p>	<p>Switch configuration</p>	<p>Result: An air filter restriction switch is installed and the "Air Filter Restriction Switch Installation Status" is "Not Installed".</p> <p>Use the electronic service tool to change the "Air Filter Restriction Switch Installation Status" to "Installed". Ensure that the "Air Filter Restriction Switch Configuration" matches the type of switch that is installed. Use the electronic service to check that the repair eliminates the fault.</p> <p>Result: An air filter restriction switch is not installed and the "Air Filter Restriction Switch Installation Status" is "Not Installed". The "Air Filter Restriction Switch Configuration" is "Normally Closed".</p>

		<p>Repair: Change the "Air Filter Restriction Switch Configuration" to "Normally Open." Use the electronic service to check that the repair eliminates the fault.</p> <p>Result: An air filter is installed and the "Air Filter Restriction Switch Installation Status" is installed. The "Air Filter Restriction Switch Configuration" does not match the type of switch that is installed.</p> <p>Repair: Change the "Air Filter Restriction Switch Configuration" to match the type of switch that is installed. Use the electronic service to check that the repair eliminates the fault.</p> <p>Result: An air filter restriction switch is installed. The "Air Filter Restriction Switch Installation Status" is "Installed". The "Air Filter Restriction Switch Configuration" matches the type of switch that is installed.</p> <p>Proceed to Test Step 2.</p>
<p>2. Inspect Electrical Connectors and Wiring</p> <p>A. Thoroughly inspect the terminal connections on the P1/J1 connector.</p> <p>B. Thoroughly inspect the connector for the air filter restriction switch.</p> <p>C. Refer to Troubleshooting, "Electrical Connectors - Inspect".</p> <p>D. Perform a 30 N (6.7 lb) pull test on each of the wires in the connectors that are associated with the air filter restriction switch.</p> <p>E. Check the harness for abrasions and for pinch points from the switch back to the ECM.</p>	<p>Damaged wire or connector</p>	<p>Result: A damaged wire or damaged connector was found.</p> <p>Repair: Repair the damaged wire or the damaged connector. Use the electronic service tool to clear all logged diagnostic codes. Verify that the repair eliminates the fault.</p> <p>Result: All connectors, pins, and sockets are correctly connected and/or inserted and the harness is free of corrosion, of abrasion or of pinch points.</p> <p>Proceed to Test Step 3.</p>

<p>3. Check for Active or Recently Logged Diagnostic Codes</p> <p>A. Turn the keyswitch to the OFF position.</p> <p>B. Connect the electronic service tool to the diagnostic connector.</p> <p>C. Turn the keyswitch to the ON position. Do not start the engine.</p> <p>D. Use the electronic service tool to check whether a "Normally Open" or "Normally Closed" air filter restriction switch is installed in the application.</p> <p>E. Check for any active or recently logged diagnostic codes. Wait at least 10 seconds for activation of the diagnostic codes.</p>	<p>Diagnostic codes</p>	<p>Result: A 107-2 diagnostic code is not active. If the diagnostic code is recently logged, an intermittent fault may exist.</p> <p>Repair: Refer to Troubleshooting, "Electrical Connectors - Inspect" to identify intermittent faults.</p> <p>Result: A "Normally Open" switch is installed. A 107-2 diagnostic code is active. A short circuit condition exists in the air filter restriction switch circuit.</p> <p>Proceed to Test Step 4.</p> <p>Result: A "Normally Closed" switch is installed. A 107-2 diagnostic code is active. An open circuit condition exists in the air filter restriction switch circuit.</p> <p>Proceed to Test Step 6.</p>
<p>4. Create an Open Circuit at the Switch Connector</p> <p>A. Turn the keyswitch to the OFF position.</p> <p>B. Disconnect the connector from the air filter restriction switch.</p> <p>C. Turn the keyswitch to the ON position. Do not start the engine.</p> <p>D. Use the electronic service tool to check for an active 107-2 diagnostic code. Wait at least 10 seconds for activation of the diagnostic code.</p> <p>E. Turn the keyswitch to the OFF position.</p>	<p>Diagnostic codes</p>	<p>Result: The fault is cleared with the switch disconnected.</p> <p>Repair: Replace the air filter restriction switch. Use the electronic service tool to clear all logged diagnostic codes and verify that the repair eliminates the fault.</p> <p>Result: The 107-2 diagnostic code is still active with the air filter restriction switch disconnected.</p> <p>Reconnect the connector to the air filter restriction switch and proceed to Test Step 5.</p>
<p>5. Check the Wiring for a Short Circuit</p>	<p>Greater than 1 k Ohm</p>	<p>Result: At least one of the resistance measurements is less than 1 k Ohm</p>

<p>A. Turn the keyswitch to the OFF position.</p> <p>B. Disconnect the connector for the switch. Disconnect the P1 connector from the ECM.</p> <p>C. Use a suitable multimeter to measure the resistance between P1:87 and all other terminals on the P1 connector.</p>		<p>The fault is in the wiring between the air filter restriction switch and the P1 ECM connector.</p> <p>Repair: Check all wiring between the switch and the ECM. Refer to the Electrical Schematic for the application. Replace the faulty wiring. Use the electronic service tool to clear all logged diagnostic codes and verify that the repair eliminates the fault.</p> <p>Result: All resistance measurements are greater than 1 k Ohm.</p> <p>Contact the Dealer Solution Network (DSN).</p>
<p>6. Create a Short at the Switch Connector</p> <p>A. Turn the keyswitch to the OFF position.</p> <p>B. Disconnect the connector from the air filter restriction switch.</p> <p>C. Fabricate a jumper wire and install the jumper wire across the two terminals on the harness connector for the switch.</p> <p>D. Turn the keyswitch to the ON position.</p> <p>E. Use the electronic service tool to check for an active 107-2 diagnostic code. Wait at least 10 seconds for activation of the diagnostic code.</p> <p>F. Turn the keyswitch to the OFF position.</p> <p>G. Remove the jumper wire.</p>	<p>Diagnostic code</p>	<p>Result: The fault is cleared with the jumper installed.</p> <p>Repair: Replace the air filter restriction switch. Use the electronic service tool to clear all logged diagnostic codes and verify that the repair eliminates the fault.</p> <p>Result: A 107-2 diagnostic code is still active with the jumper installed.</p> <p>Proceed to Test Step 7.</p>
<p>7. Check the Ground Wire for the Switch</p>	<p>Diagnostic code</p>	<p>Result: The fault is cleared with the jumper installed.</p> <p>The fault is in the ground wire between the</p>

<p>A. Turn the keyswitch to the OFF position.</p> <p>B. Disconnect the connector from the air filter restriction switch.</p> <p>C. Fabricate a jumper wire. Install the jumper wire between the signal terminal on the harness connector for the switch and a suitable ground.</p> <p>D. Turn the keyswitch to the ON position.</p> <p>E. Use the electronic service tool to check for an active 107-2 diagnostic code. Wait at least 10 seconds for activation of the diagnostic code.</p> <p>F. Turn the keyswitch to the OFF position.</p> <p>G. Remove the jumper wire.</p>		<p>air filter restriction switch and battery negative.</p> <p>Repair: Check all wiring between the switch and the ECM. Refer to the Electrical Schematic for the application. Replace the faulty wiring. Use the electronic service tool to clear all logged diagnostic codes and verify that the repair eliminates the fault.</p> <p>Result: A 107-2 diagnostic code is active with the jumper installed.</p> <p>Proceed to Test Step 8.</p>
<p>8. Check the Wiring for an Open Circuit</p> <p>A. Turn the keyswitch to the OFF position.</p> <p>B. Disconnect the connector for the switch. Disconnect the P1 connector from the ECM.</p> <p>C. Use a suitable multimeter to measure the resistance between P1:87 and the signal terminal on the harness connector for the switch.</p>	<p>Less than 5 Ohms</p>	<p>Result: The measured resistance is greater than 5 Ohms. There is an open circuit or high resistance in the wiring between the air filter restriction switch and the ECM.</p> <p>Repair: Check all wiring between the switch and the ECM. Refer to the Electrical Schematic for the application. Replace the faulty wiring. Use the electronic service tool to clear all logged diagnostic codes and verify that the repair eliminates the fault.</p> <p>Result: The measured resistance is less than 5 Ohms.</p> <p>Contact the Dealer Solution Network (DSN).</p>



Previous Screen



Troubleshooting

C3.4B Engines

Media Number -UENR0611-10

Publication Date -01/02/2015

i06019874

Switch Circuits - Test - Engine Oil Pressure Switch

SMCS - 1435-038; 7332-038

Use this procedure to diagnose electronic faults in the oil pressure switch circuit.

This procedure covers the following diagnostic code:

Table 1

Diagnostic Trouble Codes for the Oil Pressure Switch		
J1939 Code	Description	Notes
100-2	Engine Oil Pressure : Erratic, Intermittent, or Incorrect	When the keyswitch is in the ON position (engine not running), the oil pressure switch circuit should be closed. This diagnostic code will be active when the Electronic Control Module (ECM) detects the following conditions: The engine is not running. The circuit for the oil pressure switch is open for at least 3 seconds. The keyswitch has been switched on for at least 6 seconds. The battery voltage is at least 10 VDC.

The engine is equipped with an oil pressure switch. While the engine is running and oil pressure is detected, the switch will be open. When no oil pressure is detected, the switch will be closed.

Table 2

Oil Pressure Switch States and Diagnostics Summary		
Engine Condition	Oil Pressure Switch State	Active Diagnostic Code

Not running	Closed	Normal condition (no oil pressure detected)
Running	Open	Normal condition (oil pressure detected)
Not running	Open	100-2
Running	Closed	100-17

Note: If a 100-17 diagnostic code is active, refer to Troubleshooting, "Oil Pressure Is Low" before returning to this procedure.

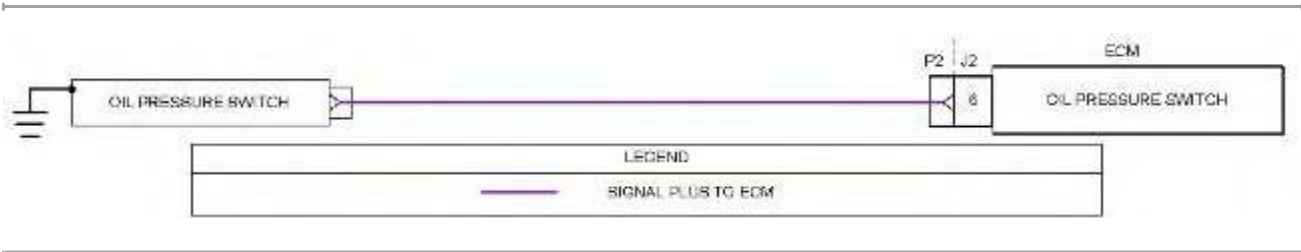

Illustration 1

g03636596

Schematic diagram for the oil pressure switch

Not all connectors are shown. Refer to the appropriate Electrical Schematic.

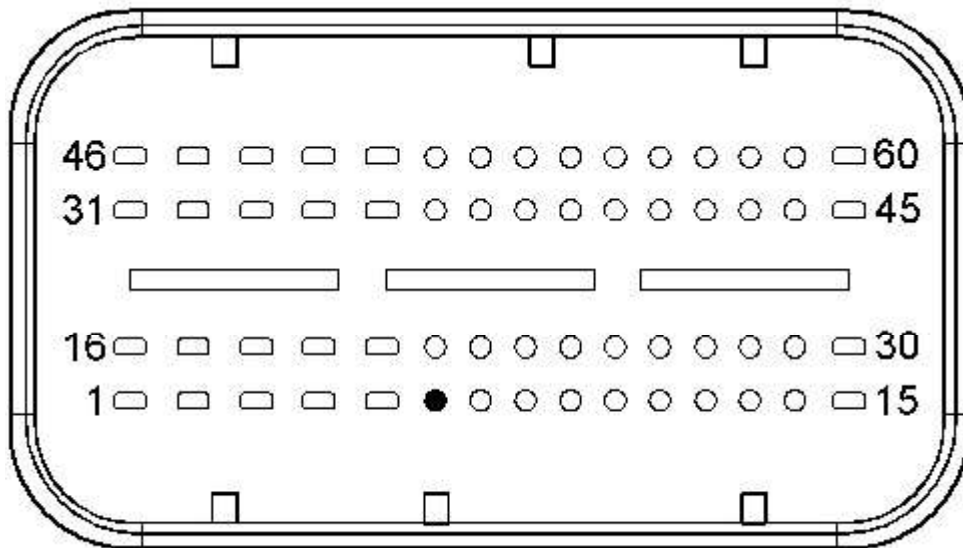

Illustration 2

g02710319

View of the pin location on the P2 connector for the oil pressure switch

(6) Engine oil pressure switch

Table 3

Troubleshooting Test Steps	Values	Results

<p>1. Inspect Electrical Connectors and Wiring</p> <p>A. Thoroughly inspect the terminal connections on the P2/J2 connector.</p> <p>B. Thoroughly inspect the connector for the oil pressure switch.</p> <p>C. Refer to Troubleshooting, "Electrical Connectors - Inspect".</p> <p>D. Perform a 30 N (6.7 lb) pull test on each of the wires in the connectors that are associated with the oil pressure switch.</p> <p>E. Check the harness for abrasions and for pinch points from the oil pressure switch back to the ECM.</p>	<p>Damaged wire or connector</p>	<p>Result: A damaged wire or damaged connector was found.</p> <p>Repair the damaged wire or the damaged connector.</p> <p>Use the electronic service tool to clear all logged diagnostic codes. Verify that the repair eliminates the fault.</p> <p>Result: All connectors, pins, and sockets are correctly connected and/or inserted and the harness is free of corrosion, of abrasion or of pinch points.</p> <p>Proceed to Test Step 2.</p>
<p>2. Check for Active or Recently Logged Diagnostic Codes</p> <p>A. Turn the keyswitch to the OFF position.</p> <p>B. Connect the electronic service tool to the diagnostic connector.</p> <p>C. Turn the keyswitch to the ON position. Do not start the engine.</p> <p>D. Check for any active or recently logged diagnostic codes. Wait at least 10 seconds for activation of the diagnostic codes.</p>	<p>Diagnostic codes</p>	<p>Result: A 100-17 diagnostic code is recently logged.</p> <p>This diagnostic code indicates that the oil pressure is low, but can also be caused by a short circuit condition in the oil pressure switch circuit.</p> <p>Check for engine oil pressure problems before returning to this procedure. refer to Troubleshooting, "Oil Pressure Is Low". If the fault is still present, proceed to Test Step 3.</p> <p>Result: A 100-2 diagnostic code is not active. A 100-17 diagnostic code is not recently logged.</p> <p>An intermittent 100-2 diagnostic code can be caused by turning the keyswitch to the ON position after the engine has recently been stopped or an intermittent fault may exist.</p> <p>Refer to Troubleshooting, "Electrical Connectors - Inspect" in order to identify intermittent faults.</p> <p>Result: A 100-2 diagnostic code is active.</p>

		Proceed to Test Step 5.
<p>3. Create an Open Circuit at the Switch Connector</p> <p>A. Turn the keyswitch to the OFF position.</p> <p>B. Disconnect the harness connector for the oil pressure switch.</p> <p>C. Turn the keyswitch to the ON position. Do not start the engine.</p> <p>D. Use the electronic service tool to check for an active 100-2 diagnostic code. Wait at least 10 seconds for activation of the diagnostic code.</p>	Diagnostic codes	<p>Result: A 100-2 diagnostic code is active with the switch disconnected.</p> <p>Replace the oil pressure switch. Refer to Disassembly and Assembly, "Engine Oil Pressure Switch - Remove and Install". Use the electronic service tool to clear all logged diagnostic codes and verify that the repair eliminates the fault.</p> <p>Result: A 100-2 diagnostic code is not active with the oil pressure switch disconnected.</p> <p>Reconnect the harness connector for the oil pressure switch and proceed to Test Step 4.</p>
<p>4. Create an Open Circuit at the ECM Connector</p> <p>A. Disconnect the P2 connector from the ECM.</p> <p>B. Turn the keyswitch to the ON position. Do not attempt to start the engine. Wait at least 30 seconds for activation of the diagnostic codes.</p> <p>C. Use the electronic service tool to check for an active 100-2 diagnostic code. Note: Diagnostic codes for all of the engine sensors will be active with the P2 connector disconnected. Ignore all other codes and only look for a 100-2 diagnostic code.</p> <p>D. Turn the keyswitch to the OFF position.</p>	Diagnostic codes	<p>Result: A 100-2 diagnostic code is active with the P2 connector disconnected.</p> <p>The fault is in the wiring between the oil pressure switch and the P2 ECM connector. Check all wiring between the oil pressure switch and the ECM. Refer to the appropriate Electrical Schematic. Replace the faulty wiring. Use the electronic service tool to clear all logged diagnostic codes and verify that the repair eliminates the fault.</p> <p>Result: A 100-2 diagnostic code is not active with the wire disconnected.</p> <p>Proceed to Test Step 7.</p>
<p>5. Create a Short at the Switch Connector</p> <p>A. Turn the keyswitch to the OFF position.</p>	Diagnostic codes	<p>Result: A 100-2 diagnostic code is not active with the jumper installed.</p> <p>Replace the oil pressure switch. Refer to</p>

<p>B. Disconnect the harness connector for the oil pressure switch.</p> <p>C. Fabricate a jumper wire and install the jumper wire between the harness connector for the oil pressure switch and a suitable ground.</p> <p>D. Turn the keyswitch to the ON position. Do not start the engine.</p> <p>E. Use the electronic service tool to check for an active 100-2 diagnostic code. Wait at least 10 seconds for activation of the diagnostic code.</p> <p>F. Turn the keyswitch to the OFF position.</p> <p>G. Remove the jumper wire.</p>		<p>Disassembly and Assembly, "Engine Oil Pressure Switch - Remove and Install". Use the electronic service tool to clear all logged diagnostic codes and verify that the repair eliminates the fault.</p> <p>Result: A 100-2 diagnostic code is active with the jumper installed.</p> <p>Proceed to Test Step 6.</p>
<p>6. Create a Short at the ECM Connector</p> <p>A. Turn the keyswitch to the OFF position.</p> <p>B. Disconnect the P2 connector from the ECM.</p> <p>C. Fabricate a jumper wire and install the jumper wire between J2:6 and a suitable ground.</p> <p>D. Turn the keyswitch to the ON position. Do not attempt to start the engine. Wait at least 30 seconds for activation of the diagnostic codes.</p> <p>E. Use the electronic service tool to check for an active 100-2 diagnostic code. Note: Diagnostic codes for all of the engine sensors will be active with the P2 connector disconnected. Ignore all other codes and only look for a 100-2 diagnostic code.</p> <p>F. Turn the keyswitch to the OFF position.</p> <p>G. Remove the jumper wire.</p>	<p>Diagnostic Codes</p>	<p>Result: A 100-2 diagnostic code is not active with the jumper installed.</p> <p>The fault is in the wiring between the oil pressure switch and the P2 ECM connector. Check all wiring between the oil pressure switch and the ECM. Refer to the appropriate Electrical Schematic. Replace the faulty wiring. Use the electronic service tool to clear all logged diagnostic codes and verify that the repair eliminates the fault.</p> <p>Result: A 100-2 diagnostic code is active with the jumper installed.</p> <p>Proceed to Test Step 7.</p>

<p>7. Check if a Replacement ECM Eliminates the Fault</p> <p>A. Contact the Dealer Solution Network (DSN).</p> <p>B. If the DSN recommends the use of a replacement ECM, install a replacement ECM. Refer to Troubleshooting, "Replacing the ECM".</p> <p>C. Use the electronic service tool to recheck the system for active diagnostic codes.</p>	<p>Diagnostic codes</p>	<p>Result: There are no active diagnostic codes with the replacement ECM.</p> <p>Reconnect the suspect ECM. If the fault returns with the suspect ECM, replace the ECM.</p> <p>Use the electronic service tool in order to clear all logged diagnostic codes and then verify that the repair eliminates the fault.</p> <p>Result: The diagnostic code is still present with the replacement ECM.</p> <p>Contact the DSN.</p>
--	-------------------------	--

CAT C3.4B Engine Parts
Contact phone: 269 673 1638
Email: EngineParts@HeavyEquipmentRestorationParts.com
Alternate email: engineparts2@gmail.com
Website: www.CATC34B.com
Related website: www.HeavyEquipmentRestorationParts.com
www.FPTIndustrialEngineParts.com



Previous Screen



Troubleshooting

C3.4B Engines

Media Number -UENR061.1-10

Publication Date -01/02/2015

i06233842

Switch Circuits - Test - Throttle Switch

SMCS - 1435-038; 7332-038

Table 1

Diagnostic Trouble Codes for the Throttle Switch Circuit		
J1939 Code	Description	Notes
2880-2	Engine Operator Primary Intermediate Speed Select : Erratic, Intermittent, or Incorrect	<p>The Electronic Control Module (ECM) detects the following conditions:</p> <p>The signal voltage from the throttle switch is between 0.35 V and 4.8 V.</p> <p>The signal voltage from the throttle switch is not valid for any of the available modes for at least 0.5 seconds.</p> <p>The battery voltage is at least 10 V.</p> <p>The warning lamp will come on.</p>
2880-3	Engine Operator Primary Intermediate Speed Select : Voltage Above Normal	<p>The ECM detects the following conditions:</p> <p>The signal voltage from the throttle switch is above 4.8 VDC for at least 0.5 seconds.</p> <p>The battery voltage is at least 10 VDC.</p> <p>The warning lamp will come on.</p>
2880-4	Engine Operator Primary Intermediate Speed Select : Voltage Below Normal	<p>The ECM detects the following conditions:</p> <p>The signal voltage from the throttle switch is less than 0.35 VDC for at least 0.5 seconds.</p>

The battery voltage is at least 10 VDC.

The warning lamp will come on.

The throttle switch uses resistors to modify the voltage signal from the ECM. The resistance of the switch changes dependent on which position the switch is in. The ECM uses the signal voltage to determine which mode has been selected.

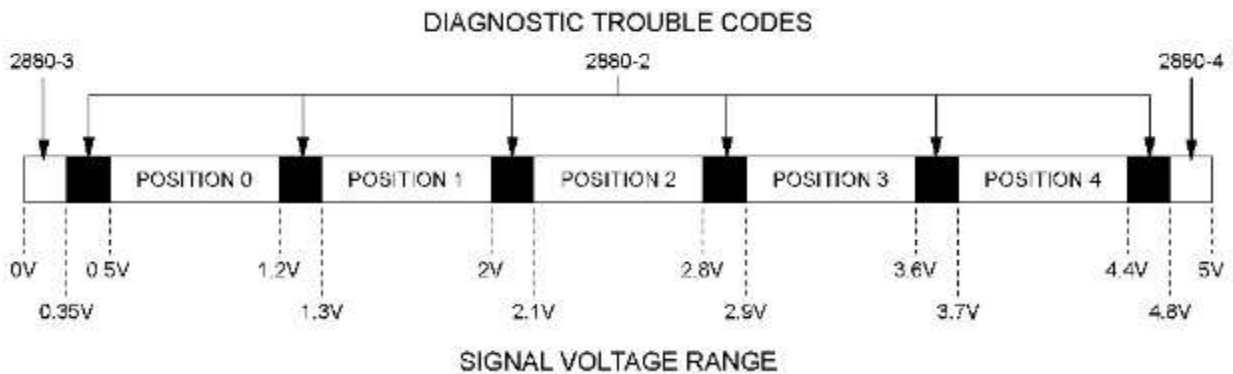

Illustration 1

g03117957

View of the signal voltage range for the throttle switch

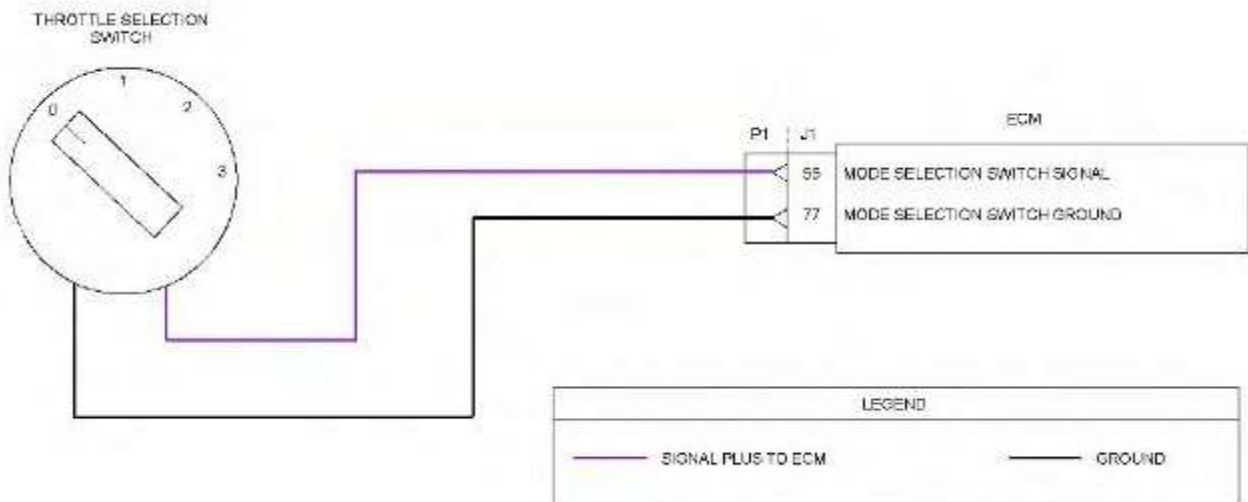

Illustration 2

g03734117

Typical example of the schematic for the throttle switch

Not all connectors are shown. Refer to the Electrical Schematic for the application.

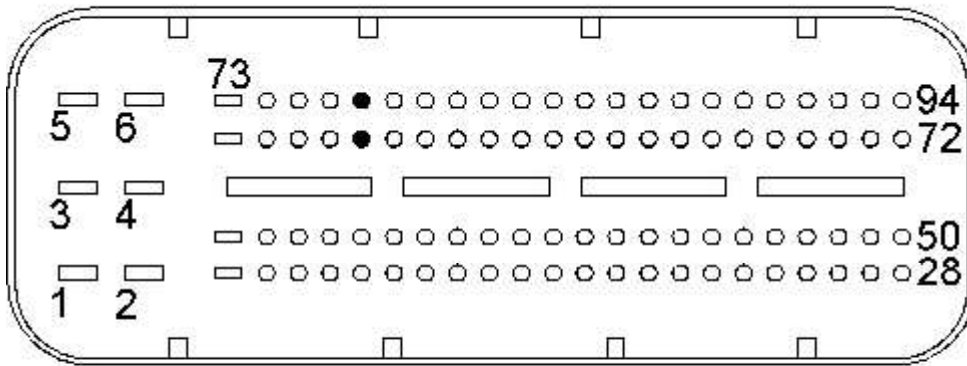

Illustration 3

g02723018

Typical view of the pin locations on the P1 connector for the throttle switch
 (55) Throttle switch signal
 (77) Throttle switch ground

Table 2

Troubleshooting Test Steps	Values	Results
<p>1. Inspect Electrical Connectors and Wiring</p> <p>A. Thoroughly inspect the terminal connections on the P1/J1 connector.</p> <p>B. Thoroughly inspect the connector for the throttle switch.</p> <p>C. Refer to Troubleshooting, "Electrical Connectors - Inspect".</p> <p>D. Perform a 30 N (6.7 lb) pull test on each of the wires in the connectors that are associated with the throttle switch.</p> <p>E. Check the harness for abrasions and for pinch points from the switch back to the ECM.</p>	<p>Damaged wire or connector</p>	<p>Result: A damaged wire or damaged connector was not found.</p> <p>Proceed to Test Step 2.</p> <p>Result: A damaged wire or damaged connector was found.</p> <p>Repair: Repair the damaged wire or the damaged connector. Use the electronic service tool to clear all logged diagnostic codes. Verify that the repair eliminates the fault.</p>
<p>2. Check for Active or Recently Logged Diagnostic Codes</p>	<p>Diagnostic</p>	<p>Result: A 2880-4 diagnostic code is active.</p>

<p>A. Turn the keyswitch to the OFF position.</p> <p>B. Connect the electronic service tool to the diagnostic connector.</p> <p>C. Turn the keyswitch to the ON position. Do not start the engine.</p> <p>D. Check for active diagnostic codes with the throttle switch in each position. Wait at least 10 seconds with the switch in each position for activation of the diagnostic codes.</p>	<p>Trouble Codes</p>	<p>Proceed to Test Step 3.</p> <p>Result: A 2880-3 diagnostic code is active.</p> <p>Proceed to Test Step 4.</p> <p>Result: A 2880-2 diagnostic code is active.</p> <p>Proceed to Test Step 5.</p>
<p>3. Create an Open Circuit at the Switch</p> <p>A. Turn the keyswitch to the OFF position.</p> <p>B. Disconnect the throttle switch.</p> <p>C. Turn the keyswitch to the ON position.</p> <p>D. Use the electronic service tool to check for an active 2880 diagnostic code. Wait at least 10 seconds for activation of the diagnostic codes.</p> <p>E. Turn the keyswitch to the OFF position.</p>	<p>Diagnostic codes</p>	<p>Result: A 2880-3 diagnostic code is active with the switch disconnected.</p> <p>Repair: Replace the throttle switch. Use the electronic service tool to clear all logged diagnostic codes and verify that the repair eliminates the fault.</p> <p>Result: A 2880-4 diagnostic code is still active with the switch disconnected.</p> <p>Reconnect the switch and proceed to Test Step 7.</p>
<p>4. Create a Short at the Switch Connector</p> <p>A. Turn the keyswitch to the OFF position.</p> <p>B. Disconnect the throttle switch.</p> <p>C. Fabricate a jumper wire and install the jumper wire between the two harness connector terminals for the throttle switch.</p> <p>D. Turn the keyswitch to the ON position.</p> <p>E. Use the electronic service tool to check for an active 2880 diagnostic code. Wait at least 10 seconds for activation of the diagnostic codes.</p>	<p>Diagnostic codes</p>	<p>Result: A 2880-4 diagnostic code is active with the jumper installed.</p> <p>Repair: Replace the throttle switch. Use the electronic service tool to clear all logged diagnostic codes and verify that the repair eliminates the fault.</p> <p>Result: A 2880-3 diagnostic code is still active with the jumper installed.</p> <p>Reconnect the throttle switch and proceed to Test Step 7.</p>

<p>F. Turn the keyswitch to the OFF position.</p> <p>G. Remove the jumper wire.</p>		
<p>5. Check the Voltage at the Switch Connector</p> <p>A. Turn the keyswitch to the OFF position.</p> <p>B. Disconnect the throttle switch.</p> <p>C. Turn the keyswitch to the ON position.</p> <p>D. Use a suitable multimeter to measure the voltage between the signal terminal and the ground terminal at the switch connector.</p> <p>E. Turn the keyswitch to the OFF position.</p>	<p>4.9 V to 5.1 V</p>	<p>Result: The voltage is within the expected range.</p> <p>Repair: Replace the throttle switch. Use the electronic service tool to clear all logged diagnostic codes and verify that the repair eliminates the fault.</p> <p>Result: The voltage is not within the expected range.</p> <p>Proceed to Test Step 6.</p>
<p>6. Check the Wiring for High Resistance</p> <p>A. Turn the keyswitch to the OFF position.</p> <p>B. Disconnect the throttle switch. Disconnect the P1 connector.</p> <p>C. Use a suitable multimeter to measure the resistance between the following points:</p> <ul style="list-style-type: none"> · P1:55 to the signal terminal at the switch connector · P1:77 to the ground terminal at the switch connector 	<p>Less than 5 Ohms</p>	<p>Result: At least one of the resistance measurements is greater than 5 Ohms. The fault is in the wiring between the switch connector and the P1 connector.</p> <p>Repair: Check all wiring between the throttle switch and the ECM. Refer to the Electrical Schematic for the application. Replace the faulty wiring. Use the electronic service tool to clear all logged diagnostic codes and verify that the repair eliminates the fault.</p> <p>Result: Both resistance measurements are less than 5 Ohms.</p> <p>Proceed to Test Step 7.</p>
<p>7. Check the Wiring for a Short Circuit</p> <p>A. Turn the keyswitch to the OFF position.</p>	<p>Greater than 1 k Ohm</p>	<p>Result: At least one of the resistance measurements is less than 1 k Ohm. There is a short in the wiring between the throttle switch and the</p>

B. Disconnect the P1 connector from the ECM.

C. Disconnect the throttle switch.

D. Use a suitable multimeter to measure the resistance between the following points:

- P1:55 and all other terminals on the P1 connector
- P1:77 and all terminals on the P1 connector

P1 connector.

Repair: Check all wiring between the throttle switch and the ECM. Refer to the Electrical Schematic for the application.

Replace the faulty wiring.

Use the electronic service tool to clear all logged diagnostic codes and verify that the repair eliminates the fault.

Result: All resistance measurements are greater than 1 k Ohm.

Contact the Dealer Solution Network (DSN).

CAT C3.4B Engine Parts

Contact phone: 269 673 1638

Email: EngineParts@HeavyEquipmentRestorationParts.com

Alternate email: engineparts2@gmail.com

Website: www.CATC34B.com

Related website: www.HeavyEquipmentRestorationParts.com

www.FPTIndustrialEngineParts.com



Troubleshooting

C3.4B Engines

Media Number -UENR0611-10

Publication Date -01/02/2015

i05980308

System Overview

SMCS - 1000; 1900

The engine is designed for electronic control of most engine operating functions. The electronic system consists of an Electronic Control Module (ECM), the wiring harness, switches, sensors, and fuel injectors. The engine ECM receives information from the sensors and the switches on the engine. The engine ECM processes the information that is collected in order to control the engine. By altering the fuel delivery with the fuel injectors, the engine ECM controls the speed and the power that is produced by the engine.

The following information provides a general description of the control system. Refer to the Systems Operation manual for detailed information about the control system.

System Operation

Engine Governor

The ECM governs the engine. The ECM determines the timing, the injection pressure, and the amount of fuel that is delivered to each cylinder. These factors are based on the actual conditions and on the desired conditions at any given time during starting and operation.

The ECM uses the throttle position sensor to determine the desired engine speed. The ECM compares the desired engine speed to the actual engine speed. The actual engine speed is determined through interpretation of the signals that are received by the ECM from the engine speed/timing sensors. If the desired engine speed is greater than the actual engine speed, the ECM requests that more fuel is injected in order to increase engine speed.

Timing Considerations

Once the ECM has determined the amount of fuel that is required, the ECM must determine the timing of the fuel injection.

The ECM adjusts timing for optimum engine performance and for the fuel economy. Actual timing and desired timing cannot be viewed with the electronic service tool. The ECM determines the location of top center of the number one cylinder from the signals that are provided by the

engine speed/timing sensors. The ECM determines when injection should occur relative to the top center. The ECM then provides the signal to the injector at the desired time.

Fuel Injection

The ECM sends a high voltage signal to the injector solenoids in order to energize the solenoids. By controlling the timing and the duration of the high voltage signal, the ECM can control the following aspects of injection:

- Injection timing
- Fuel delivery

Other ECM Functions for Performance

Refer to Troubleshooting, "Configuration Parameters" for supplemental information about the systems that can be monitored by the ECM.

Programmable Parameters

Certain parameters that affect engine operation may be changed with the electronic service tool. The parameters are stored in the ECM. These parameters are either system configuration parameters or customer parameters.

System configuration parameters are set at the factory. System configuration parameters affect emissions or power ratings within an engine family.

Some of the parameters may affect engine operation in an unusual way. An operator might not expect this type of effect. Without adequate training, these parameters may lead to power complaints or performance complaints even though the engine's performance is to the specification.

Customer parameters are variable. Customer parameters can be used to affect the characteristics of the engine. Limits are set by the factory and by the monitoring system.

Refer to Troubleshooting, "Configuration Parameters" for additional information on this subject.



Previous Screen



Troubleshooting

C3.4B Engines

Media Number -UENR061.1-10

Publication Date -01/02/2015

i06228923

Valve Lash Is Excessive

SMCS - 1105-035

Probable Causes

- Lubrication
- Valve train components

Recommended Actions

Note: The procedures have been listed in order of probability. Complete the procedures in order.

Table 1

Troubleshooting Test Steps	Values	Results
<p>1. Lubrication</p> <p>A. Remove the valve mechanism cover. Refer to Disassembly and Assembly, "Valve Mechanism Cover - Remove and Install" for the correct procedure.</p> <p>B. Crank the engine and check the lubrication in the valve compartment. Ensure that there is adequate engine oil flow in the valve compartment. The passages for the engine oil must be clean.</p> <p>Note: Do not run the engine with the valve mechanism cover removed.</p>	<p>Lubrication</p>	<p>Result: The oil flow to the valve mechanism is insufficient.</p> <p>Repair: Make sure that the passages for the engine oil are clear.</p> <p>Result: The oil flow to the valve mechanism is OK.</p> <p>Proceed to Test Step 2.</p>

<p>2. Valve Train Components</p> <p>A. Inspect the following components of the valve train for abnormal or excessive wear, straightness, and cleanliness:</p> <ul style="list-style-type: none"> · Rocker arms · Pushrods · Hydraulic lifters · Camshaft · Valve stems · Rocker shafts 	<p>Valve train components</p>	<p>Result: A valve train component is worn, bent, or not clean.</p> <p>Repair: Repair or replace the component. Refer to Disassembly and Assembly.</p> <p>Note: If the camshaft is replaced, new valve lifters must also be installed.</p> <p>Result: All the valve train components are OK.</p> <p>Contact the Dealer Solution Network (DSN).</p>
--	-------------------------------	--

CAT C3.4B Engine Parts
 Contact phone: 269 673 1638
 Email: EngineParts@HeavyEquipmentRestorationParts.com
 Alternate email: engineparts2@gmail.com
 Website: www.CATC34B.com
 Related website: www.HeavyEquipmentRestorationParts.com
www.FPTIndustrialEngineParts.com



Previous Screen



Troubleshooting

C3.4B Engines

Media Number -UENR0611-10

Publication Date -01/02/2015

i06020913

Valve Position - Test

SMCS - 108A-038-PSN; 1130-038-PSN; 1439-038-PSN

This procedure covers the following codes:

Table 1

Diagnostic Trouble Codes for the Valve Position Sensors		
J1939 Code	Description	Notes
27-3	Engine Exhaust Gas Recirculation Valve Position : Voltage Above Normal	<p>The Electronic Control Module (ECM) detects that the signal voltage from the position sensor on the NOx Reduction System (NRS) valve is greater than 4.8 VDC for at least 0.5 seconds.</p> <p>The battery voltage is at least 10 VDC.</p> <p>The ECM will set the valve to the default position while this code is active. The default position is 0 percent.</p> <p>The engine will be derated.</p>
27-4	Engine Exhaust Gas Recirculation Valve Position : Voltage Below Normal	<p>The ECM detects that the signal voltage from the position sensor on the NRS valve is less than 0.2 VDC for at least 0.5 seconds.</p> <p>The battery voltage is at least 10 VDC.</p> <p>The ECM will set the valve to the default position while this code is active. The default position is 0 percent.</p>

		The engine will be derated.
51-3	Engine Throttle Valve 1 Position : Voltage Above Normal	<p>The ECM detects the following conditions:</p> <p>The signal voltage from the position sensor on the intake throttle valve is greater than 4.75 VDC for at least 0.5 seconds.</p> <p>The battery voltage is at least 10 VDC.</p> <p>The intake throttle valve will move to the default position while the diagnostic code is active. The default position is 0 percent.</p>
51-4	Engine Throttle Valve 1 Position : Voltage Below Normal	<p>The ECM detects the following conditions:</p> <p>The signal voltage from the position sensor on the intake throttle valve is less than 0.25 VDC for at least 0.5 seconds.</p> <p>The intake throttle valve will move to the default position while the diagnostic code is active. The default position is 0 percent.</p>

Use this procedure in order to troubleshoot the position sensors for the following valves:

- NRS valve
- Engine intake throttle valve

Each position sensor is an integral part of the associated valve. If the following procedure indicates a fault with the position sensor, then the entire valve must be replaced.

The following background information is related to this procedure:

The troubleshooting procedures for the diagnostic codes of each position sensor are identical. The ECM supplies 5 VDC to terminal "1" of the engine intake throttle valve connector and to terminal "6" of the NRS valve connector. The sensor common from the ECM connector goes to terminal "3" of the engine intake throttle valve connector and to terminal "4" of the NRS valve connector. The sensor supply is output short circuit protected. A short circuit to the battery will not damage the circuit inside the ECM. The signal voltage from terminal "5" of the engine intake throttle valve and from terminal "2" of the NRS valve is supplied to the appropriate terminal at the P2/J2 ECM connector.

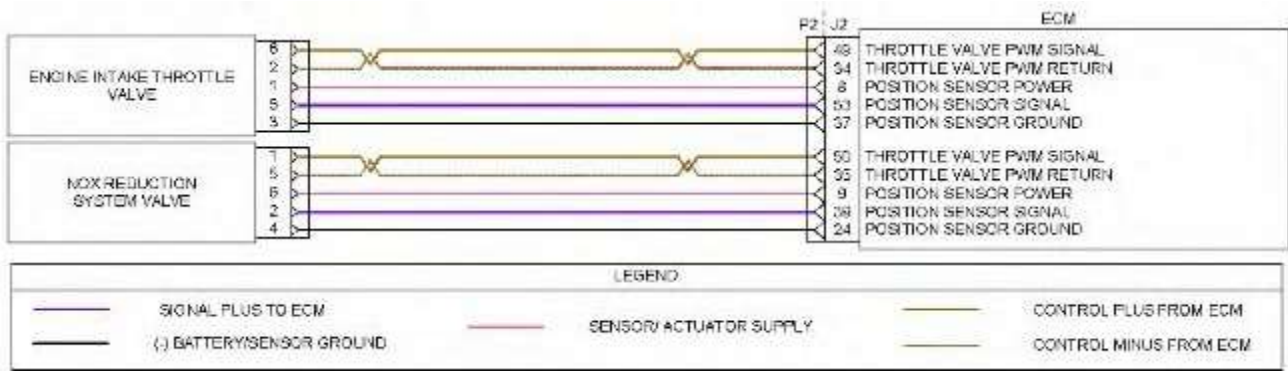

Illustration 1

g03636782

Schematic diagram for the valve position sensors

Not all connectors are shown. Refer to the appropriate Electrical Schematic.

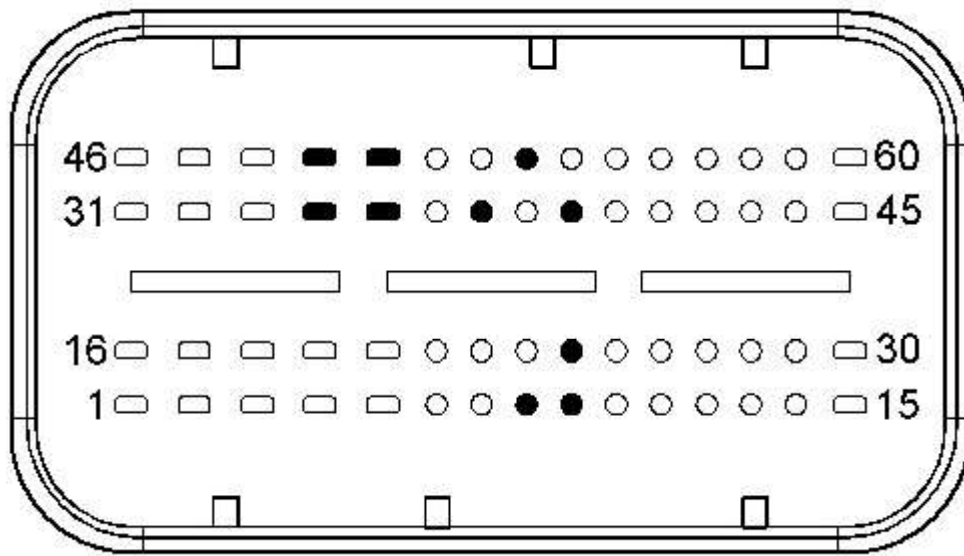

Illustration 2

g03616849

Typical view of the pin locations on the J2 connector for the valve position sensors.

- (8) Intake throttle valve position sensor 5 VDC supply
- (9) NRS valve position sensor 5 VDC supply
- (24) NRS valve position sensor ground
- (34) Intake throttle valve return
- (35) NRS valve return
- (37) Intake throttle valve position sensor ground
- (39) NRS valve position sensor signal
- (49) Intake throttle valve PWM signal
- (50) NRS valve PWM signal
- (53) Engine intake throttle valve position sensor signal

Table 2

--	--

Troubleshooting Test Steps	Values	Results
<p>1. Verify All Active and Recently Logged Diagnostic Codes</p> <p>A. Turn the keyswitch to the ON position. Wait at least 10 seconds for activation of the diagnostic codes.</p> <p>B. Verify if any of the diagnostic codes that are listed in Table 1 are active or recently logged.</p>	Diagnostic codes	<p>Result: None of the preceding diagnostic codes are active or recently logged.</p> <p>The fault may be intermittent. Refer to Troubleshooting, "Electrical Connectors - Inspect" in order to identify intermittent faults.</p> <p>Result: One or more of the preceding diagnostic codes are active or recently logged.</p> <p>Proceed to Test Step 2.</p>
<p>2. Inspect Electrical Connectors And Wiring</p> <p>A. Thoroughly inspect the terminal connections on the P2/J2 ECM connectors.</p> <p>B. Thoroughly inspect the connectors for the valves.</p> <p>C. Refer to Troubleshooting, "Electrical Connectors - Inspect".</p> <p>D. Perform a 30 N (6.7 lb) pull test on each of the wires in the ECM connector and the valve connectors that are associated with the active diagnostic code.</p> <p>E. Check the harness for abrasions and for pinch points from the valves back to the ECM.</p>	Damaged wire or connector	<p>Result: A damaged wire or damaged connector was found.</p> <p>Repair the damaged wire or the damaged connector.</p> <p>Use the electronic service tool to clear all logged diagnostic codes. Verify that the repair eliminates the fault.</p> <p>Result: All connectors, pins, and sockets are correctly connected and/or inserted and the harness is free of corrosion, of abrasion or of pinch points.</p> <p>Proceed to Test Step 3.</p>
<p>3. Measure the Sensor Supply Voltage at the Valve Connector</p> <p>A. Turn the keyswitch to the OFF position.</p> <p>B. Disconnect the suspect valve from the engine harness.</p> <p>C. Turn the keyswitch to the ON position.</p>	4.9 v to 5.1 V	<p>Result: The measured voltage is not within the expected range.</p> <p>The fault is in the wiring between the suspect valve and the ECM P2 connector.</p> <p>Check all wiring between the suspect valve and the ECM. Refer to the appropriate Electrical Schematic.</p>

<p>D. Measure the voltage at the harness connector for the valve from the 5 VDC supply terminal of the position sensor to the sensor ground terminal.</p>		<p>Replace the suspect wiring. Use the electronic service tool to clear all logged diagnostic codes and verify that the repair eliminates the fault.</p> <p>Result: The measured voltage is within the expected range.</p> <p>Proceed to Test Step 4.</p>
<p>4. Verify the Type of Active Diagnostic Code</p> <p>A. Turn the keyswitch to the ON position. Wait at least 10 seconds for activation of the diagnostic codes.</p> <p>B. Use the electronic service tool to check for active diagnostic codes. Record all active diagnostic codes.</p>	<p>Diagnostic codes</p>	<p>Result: An XX-4 diagnostic code is active at this time.</p> <p>Proceed to Test Step 5.</p> <p>Result: An XX-3 diagnostic code is active at this time.</p> <p>Proceed to Test Step 7.</p>
<p>5. Create an Open Circuit at the Valve Connector</p> <p>A. Turn the keyswitch to the OFF position.</p> <p>B. Disconnect the connector for the valve with the XX-4 diagnostic code.</p> <p>C. Turn the keyswitch to the ON position. Wait for at least 10 seconds for activation of the diagnostic codes.</p> <p>D. Use the electronic service tool to check the "Active Diagnostic Code" screen. Check for an XX-3 diagnostic code.</p> <p>Note: Diagnostic codes for all of the engine sensors will be active with the P2 connector disconnected. Ignore all other codes and only look for codes that relate to the suspect valve.</p> <p>E. Turn the keyswitch to the OFF position.</p>	<p>Diagnostic codes</p>	<p>Result: An XX-3 diagnostic code is active with the valve disconnected.</p> <p>Reconnect the connector for the valve. If the XX-4 diagnostic code returns, there is a short in the valve. Install a replacement valve. Refer to Disassembly and Assembly for the correct procedure. If the NRS valve is replaced, use the electronic service tool to perform the "EGR Valve Learn Reset". Use the electronic service tool to clear all logged diagnostic codes and verify that the repair eliminates the fault.</p> <p>Result: There is still an XX-4 diagnostic code active with the valve disconnected.</p> <p>Proceed to Test Step 6.</p>

<p>6. Create an Open Circuit at the ECM Connector</p> <p>A. Turn the keyswitch to the OFF position.</p> <p>B. Disconnect the P2 connector from the ECM.</p> <p>C. Turn the keyswitch to the ON position. Wait at least 10 seconds for activation of the diagnostic codes.</p> <p>D. Use the electronic service tool in order to monitor the "Active Diagnostic Code" screen. Check for an XX-3 diagnostic code for the suspect sensor. Note: Diagnostic codes for all of the engine sensors will be active with the P2 connector disconnected. Ignore all other codes and only look for codes that relate to the suspect sensor.</p>	<p>Diagnostic Codes</p>	<p>Result: An XX-3 diagnostic code is active with the P2 connector disconnected.</p> <p>The fault is in the wiring for the suspect sensor between the suspect valve connector and the P2 connector. Check all wiring between the suspect valve and the ECM. Refer to the appropriate Electrical Schematic. Replace the faulty wiring. Use the electronic service tool in order to clear all logged diagnostic codes and then verify that the repair eliminates the fault.</p> <p>Result: An XX-4 diagnostic code is still active with the P2 connector disconnected.</p> <p>Proceed to Test Step 9.</p>
<p>7. Create a Short Circuit at the Valve Connector</p> <p>A. Turn the keyswitch to the OFF position.</p> <p>B. Disconnect the connector for the valve with the XX-3 diagnostic code.</p> <p>C. Fabricate a jumper wire that is 150 mm (6 inch) long.</p> <p>D. Insert one end of the jumper wire into the terminal for the valve position sensor signal on the harness connector for the suspect valve. Insert the other end of the jumper into the terminal for the sensor ground on the harness connector for the suspect valve.</p> <p>E. Turn the keyswitch to the ON position. Wait at least 10 seconds for activation of the diagnostic codes.</p> <p>F. Access the "Active Diagnostic Codes" screen on the electronic service tool and check for an active</p>	<p>Diagnostic codes</p>	<p>Result: An XX-4 diagnostic code is active when the jumper is installed.</p> <p>Reconnect the connector for the suspect valve. Turn the keyswitch to the ON position. Use the electronic service tool to check for active diagnostic codes. If the XX-3 diagnostic code returns, there is an open circuit in the valve. Install a replacement valve. Refer to Disassembly and Assembly for the correct procedure. If the NRS valve is replaced, use the electronic service tool to perform the "EGR Valve Learn Reset". Use the electronic service tool to clear all logged diagnostic codes and verify that the repair eliminates the fault.</p>

<p>XX-4 diagnostic code for the suspect sensor.</p> <p>G. Remove the jumper.</p>		<p>Result: An XX-3 diagnostic code remains active when the jumper is installed.</p> <p>Proceed to Test Step 8.</p>
<p>8. Create a Short Circuit at the ECM Connector</p> <p>A. Turn the keyswitch to the OFF position.</p> <p>B. Disconnect the P2 connector from the ECM.</p> <p>C. Fabricate a jumper wire that is 150 mm (6 inch) long. Install the jumper between the suspect sensor signal pin and the sensor ground pin on the J2 connector.</p> <p>D. Turn the keyswitch to the ON position. Do not attempt to start the engine. Wait at least 10 seconds for activation of the diagnostic codes.</p> <p>E. Use the electronic service tool to check for an active XX-4 diagnostic code for the suspect sensor. Note: Diagnostic codes for all of the engine sensors will be active with the P2 connector disconnected. Ignore all other codes and only look for codes that relate to the suspect sensor.</p> <p>F. Turn the keyswitch to the OFF position. Remove the jumper wire.</p>	<p>Diagnostic codes</p>	<p>Result: An XX-4 diagnostic code is active with the jumper wire installed.</p> <p>The fault is in the wiring for the suspect sensor between the suspect valve connector and the P2 connector.</p> <p>Check all wiring between the suspect valve and the ECM. Refer to the appropriate Electrical Schematic.</p> <p>Replace the faulty wiring.</p> <p>Use the electronic service tool to clear all logged diagnostic codes and verify that the repair eliminates the fault.</p> <p>Result: The XX-3 diagnostic code is still active with the jumper wire installed.</p> <p>Proceed to Test Step 9.</p>
<p>9. Check if a Replacement ECM Eliminates the Fault</p> <p>A. Contact the Dealer Solution Network (DSN).</p> <p>B. If the DSN recommends the use of a replacement ECM, install a replacement ECM. Refer to Troubleshooting, "Replacing the ECM".</p> <p>C. Use the electronic service tool to recheck the system for active diagnostic codes.</p> <p>Cat C3.4B Engine Parts www.CATC34B.COM www.FPTIndustrialEngineParts.com</p>	<p>Diagnostic codes</p>	<p>Result: There are no active diagnostic codes with the replacement ECM.</p> <p>Reconnect the suspect ECM. If the fault returns with the suspect ECM, replace the ECM.</p> <p>Use the electronic service tool in order to clear all logged diagnostic codes and then verify that the repair eliminates the fault.</p> <p>Result: The diagnostic code is still present with the replacement ECM.</p>

Contact the DSN.



Previous Screen



Troubleshooting

C3.4B Engines

Media Number -UENR0611-10

Publication Date -01/02/2015

i06233870

Water in Fuel - Test

SMCS - 1263-038-NS; 1439-038

For a 97-15 diagnostic code, refer to Troubleshooting, "Fuel Contains Water" before returning to this procedure.

Water-in-Fuel Sensor Operation

The Water In Fuel (WIF) sensor is a normally open sensor. During normal operation, there will be no signal sent from the WIF sensor to the ECM. If water is detected in the fuel, the sensor will send a signal to the ECM. If the signal remains constant for 60 seconds, a 97-15 diagnostic code will become active. This diagnostic code can also be caused by a short in the WIF sensor circuit.

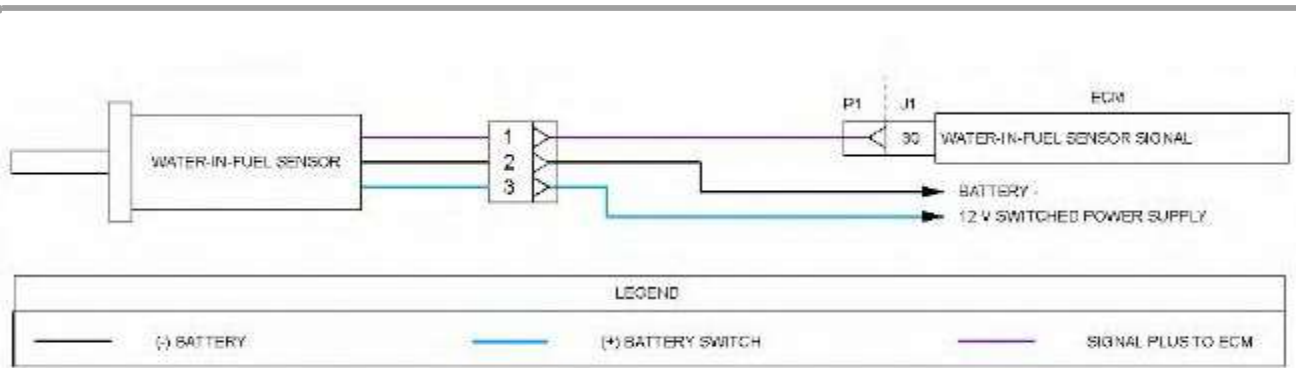

Illustration 1

g03636920

Schematic diagram for the WIF sensor circuit

Not all connectors are shown. Refer to the Electrical Schematic for the application.

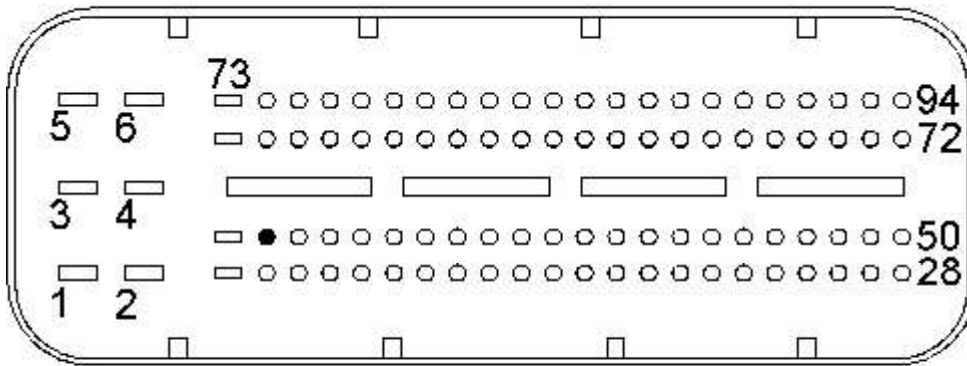

Illustration 2

g02734203

Typical view of the pin location on the P1 connector for the WIF sensor
 (30) WIF sensor signal

Table 1

Troubleshooting Test Steps	Values	Results
<p>1. Inspect Electrical Connectors and Wiring</p> <p>A. Turn the keyswitch to the OFF position.</p> <p>B. Thoroughly inspect the connector for the WIF sensor and the P1/J1 ECM connector. Refer to Troubleshooting, "Electrical Connectors - Inspect".</p> <p>C. Perform a 30 N (10 lb) pull test on each of the wires that are associated with the WIF sensor.</p> <p>D. Check the harness for abrasions, for pinch points, and for corrosion.</p>	<p>Damaged wire or connector</p>	<p>Result: A damaged wire or damaged connector was found.</p> <p>Repair: Repair the damaged wire or the damaged connector. Use the electronic service tool to clear all logged diagnostic codes. Verify that the repair eliminates the fault.</p> <p>Result: All connectors, pins, and sockets are correctly connected and/or inserted and the harness is free of corrosion, of abrasion or of pinch points.</p> <p>Proceed to Test Step 2.</p>
<p>2. Check for Active Diagnostic Codes</p> <p>A. Connect the electronic service tool to the diagnostic connector.</p>	<p>Diagnostic codes</p>	<p>Result: A 97-15 diagnostic code is active.</p> <p>Repair: Ensure that there is no water present in the fuel before continuing with</p>

<p>B. Turn the keyswitch to the ON position.</p> <p>C. Wait for at least 1 minute.</p> <p>D. Monitor the active diagnostic code screen on the electronic service tool. Check and record any active diagnostic codes.</p>		<p>this procedure. Refer to Troubleshooting, "Fuel Contains Water". Proceed to Test Step 3.</p> <p>Result: A 97-15 diagnostic code is not active at this time. If the WIF sensor is not operating correctly, proceed to Test Step 5.</p>
<p>3. Disconnect the WIF Sensor</p> <p>A. Turn the keyswitch to the OFF position.</p> <p>B. Disconnect the WIF sensor from the harness.</p> <p>C. Turn the keyswitch to the ON position. Wait for at least 1 minute.</p> <p>D. Use the electronic service tool to check for an active 97-15 diagnostic code.</p>	<p>Diagnostic codes</p>	<p>Result: The code disappears with the sensor disconnected.</p> <p>Repair: Replace the WIF sensor. Use the electronic service tool to clear all logged diagnostic codes and verify that the repair eliminates the fault.</p> <p>Result: A 97-15 diagnostic code is still active with the sensor disconnected.</p> <p>Reconnect the sensor and proceed to Test Step 4.</p>
<p>4. Check the Sensor Signal Wire for a Short Circuit</p> <p>A. Turn the keyswitch to the OFF position.</p> <p>B. Disconnect the WIF sensor connector. Disconnect the P1 connector from the ECM.</p> <p>C. Use a suitable multimeter to check the resistance between P1:30 and all other terminals on the P1 connector.</p>	<p>Greater than 1 k Ohm</p>	<p>Result: At least one of the resistance measurements is less than 1 k Ohm. The fault is in the wiring between the WIF sensor and the P1 ECM connector.</p> <p>Repair: Check all wiring between the WIF sensor and the ECM. Refer to the Electrical Schematic for the application. Replace the faulty wiring. Use the electronic service tool to clear all logged diagnostic codes and verify that the repair eliminates the fault.</p> <p>Result: Each resistance measurement is greater than 1 k Ohm.</p> <p>Contact the Dealer Solution Network (DSN).</p>
<p>5. Check that the Sensor is Receiving the Correct Voltage</p>	<p>Greater than 11 V</p>	<p>Result: The measured voltage is less than 11 V.</p>

<p>A. Turn the keyswitch to the OFF position.</p> <p>B. Disconnect the WIF sensor from the harness.</p> <p>C. Turn the keyswitch to the ON position.</p> <p>D. Measure the voltage between terminal 3 on the harness connector for the WIF sensor and a suitable ground.</p> <p>E. Turn the keyswitch to the OFF position.</p>		<p>The fault is in the switched battery supply wiring to pin 3 on the WIF sensor connector.</p> <p>Repair: Check all battery supply wiring to the WIF sensor. Refer to the Electrical Schematic for the application. Replace the faulty wiring. Use the electronic service tool to clear all logged diagnostic codes and verify that the repair eliminates the fault.</p> <p>Result: The measured voltage is at least 11 V.</p> <p>Proceed to Test Step 6.</p>
<p>6. Check the WIF sensor Ground Wire</p> <p>A. Turn the keyswitch to the OFF position.</p> <p>B. Disconnect the WIF sensor from the harness.</p> <p>C. Turn the keyswitch to the ON position.</p> <p>D. Measure the voltage between terminal 2 and terminal 3 on the harness connector for the WIF sensor.</p>	<p>Greater than 11 V</p>	<p>Result: The measured voltage is less than 11 V. The fault is the wiring between terminal 2 on the WIF sensor connector and battery negative.</p> <p>Repair: Check all wiring between the WIF sensor and battery negative. Replace the faulty wiring. Use the electronic service tool to clear all logged diagnostic codes and verify that the repair eliminates the fault.</p> <p>Result: The measured voltage is at least 11 V.</p> <p>Proceed to Test Step 7.</p>
<p>7. Create a Short Circuit at the WIF Sensor Connector</p> <p>A. Turn the keyswitch to the OFF position.</p> <p>B. Disconnect the WIF sensor from the harness.</p> <p>C. Fabricate a jumper and install the jumper wire between terminal 1 and terminal 2 on the harness connector for the WIF sensor.</p>	<p>Diagnostic codes</p>	<p>Result: A 97-15 diagnostic code is active with the jumper installed.</p> <p>Repair: Replace the WIF sensor. Use the electronic service tool to clear all logged diagnostic codes and verify that the repair eliminates the fault.</p> <p>Result: A 97-15 diagnostic code is not active with the jumper installed.</p>

<p>D. Turn the keyswitch to the ON position. Wait for at least 1 minute.</p> <p>E. Use the electronic service tool to check for an active 97-15 diagnostic code.</p> <p>F. Turn the keyswitch to the OFF position.</p> <p>G. Remove the jumper.</p>		<p>Proceed to Test Step 8.</p>
<p>8. Check the Sensor Signal Wire for an Open Circuit</p> <p>A. Turn the keyswitch to the OFF position.</p> <p>B. Disconnect the WIF sensor. Disconnect the P1 connector from the ECM.</p> <p>C. Use a suitable multimeter to measure the resistance between terminal 1 on the harness connector for the WIF sensor and P1:30.</p>	<p>Less than 5 Ohms</p>	<p>Result: The measured resistance is greater than 5 Ohms. The fault is in the wiring between the WIF sensor and the P1 connector.</p> <p>Repair: Check all wiring between the WIF sensor and the ECM. Refer to the Electrical Schematic for the application.</p> <p>Repair: Replace the faulty wiring. Use the electronic service tool to clear all logged diagnostic codes and verify that the repair eliminates the fault.</p> <p>Result: The measured resistance is less than 5 Ohms.</p> <p>Contact the DSN.</p>

CAT C3.4B Engine Parts
Contact phone: 269 673 1638
Email: EngineParts@HeavyEquipmentRestorationParts.com
Alternate email: engineparts2@gmail.com
Website: www.CATC34B.com
Related website: www.HeavyEquipmentRestorationParts.com
www.FPTIndustrialEngineParts.com



Troubleshooting

C3.4B Engines

Media Number -UENR0611-10

Publication Date -01/02/2015

i05980253

Welding Precaution

SMCS - 1000

Correct welding procedures are necessary in order to avoid damage to the Electronic Control Module (ECM) , to sensors, and to associated components. Components for the driven equipment should also be considered. When possible, remove the component that requires welding. When welding on an application that is equipped with an electronically controlled engine and removal of the component is not possible, the following procedure must be followed. This procedure minimizes the risk to the electronic components.

1. Stop the engine. Remove the electrical power from the ECM.
2. Ensure that the fuel supply to the engine is turned off.
3. Disconnect the negative battery cable from the battery. If a battery disconnect switch is installed, open the switch.
4. Disconnect all electronic components from the wiring harnesses. Include the following components:
 - Electronic components for the driven equipment
 - ECM
 - Sensors
 - Electronically controlled valves
 - Relays
 - Electronic control units

NOTICE

Do not use electrical components (ECM or ECM sensors) or electronic component grounding points for grounding the welder.

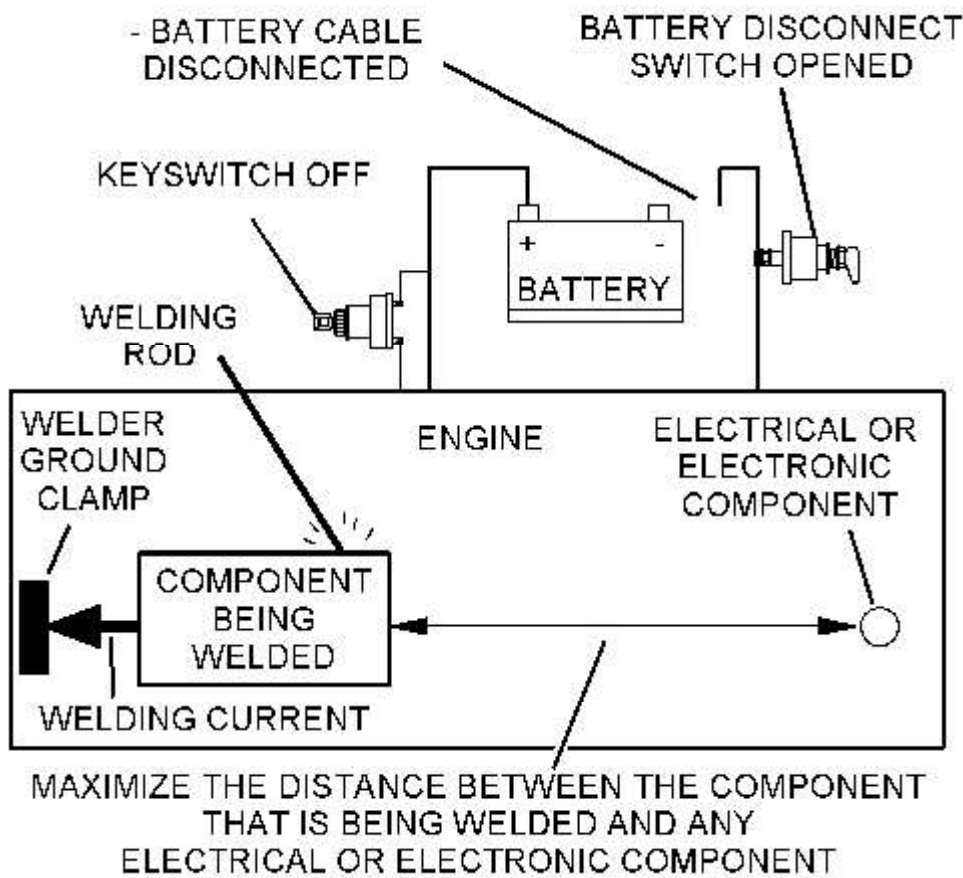

Illustration 1

g01143634

Service welding guide (typical diagram)

5. When possible, connect the ground clamp for the welding equipment directly to the engine component that will be welded. Place the clamp as close as possible to the weld. Close positioning reduces the risk of welding current damage to the engine bearings, to the electrical components, and to other components.
 6. Protect the wiring harnesses from welding debris and/or from welding spatter.
 7. Use standard welding procedures to weld the materials together.
-

CAT C3.4B Engine Parts

Contact phone: 269 673 1638

Email: EngineParts@HeavyEquipmentRestorationParts.com

Alternate email: engineparts2@gmail.com

Website: www.CATC34B.com

Related website: www.HeavyEquipmentRestorationParts.com

www.FPTIndustrialEngineParts.com