



Operation and Maintenance Manual

C3.4B Industrial Engine

CJG 1-UP (Engine)
CJ3 1-UP (Package)

Important Safety Information

Most accidents that involve product operation, maintenance and repair are caused by failure to observe basic safety rules or precautions. An accident can often be avoided by recognizing potentially hazardous situations before an accident occurs. A person must be alert to potential hazards, including human factors that can affect safety. This person should also have the necessary training, skills and tools to perform these functions properly.

Improper operation, lubrication, maintenance or repair of this product can be dangerous and could result in injury or death.

Do not operate or perform any lubrication, maintenance or repair on this product, until you verify that you are authorized to perform this work, and have read and understood the operation, lubrication, maintenance and repair information.

Safety precautions and warnings are provided in this manual and on the product. If these hazard warnings are not heeded, bodily injury or death could occur to you or to other persons.

The hazards are identified by the "Safety Alert Symbol" and followed by a "Signal Word" such as "DANGER", "WARNING" or "CAUTION". The Safety Alert "WARNING" label is shown below.



The meaning of this safety alert symbol is as follows:

Attention! Become Alert! Your Safety is Involved.

The message that appears under the warning explains the hazard and can be either written or pictorially presented.

A non-exhaustive list of operations that may cause product damage are identified by "NOTICE" labels on the product and in this publication.

Caterpillar cannot anticipate every possible circumstance that might involve a potential hazard. The warnings in this publication and on the product are, therefore, not all inclusive. You must not use this product in any manner different from that considered by this manual without first satisfying yourself that you have considered all safety rules and precautions applicable to the operation of the product in the location of use, including site-specific rules and precautions applicable to the worksite. If a tool, procedure, work method or operating technique that is not specifically recommended by Caterpillar is used, you must satisfy yourself that it is safe for you and for others. You should also ensure that you are authorized to perform this work, and that the product will not be damaged or become unsafe by the operation, lubrication, maintenance or repair procedures that you intend to use.

The information, specifications, and illustrations in this publication are on the basis of information that was available at the time that the publication was written. The specifications, torques, pressures, measurements, adjustments, illustrations, and other items can change at any time. These changes can affect the service that is given to the product. Obtain the complete and most current information before you start any job. Cat dealers have the most current information available.



When replacement parts are required for this product Caterpillar recommends using Cat replacement parts.

Failure to follow this warning may lead to premature failures, product damage, personal injury or death.

In the United States, the maintenance, replacement, or repair of the emission control devices and systems may be performed by any repair establishment or individual of the owner's choosing.

Table of Contents

Foreword	4
----------------	---

Safety Section

Safety Messages	5
-----------------------	---

General Hazard Information	6
----------------------------------	---

Burn Prevention	10
-----------------------	----

Fire Prevention and Explosion Prevention	11
--	----

Crushing Prevention and Cutting Prevention ..	13
---	----

Mounting and Dismounting	13
--------------------------------	----

High Pressure Fuel Lines	14
--------------------------------	----

Before Starting Engine	15
------------------------------	----

Engine Starting	15
-----------------------	----

Engine Stopping	16
-----------------------	----

Electrical System	16
-------------------------	----

Engine Electronics	17
--------------------------	----

Product Information Section

General Information	19
---------------------------	----

Product Identification Information	28
--	----

Operation Section

Lifting and Storage	32
---------------------------	----

Features and Controls	33
-----------------------------	----

Engine Diagnostics	48
--------------------------	----

Engine Starting	52
-----------------------	----

Engine Operation	55
------------------------	----

Cold Weather Operation	59
------------------------------	----

Engine Stopping	63
-----------------------	----

Maintenance Section

Refill Capacities	65
-------------------------	----

Maintenance Recommendations	70
-----------------------------------	----

Maintenance Interval Schedule	73
-------------------------------------	----

Warranty Section

Warranty Information	109
----------------------------	-----

Reference Information Section

Engine Ratings	110
----------------------	-----

Customer Service	111
------------------------	-----

Reference Materials	113
---------------------------	-----

Index Section

Index	116
-------------	-----

Foreword

Literature Information

This manual contains safety, operation instructions, lubrication and maintenance information. This manual should be stored in or near the engine area in a literature holder or literature storage area. Read, study and keep it with the literature and engine information.

English is the primary language for all Cat publications. The English used facilitates translation and consistency in electronic media delivery.

Some photographs or illustrations in this manual show details or attachments that may be different from your engine. Guards and covers may have been removed for illustrative purposes. Continuing improvement and advancement of product design may have caused changes to your engine which are not included in this manual. Whenever a question arises regarding your engine, or this manual, please consult with your Cat dealer for the latest available information.

Safety

This safety section lists basic safety precautions. In addition, this section identifies hazardous, warning situations. Read and understand the basic precautions listed in the safety section before operating or performing lubrication, maintenance and repair on this product.

Operation

Operating techniques outlined in this manual are basic. They assist with developing the skills and techniques required to operate the engine more efficiently and economically. Skill and techniques develop as the operator gains knowledge of the engine and its capabilities.

The operation section is a reference for operators. Photographs and illustrations guide the operator through procedures of inspecting, starting, operating and stopping the engine. This section also includes a discussion of electronic diagnostic information.

Maintenance

The maintenance section is a guide to engine care. The illustrated, step-by-step instructions are grouped by fuel consumption, service hours and/or calendar time maintenance intervals. Items in the maintenance schedule are referenced to detailed instructions that follow.

Use fuel consumption or service hours to determine intervals. Calendar intervals shown (daily, annually, etc.) may be used instead of service meter intervals if they provide more convenient schedules and approximate the indicated service meter reading.

Recommended service should be performed at the appropriate intervals as indicated in the Maintenance Interval Schedule. The actual operating environment of the engine also governs the Maintenance Interval Schedule. Therefore, under extremely severe, dusty, wet or freezing cold operating conditions, more frequent lubrication and maintenance than is specified in the Maintenance Interval Schedule may be necessary.

The maintenance schedule items are organized for a preventive maintenance management program. If the preventive maintenance program is followed, a periodic tune-up is not required. The implementation of a preventive maintenance management program should minimize operating costs through cost avoidances resulting from reductions in unscheduled downtime and failures.

Maintenance Intervals

Perform maintenance on items at multiples of the original requirement. Each level and/or individual items in each level should be shifted ahead or back depending upon your specific maintenance practices, operation and application. We recommend that the maintenance schedules be reproduced and displayed near the engine as a convenient reminder. We also recommend that a maintenance record be maintained as part of the engine's permanent record.

See the section in the Operation and Maintenance Manual, "Maintenance Records" for information regarding documents that are generally accepted as proof of maintenance or repair. Your authorized Cat dealer can assist you in adjusting your maintenance schedule to meet the needs of your operating environment.

Overhaul

Major engine overhaul details are not covered in the Operation and Maintenance Manual except for the interval and the maintenance items in that interval. Major repairs are best left to trained personnel or an authorized Cat dealer. Your Cat dealer offers a variety of options regarding overhaul programs. If you experience a major engine failure, there are also numerous after failure overhaul options available from your Cat dealer. Consult with your dealer for information regarding these options.

California Proposition 65 Warning

Diesel engine exhaust and some of its constituents are known to the State of California to cause cancer, birth defects, and other reproductive harm.

Battery posts, terminals and related accessories contain lead and lead compounds. **Wash hands after handling.**

Safety Section

i05325428

Safety Messages

SMCS Code: 1000; 7405

There may be several specific warning signs on your engine. The exact location and a description of the warning signs are reviewed in this section. Ensure that you become familiar with all warning signs.

Ensure that all of the warning signs are legible. Clean the warning signs or replace the warning signs if the words cannot be read or if the illustrations are not visible. Use a cloth, water, and soap to clean the warning signs. Do not use solvents, gasoline, or other harsh chemicals. Solvents, gasoline, or harsh chemicals could loosen the adhesive that secures the warning signs. The warning signs that are loosened could drop off the engine.

Replace any warning sign that is damaged or missing. If a warning sign is attached to a part of the engine that is replaced, install a new warning sign on the replacement part. Your Cat dealer can provide new warning signs.

Universal Warning

 **WARNING**

Do not operate or work on this equipment unless you have read and understand the instructions and warnings in the Operation and Maintenance Manuals. Failure to follow the instructions or heed the warnings could result in serious injury or death.

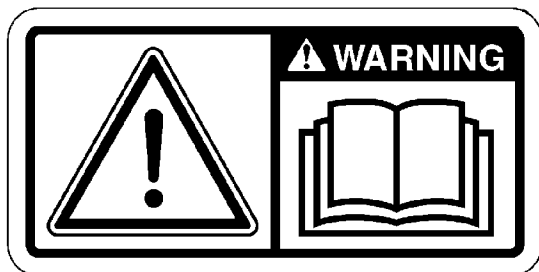

Illustration 1

g01154807

Typical example

The Universal Warning label (1) is located on the top of the engine, on the engine interface connector cover.

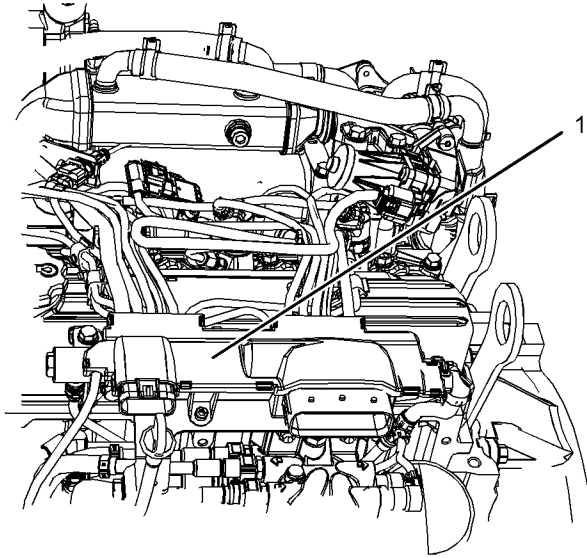

Illustration 2

Typical example

g03373747

i06708180

General Hazard Information

SMCS Code: 1000; 4450; 7405

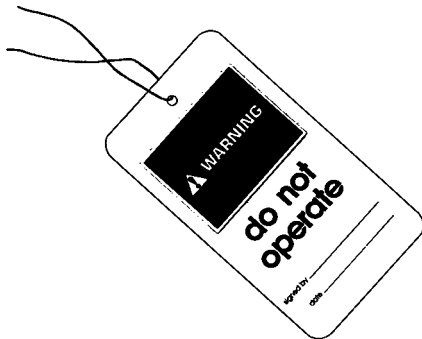

Illustration 3

g00104545

Attach a “Do Not Operate” warning tag or a similar warning tag to the start switch or to the controls before the engine is serviced or before the engine is repaired. These warning tags (Special Instruction, SEHS7332) are available from your Cat dealer. Attach the warning tags to the engine and to each operator control station. When appropriate, disconnect the starting controls.

Do not allow unauthorized personnel on the engine, or around the engine when the engine is being serviced.

- Tampering with the engine installation or tampering with the OEM supplied wiring can be dangerous. Personal injury, death and/or engine damage could result.
- Vent the engine exhaust to the outside when the engine is operated in an enclosed area.
- If the engine is not running, do not release the secondary brake or the parking brake systems unless the vehicle is blocked or unless the vehicle is restrained.
- Wear a hard hat, protective glasses, and other protective equipment, as required.
- When work is performed around an engine that is operating, wear protective devices for ears to help prevent damage to hearing.
- Do not wear loose clothing or jewelry that can snag on controls or on other parts of the engine.
- Ensure that all protective guards and all covers are secured in place on the engine.
- Never put maintenance fluids into glass containers. Glass containers can break.
- Use all cleaning solutions with care.
- Report all necessary repairs.

Unless other instructions are provided, perform the maintenance under the following conditions:

- The engine is stopped. Ensure that the engine cannot be started.

- The protective locks or the controls are in the applied position.
- Engage the secondary brakes or parking brakes.
- Block the vehicle or restrain the vehicle before maintenance or repairs are performed.
- Disconnect the batteries when maintenance is performed or when the electrical system is serviced. Disconnect the battery ground leads. Tape the leads to help prevent sparks. If equipped, allow the diesel exhaust fluid to be purged before disconnecting the battery.
- If equipped, disconnect the connectors for the unit injectors that are on the valve cover base. This action will help prevent personal injury from the high voltage to the unit injectors. Do not come in contact with the unit injector terminals while the engine is operating.
- Do not attempt any repairs or any adjustments to the engine while the engine is operating.
- Do not attempt any repairs that are not understood. Use the proper tools. Replace any equipment that is damaged or repair the equipment.
- For initial start-up of a new engine or for starting an engine that has been serviced, make provisions to stop the engine if an overspeed occurs. The stopping of the engine may be accomplished by shutting off the fuel supply and/or the air supply to the engine. Ensure that only the fuel supply line is shut off. Ensure that the fuel return line is open.
- Start the engine from the operators station (cab). Never short across the starting motor terminals or the batteries. This action could bypass the engine neutral start system and/or the electrical system could be damaged.

Engine exhaust contains products of combustion which may be harmful to your health. Always start the engine and operate the engine in a well ventilated area. If the engine is in an enclosed area, vent the engine exhaust to the outside.

Cautiously remove the following parts. To help prevent spraying or splashing of pressurized fluids, hold a rag over the part that is being removed.

- Filler caps
- Grease fittings
- Pressure taps
- Breathers
- Drain plugs

Use caution when cover plates are removed. Gradually loosen, but do not remove the last two bolts or nuts that are at opposite ends of the cover plate or the device. Before removing the last two bolts or nuts, pry the cover loose to relieve any spring pressure or other pressure.

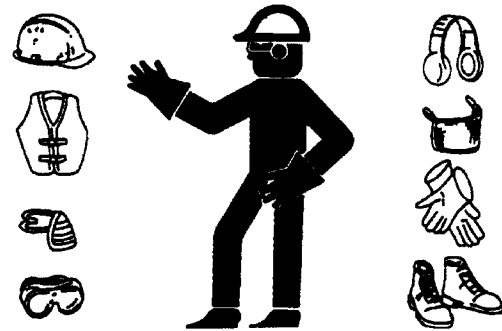

Illustration 4

g00702020

- Wear a hard hat, protective glasses, and other protective equipment, as required.
- When work is performed around an engine that is operating, wear protective devices for ears to help prevent damage to hearing.
- Do not wear loose clothing or jewelry that can snag on controls or on other parts of the engine.
- Ensure that all protective guards and all covers are secured in place on the engine.
- Never put maintenance fluids into glass containers. Glass containers can break.
- Use all cleaning solutions with care.
- Report all necessary repairs.

Unless other instructions are provided, perform the maintenance under the following conditions:

- The engine is stopped. Ensure that the engine cannot be started.
- Disconnect the batteries when maintenance is performed or when the electrical system is serviced. Disconnect the battery ground leads. Tape the leads to help prevent sparks.
- Do not attempt any repairs that are not understood. Use the proper tools. Replace any equipment that is damaged or repair the equipment.

Pressurized Air and Water

Pressurized air and/or water can cause debris and/or hot water to be blown out. This action could result in personal injury.

When pressurized air and/or pressurized water is used for cleaning, wear protective clothing, protective shoes, and eye protection. Eye protection includes goggles or a protective face shield.

The maximum air pressure for cleaning purposes must be below 205 kPa (30 psi). The maximum water pressure for cleaning purposes must be below 275 kPa (40 psi).

Fluid Penetration

Pressure can be trapped in the hydraulic circuit long after the engine has been stopped. The pressure can cause hydraulic fluid or items such as pipe plugs to escape rapidly if the pressure is not relieved correctly.

Do not remove any hydraulic components or parts until pressure has been relieved or personal injury may occur. Do not disassemble any hydraulic components or parts until pressure has been relieved or personal injury may occur. Refer to the OEM information for any procedures that are required to relieve the hydraulic pressure.

Refer to Special Publication, NENG2500, “Cat Dealer Service Tool Catalog” for tools and supplies suitable to collect and contain fluids on Cat products.

Dispose of all fluids according to local regulations and mandates.

Static Electricity Hazard when Fueling with Ultra-low Sulfur Diesel Fuel

The removal of sulfur and other compounds in ultra-low sulfur diesel fuel (ULSD fuel) decreases the conductivity of ULSD and increases the ability of ULSD to store static charge. Refineries may have treated the fuel with a static dissipating additive. Many factors can reduce the effectiveness of the additive over time. Static charges can build up in ULSD fuel while the fuel is flowing through fuel delivery systems. Static electricity discharge when combustible vapors are present could result in a fire or explosion. Ensure that the entire system used to refuel your machine (fuel supply tank, transfer pump, transfer hose, nozzle, and others) is properly grounded and bonded. Consult with your fuel or fuel system supplier to ensure that the delivery system complies with fueling standards for proper grounding and bonding.

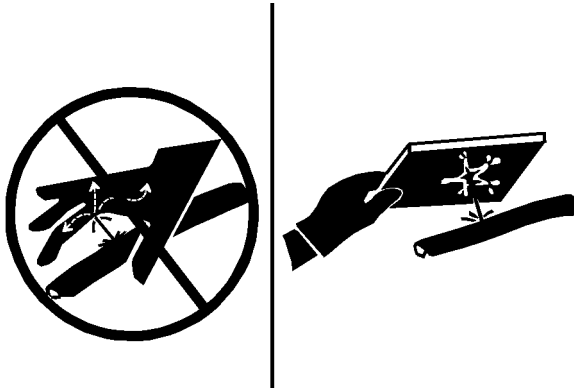

Illustration 5

g00687600

Always use a board or cardboard when you check for a leak. Leaking fluid that is under pressure can penetrate body tissue. Fluid penetration can cause serious injury and possible death. A pin hole leak can cause severe injury. If fluid is injected into your skin, you must get treatment immediately. Seek treatment from a doctor that is familiar with this type of injury.

Containing Fluid Spillage

Care must be taken to ensure that fluids are contained during performance of inspection, maintenance, testing, adjusting, and repair of the product. Be prepared to collect the fluid with suitable containers before opening any compartment or disassembling any component containing fluids.

⚠ WARNING

Avoid static electricity risk when fueling. Ultra-low sulfur diesel fuel (ULSD fuel) poses a greater static ignition hazard than earlier diesel formulations with a higher sulfur contents. Avoid death or serious injury from fire or explosion. Consult with your fuel or fuel system supplier to ensure the delivery system is in compliance with fueling standards for proper grounding and bonding practices.

Inhalation

Illustration 6

g00702022

Exhaust

Use caution. Exhaust fumes can be hazardous to health. If you operate the equipment in an enclosed area, adequate ventilation is necessary.

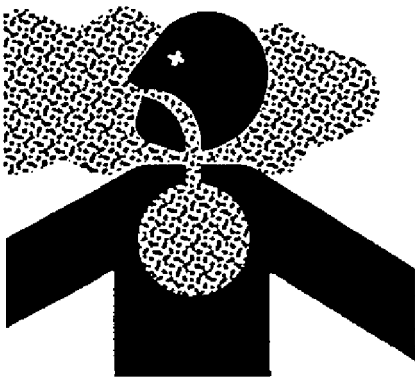
Asbestos Information

Cat equipment and replacement parts that are shipped from Caterpillar are asbestos free. Caterpillar recommends the use of only genuine Cat replacement parts. Use the following guidelines when you handle any replacement parts that contain asbestos or when you handle asbestos debris.

Use caution. Avoid inhaling dust that might be generated when you handle components that contain asbestos fibers. Inhaling this dust can be hazardous to your health. The components that may contain asbestos fibers are brake pads, brake bands, lining material, clutch plates, and some gaskets. The asbestos that is used in these components is usually bound in a resin or sealed in some way. Normal handling is not hazardous unless airborne dust that contains asbestos is generated.

If dust that may contain asbestos is present, there are several guidelines that should be followed:

- Never use compressed air for cleaning.

- Avoid brushing materials that contain asbestos.
- Avoid grinding materials that contain asbestos.
- Use a wet method to clean up asbestos materials.
- A vacuum cleaner that is equipped with a high efficiency particulate air filter (HEPA) can also be used.
- Use exhaust ventilation on permanent machining jobs.
- Wear an approved respirator if there is no other way to control the dust.
- Comply with applicable rules and regulations for the work place. In the United States, use Occupational Safety and Health Administration (OSHA) requirements. These OSHA requirements can be found in "29 CFR 1910.1001".
- Obey environmental regulations for the disposal of asbestos.
- Stay away from areas that might have asbestos particles in the air.

Dispose of Waste Properly

Illustration 7

g00706404

Improperly disposing of waste can threaten the environment. Potentially harmful fluids should be disposed of according to local regulations.

Always use leakproof containers when you drain fluids. Do not pour waste onto the ground, down a drain, or into any source of water.

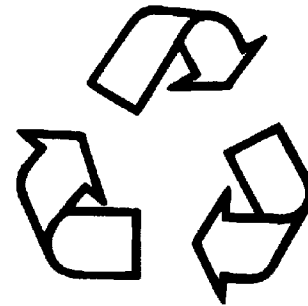
i06702818

Burn Prevention

SMCS Code: 1000; 4450; 7405

Do not touch any part of an operating engine system. The engine, the exhaust, and the engine aftertreatment system can reach temperatures as high as 650 °C (1202 °F) under normal operating conditions.

At idle engine speed and/or zero vehicle speed, an operator can request manual regeneration. Under this condition, the exhaust gas temperature can reach 650 °C (1202 °F). Otherwise automatic regeneration can produce exhaust gas temperatures as high as 650 °C (1202 °F).

Allow the engine system to cool before any maintenance is performed. Relieve all pressure in the following systems, hydraulic system, lubrication system, fuel system, and the cooling system before related items are disconnected.

WARNING

Contact with high pressure fuel may cause fluid penetration and burn hazards. High pressure fuel spray may cause a fire hazard. Failure to follow these inspection, maintenance and service instructions may cause personal injury or death.

After the engine has stopped, you must wait for 10 minutes to allow the fuel pressure to be purged from the high-pressure fuel lines before any service or repair is performed on the engine fuel lines.

Induction System

WARNING

Sulfuric Acid Burn Hazard may cause serious personal injury or death.

The exhaust gas cooler may contain a small amount of sulfuric acid. The use of fuel with sulfur levels greater than 15 ppm may increase the amount of sulfuric acid formed. The sulfuric acid may spill from the cooler during service of the engine. The sulfuric acid will burn the eyes, skin and clothing on contact. Always wear the appropriate personal protective equipment (PPE) that is noted on a material safety data sheet (MSDS) for sulfuric acid. Always follow the directions for first aid that are noted on a material safety data sheet (MSDS) for sulfuric acid.

Coolant

When the engine is at operating temperature, the engine coolant is hot. The coolant is also under pressure. The radiator and all lines to the heaters or to the engine contain hot coolant.

Any contact with hot coolant or with steam can cause severe burns. Allow cooling system components to cool before the cooling system is drained.

Check the coolant level after the engine has stopped and the engine has been allowed to cool.

Ensure that the filler cap is cool before removing the filler cap. The filler cap must be cool enough to touch with a bare hand. Remove the filler cap slowly to relieve pressure.

Cooling system conditioner contains alkali. Alkali can cause personal injury. Do not allow alkali to contact the skin, the eyes, or the mouth.

i05784184

Oils

Skin may be irritated following repeated or prolonged exposure to mineral and synthetic base oils. Refer to your suppliers Material Safety Data Sheets for detailed information. Hot oil and lubricating components can cause personal injury. Do not allow hot oil to contact the skin. Appropriate personal protective equipment should be used.

Diesel Fuel

Diesel may be irritating to the eyes, respiratory system, and skin. Prolonged exposure to diesel may cause various skin conditions. Appropriate personal protective equipment should be used. Refer to supplier Material safety Data sheets for detailed information.

Aftertreatment System

Allow the aftertreatment to cool down before any maintenance or repair is performed.

Batteries

Electrolyte is an acid. Electrolyte can cause personal injury. Do not allow electrolyte to contact the skin or the eyes. Always wear protective glasses for servicing batteries. Wash hands after touching the batteries and connectors. Use of gloves is recommended.

Fire Prevention and Explosion Prevention

SMCS Code: 1000; 4450; 7405



Illustration 8

g00704000

All fuels, most lubricants, and some coolant mixtures are flammable.

Flammable fluids that are leaking or spilled onto hot surfaces or onto electrical components can cause a fire. Fire may cause personal injury and property damage.

A flash fire may result if the covers for the engine crankcase are removed within 15 minutes after an emergency shutdown.

Determine whether the engine will be operated in an environment that allows combustible gases to be drawn into the air inlet system. These gases could cause the engine to overspeed. Personal injury, property damage, or engine damage could result.

If the application involves the presence of combustible gases, consult your Cat dealer for additional information about suitable protection devices.

Remove all flammable materials such as fuel, oil, and debris from the engine. Do not allow any flammable materials to accumulate on the engine.

Store fuels and lubricants in properly marked containers away from unauthorized persons. Store oily rags and any flammable materials in protective containers. Do not smoke in areas that are used for storing flammable materials.

Do not expose the engine to any flame.

Exhaust shields (if equipped) protect hot exhaust components from oil or fuel spray in a line, a tube, or a seal failure. Exhaust shields must be installed correctly.

Safety Section
Fire Prevention and Explosion Prevention

Do not weld on lines or tanks that contain flammable fluids. Do not flame cut lines or tanks that contain flammable fluid. Clean any such lines or tanks thoroughly with a nonflammable solvent prior to welding or flame cutting.

Wiring must be kept in good condition. All electrical wires must be properly routed and securely attached. Check all electrical wires daily. Repair any wires that are loose or frayed before you operate the engine. Clean all electrical connections and tighten all electrical connections.

Eliminate all wiring that is unattached or unnecessary. Do not use any wires or cables that are smaller than the recommended gauge. Do not bypass any fuses and/or circuit breakers.

Arcing or sparking could cause a fire. Secure connections, recommended wiring, and properly maintained battery cables will help to prevent arcing or sparking.

WARNING

Contact with high pressure fuel may cause fluid penetration and burn hazards. High pressure fuel spray may cause a fire hazard. Failure to follow these inspection, maintenance and service instructions may cause personal injury or death.

After the engine has stopped, you must wait for 10 minutes in order to allow the fuel pressure to be purged from the high-pressure fuel lines before any service or repair is performed on the engine fuel lines. The 10 minute wait will also allow static charge to dissipate from the low-pressure fuel system.

Inspect all lines and hoses for wear or for deterioration. The hoses must be properly routed. The lines and hoses must have adequate support and secure clamps. Tighten all connections to the recommended torque. Leaks can cause fires.

Oil filters and fuel filters must be properly installed. The filter housings must be tightened to the proper torque.



Illustration 9

g00704059

Use caution when you are refueling an engine. Do not smoke while you are refueling an engine. Do not refuel an engine near open flames or sparks. Always stop the engine before refueling.



Illustration 10

g00704135

Gases from a battery can explode. Keep any open flames or sparks away from the top of a battery. Do not smoke in battery charging areas.

Never check the battery charge by placing a metal object across the terminal posts. Use a voltmeter or a hydrometer.

Improper jumper cable connections can cause an explosion that can result in injury. Refer to the Operation Section of this manual for specific instructions.

Do not charge a frozen battery. This action may cause an explosion.

The batteries must be kept clean. The covers (if equipped) must be kept on the cells. Use the recommended cables, connections, and battery box covers when the engine is operated.

Fire Extinguisher

Make sure that a fire extinguisher is available. Be familiar with the operation of the fire extinguisher. Inspect the fire extinguisher and service the fire extinguisher regularly. Obey the recommendations on the instruction plate.

Ether

Ether is flammable and poisonous.

Use ether in that are ventilated . Do not smoke while you are replacing an ether cylinder or while you are using an ether spray.

Do not store ether cylinders in living areas or in the engine compartment. Do not store ether cylinders in direct sunlight or in temperatures above 49 °C (120 °F). Keep ether cylinders away from open flames or sparks.

Dispose of used ether cylinders properly. Do not puncture an ether cylinder. Keep ether cylinders away from unauthorized personnel.

Do not spray ether into an engine if the engine is equipped with a thermal starting aid for cold weather starting.

Lines, Tubes, and Hoses

Do not bend high-pressure lines. Do not strike high-pressure lines. Do not install any lines that are bent or damaged.

Repair any lines that are loose or damaged. Leaks can cause fires. Consult your Caterpillar dealer for repair or for replacement parts.

Check lines, tubes, and hoses carefully. Do not use your bare hand to check for leaks. Use a board or cardboard to check for leaks. Tighten all connections to the recommended torque.

Replace the parts if any of the following conditions are present:

- High-pressure fuel line or lines are removed.
- End fittings are damaged or leaking.

- Outer coverings are chafed or cut.
- Wires are exposed.
- Outer coverings are ballooning.
- Flexible parts of the hoses are kinked.
- Outer covers have embedded armoring.
- End fittings are displaced.

Make sure that all clamps, guards, and heat shields are installed correctly. During engine operation, correct installment will help to prevent vibration, rubbing against other parts, and excessive heat.

Regeneration

The exhaust gas temperature during regeneration will be elevated. Follow proper fire prevention instructions and use the disable switch function when appropriate.

i01359666

Crushing Prevention and Cutting Prevention

SMCS Code: 1000; 4450; 7405

Support the component properly when work beneath the component is performed.

Unless other maintenance instructions are provided, never attempt adjustments while the engine is running.

Stay clear of all rotating parts and of all moving parts. Leave the guards in place until maintenance is performed. After the maintenance is performed, reinstall the guards.

Keep objects away from moving fan blades. The fan blades will throw objects or cut objects.

When objects are struck, wear protective glasses in order to avoid injury to the eyes.

Chips or other debris may fly off objects when objects are struck. Before objects are struck, ensure that no one will be injured by flying debris.

i05768982

Mounting and Dismounting

SMCS Code: 1000; 4450; 7405

Do not climb on the engine or the engine aftertreatment system. The engine and aftertreatment system have not been designed with mounting or dismounting locations.

Refer to the OEM for the location of foot and hand holds for your specific application.

i04112191

High Pressure Fuel Lines

SMCS Code: 1274

WARNING

Contact with high pressure fuel may cause fluid penetration and burn hazards. High pressure fuel spray may cause a fire hazard. Failure to follow these inspection, maintenance and service instructions may cause personal injury or death.

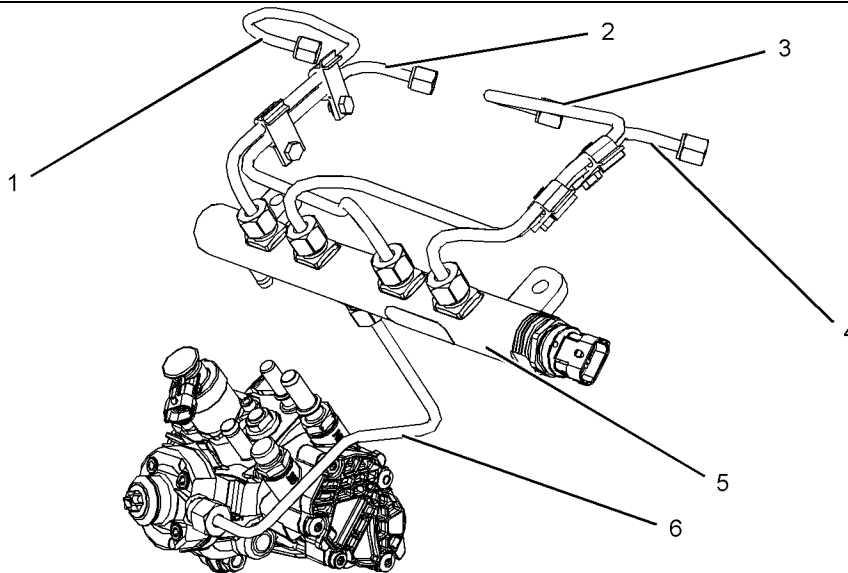

Illustration 11

g02315653

(1) High-pressure line
(2) High-pressure line

(3) High-pressure line
(4) High-pressure line

(5) High-pressure fuel manifold (rail)
(6) Fuel transfer line that is high pressure

The high-pressure fuel lines are the fuel lines that are between the high-pressure fuel pump and the high-pressure fuel manifold and the fuel lines that are between the fuel manifold and cylinder head. These fuel lines are different from fuel lines on other fuel systems.

These differences are because of the following items:

- The high-pressure fuel lines are constantly charged with high pressure.
- The internal pressures of the high-pressure fuel lines are higher than other types of fuel system.
- The high-pressure fuel lines are formed to shape and then strengthened by a special process.

Do not step on the high-pressure fuel lines. Do not deflect the high-pressure fuel lines. Do not bend or strike the high-pressure fuel lines. Deformation or damage of the high-pressure fuel lines may cause a point of weakness and potential failure.

Do not check the high-pressure fuel lines with the engine or the starting motor in operation. After the engine has stopped wait for 10 minutes in order to allow the fuel pressure to be purged from the high-pressure fuel lines before any service or repair is performed.

Do not loosen the high-pressure fuel lines in order to remove air from the fuel system. This procedure is not required.

Visually inspect the high-pressure fuel lines before the engine is started. This inspection should be each day.

If you inspect the engine in operation, always use the proper inspection procedure in order to avoid a fluid penetration hazard. Refer to Operation and Maintenance Manual, "General hazard Information".

- Inspect the high-pressure fuel lines for damage, deformation, a nick, a cut, a crease, or a dent.
- Do not operate the engine with a fuel leak. If there is a leak, do not tighten the connection in order to stop the leak. The connection must only be tightened to the recommended torque. Refer to Disassembly and Assembly, "Fuel injection lines - Remove and Fuel injection lines - Install".
- If the high-pressure fuel lines are torqued correctly, and the high-pressure fuel lines are leaking the high-pressure fuel lines must be replaced.
- Ensure that all clips on the high-pressure fuel lines are in place. Do not operate the engine with clips that are damaged, missing, or loose.
- Do not attach any other item to the high-pressure fuel lines.
- Loosened high-pressure fuel lines must be replaced. Also removed high-pressure fuel lines must be replaced. Refer to Disassembly and Assembly, "Fuel Injection Lines - Install".

i03560601

Before Starting Engine

SMCS Code: 1000

NOTICE

For initial start-up of a new or rebuilt engine, and for start-up of an engine that has been serviced, make provision to shut the engine off should an overspeed occur. This may be accomplished by shutting off the air and/or fuel supply to the engine.

WARNING

Engine exhaust contains products of combustion which may be harmful to your health. Always start and operate the engine in a well ventilated area and, if in an enclosed area, vent the exhaust to the outside.

Inspect the engine for potential hazards.

Do not start the engine or move any of the controls if there is a "DO NOT OPERATE" warning tag or similar warning tag attached to the start switch or to the controls.

Before starting the engine, ensure that no one is on, underneath, or close to the engine. Ensure that the area is free of personnel.

If equipped, ensure that the lighting system for the engine is suitable for the conditions. Ensure that all lights work properly, if equipped.

All protective guards and all protective covers must be installed if the engine must be started in order to perform service procedures. To help prevent an accident that is caused by parts in rotation, work around the parts carefully.

Do not bypass the automatic shutoff circuits. Do not disable the automatic shutoff circuits. The circuits are provided in order to help prevent personal injury. The circuits are also provided in order to help prevent engine damage.

See the Service Manual for repairs and for adjustments.

i04479095

Engine Starting

SMCS Code: 1000

WARNING

Do not use aerosol types of starting aids such as ether. Such use could result in an explosion and personal injury.

If a warning tag is attached to the engine start switch or to the controls, DO NOT start the engine or move the controls. Consult with the person that attached the warning tag before the engine is started.

All protective guards and all protective covers must be installed if the engine must be started in order to perform service procedures. To help prevent an accident that is caused by parts in rotation, work around the parts carefully.

Start the engine from the operators compartment or from the engine start switch.

Always start the engine according to the procedure that is described in the Operation and Maintenance Manual, "Engine Starting" topic in the Operation Section. Knowing the correct procedure will help to prevent major damage to the engine components. Knowing the procedure will also help to prevent personal injury.

Safety Section Engine Stopping

To ensure that the jacket water heater (if equipped) and/or the lube oil heater (if equipped) is working correctly, check the water temperature gauge and/or the oil temperature gauge during the heater operation.

Engine exhaust contains products of combustion which can be harmful to your health. Always start the engine and operate the engine in a well ventilated area. If the engine is started in an enclosed area, vent the engine exhaust to the outside.

These engines are equipped with a glow plug starting aid in each individual cylinder that heats the intake air in order to improve starting.

i03648639

Engine Stopping

SMCS Code: 1000

To avoid overheating of the engine and accelerated wear of the engine components, stop the engine according to this Operation and Maintenance Manual, "Engine Stopping" topic (Operation Section).

Use the Emergency Stop Button (if equipped) **ONLY** in an emergency situation. **DO NOT** use the Emergency Stop Button for normal engine stopping. After an emergency stop, **DO NOT** start the engine until the problem that caused the emergency stop has been corrected.

On the initial start-up of a new engine or an engine that has been serviced, make provisions to stop the engine if an overspeed condition occurs.

i04112409

Electrical System

SMCS Code: 1000; 1400

Never disconnect any charging unit circuit or battery circuit cable from the battery when the charging unit is operating. A spark can cause the combustible gases that are produced by some batteries to ignite.

To help prevent sparks from igniting combustible gases that are produced by some batteries, the negative "-" cable should be connected last from the external power source to the negative "-" terminal of the starting motor. If the starting motor is not equipped with a negative "-" terminal, connect the cable to the engine block.

Check the electrical wires daily for wires that are loose or frayed. Tighten all loose electrical connections before the engine is started. Repair all frayed electrical wires before the engine is started. See the Operation and Maintenance Manual for specific starting instructions.

Grounding Practices

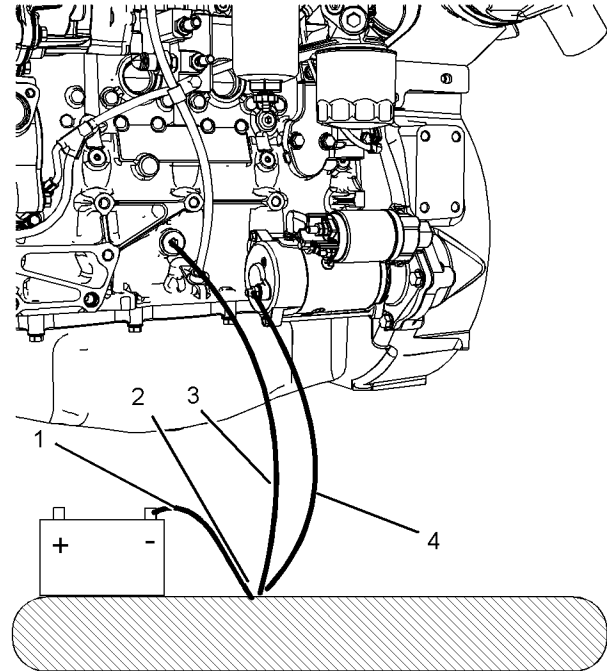

Illustration 12

g02315896

Typical example

- (1) Ground to battery
- (2) Primary position for grounding
- (3) Ground to engine block
- (4) Ground to starting motor

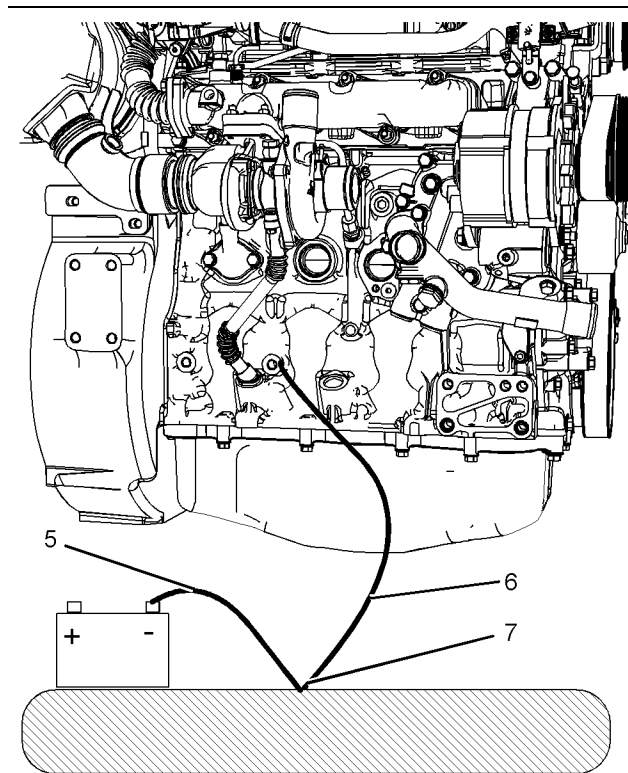

Illustration 13

g02315900

Typical example

- (5) Ground to battery
- (6) Ground to engine block
- (7) Primary position for grounding

Correct grounding for the engine electrical system is necessary for optimum engine performance and reliability. Incorrect grounding will result in uncontrolled electrical circuit paths and in unreliable electrical circuit paths.

Uncontrolled electrical circuit paths can result in damage to engine components.

Engines that are installed without engine-to-frame ground straps can be damaged by electrical discharge.

To ensure the engine and the engine electrical systems function correctly, an engine-to-frame ground strap with a direct path to the battery must be used. This path may be provided by way of a direct engine ground to the frame.

The connections for the grounds should be tight and free of corrosion. The engine alternator must be grounded to the negative “-” battery terminal with a wire adequate to handle the full charging current of the alternator.

The power supply connections and the ground connections for the engine electronics should always be from the isolator to the battery.

i04346349

Engine Electronics

SMCS Code: 1000; 1900

⚠ WARNING

Tampering with the electronic system installation or the OEM wiring installation can be dangerous and could result in personal injury or death and/or engine damage.

⚠ WARNING

Electrical Shock Hazard. The electronic unit injectors use DC voltage. The ECM sends this voltage to the electronic unit injectors. Do not come in contact with the harness connector for the electronic unit injectors while the engine is operating. Failure to follow this instruction could result in personal injury or death.

This engine has a comprehensive, programmable Engine Monitoring System. The Electronic Control Module (ECM) has the ability to monitor the engine operating conditions. If any of the engine parameters extend outside an allowable range, the ECM will initiate an immediate action.

The following actions are available for engine monitoring control:

- Warning
- Derate
- Shutdown

The following monitored engine operating conditions and components have the ability to limit engine speed and/or the engine power:

- Engine Coolant Temperature
- Engine Oil Pressure
- Engine Speed
- Intake Manifold Air Temperature
- Engine Intake Throttle Valve Fault
- Wastegate Regulator
- Supply Voltage to Sensors
- Fuel Pressure in Manifold (Rail)
- NOx Reduction System

- Engine Aftertreatment System

The Engine Monitoring package can vary for different engine models and different engine applications. However, the monitoring system and the engine monitoring control will be similar for all engines.

Product Information Section

General Information

i06703805

Model View Illustrations

SMCS Code: 1000

The following model views show typical features of the engine. Due to individual applications, your engine may appear different from the illustrations.

Engine and Aftertreatment

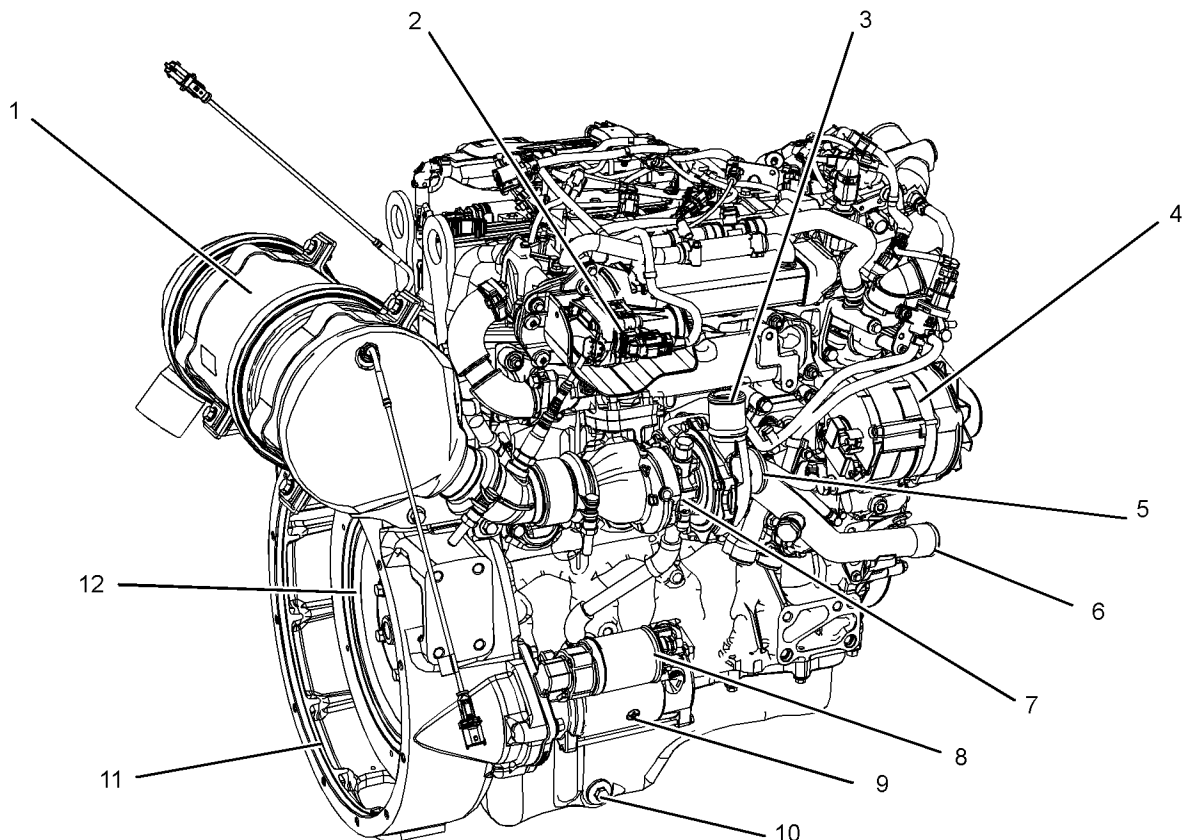

Illustration 14

g03367500

Typical example

- | | | |
|---|---------------------------------|-----------------------|
| (1) Engine aftertreatment system | (5) Air intake from air filter | (9) Starting motor |
| (2) NOx control valve | (6) Coolant intake connection | (10) Oil drain plug |
| (3) Air outlet connection from turbocharger | (7) Turbocharger | (11) Flywheel housing |
| (4) Alternator | (8) Solenoid for starting motor | (12) Flywheel |

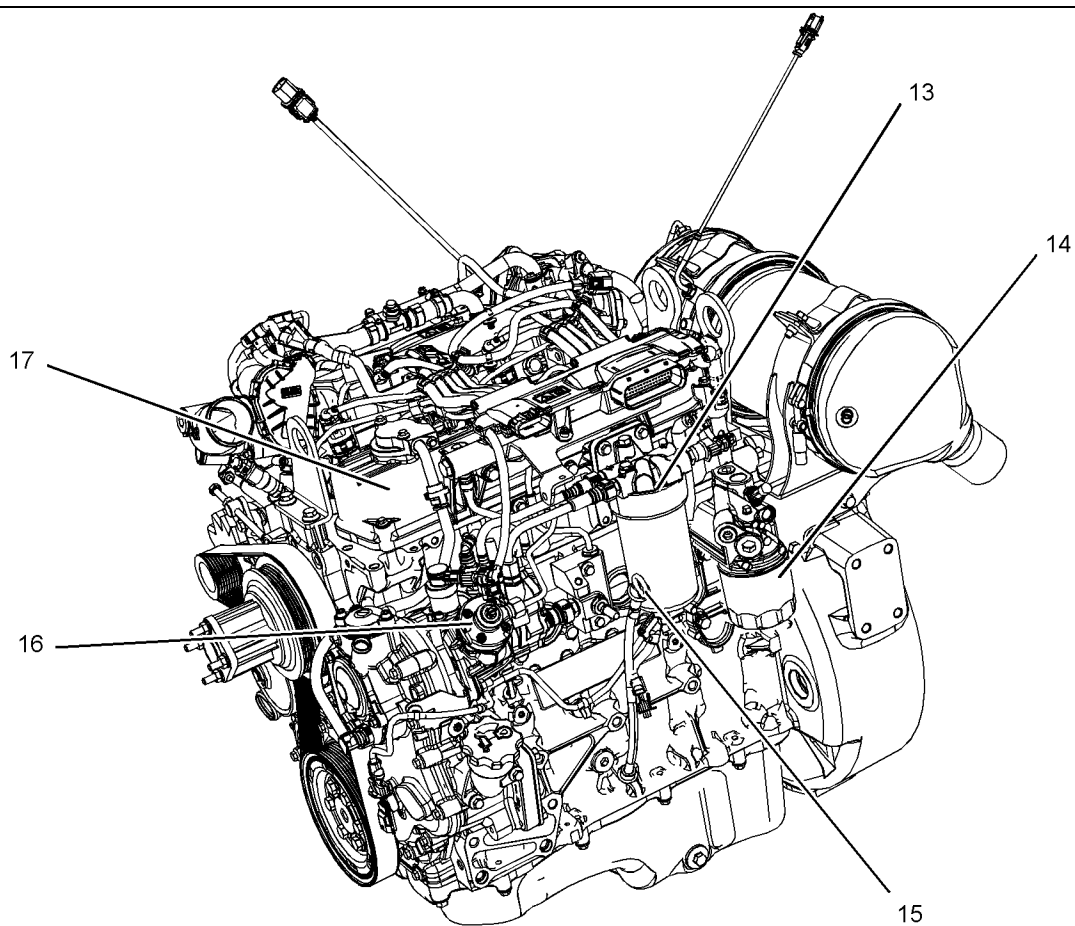

Illustration 15

g03367502

Typical example

(13) Secondary fuel filter
(14) Oil filter(15) Oil level gauge (Dipstick)
(16) High-pressure fuel pump

(17) Valve mechanism cover

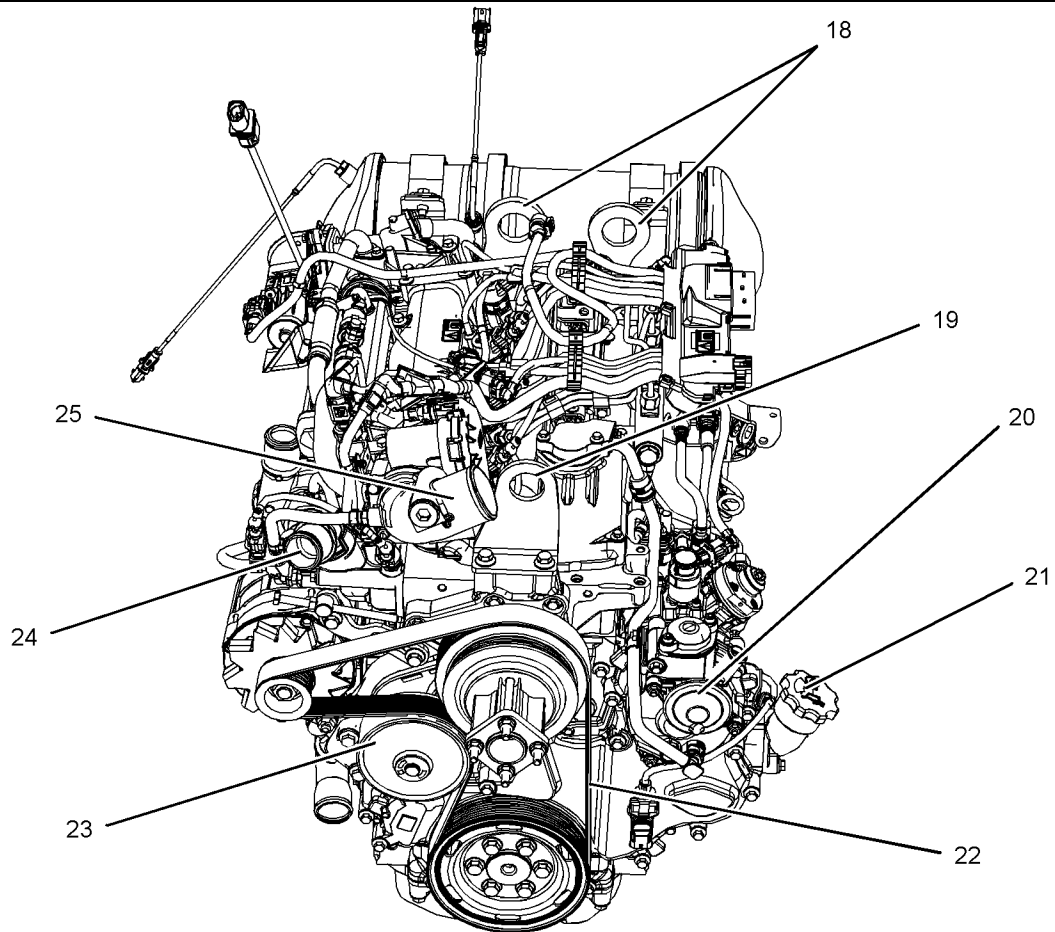

Illustration 16

g03367547

(18) Rear lifting eyes
(19) Front lifting eye
(20) Crankcase breather

(21) Oil filler cap
(22) Belt
(23) Coolant pump

(24) Coolant outlet connection
(25) Air inlet connection

The oil filler cap (21) can also be located on the valve mechanism cover.

Off Engine Parts

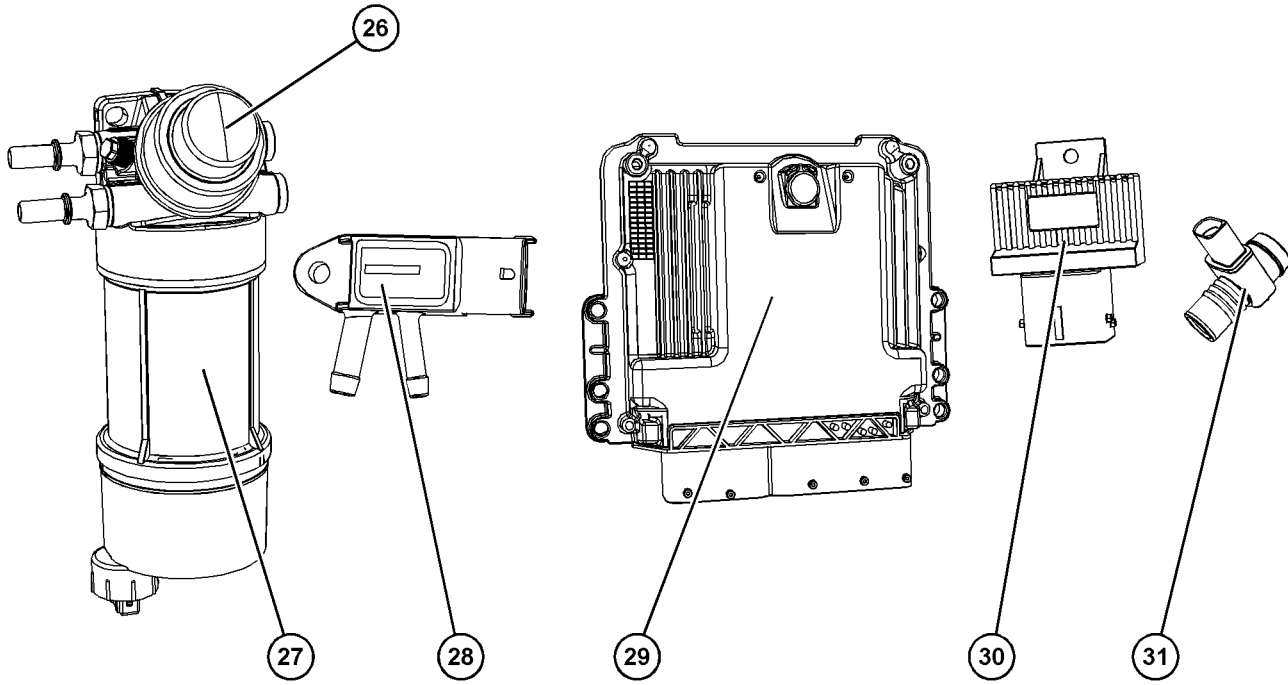

Illustration 17

g06082900

(26) Fuel priming pump
(27) Primary fuel filter

(28) Differential pressure sensor
(29) Electronic control module

(30) Relay for glow plugs
(31) Breather heater

Engine View with Wall Flow Diesel Particulate Filter

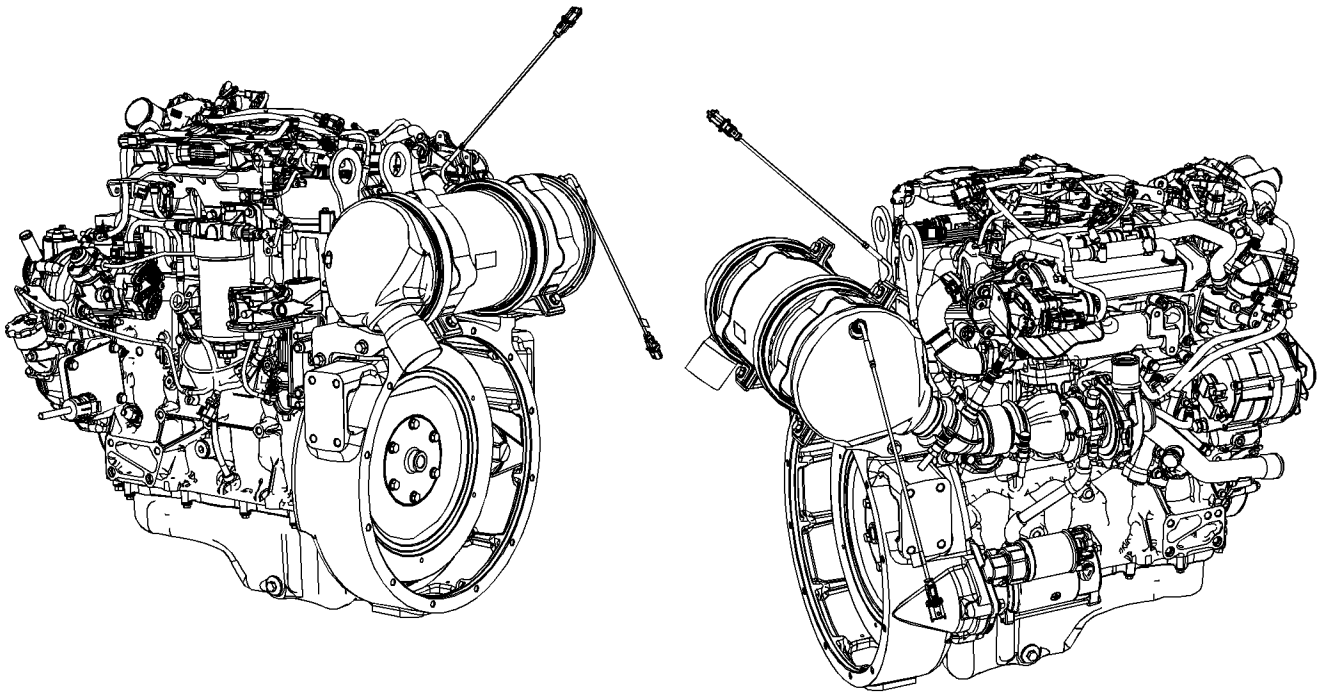

Illustration 18

g03367096

Typical example

The wall flow Diesel Particulate Filter (DPF) will require a service, refer to this Operation and Maintenance Manual, "Maintenance Interval Schedule" for the service period.

Top Mounted Aftertreatment

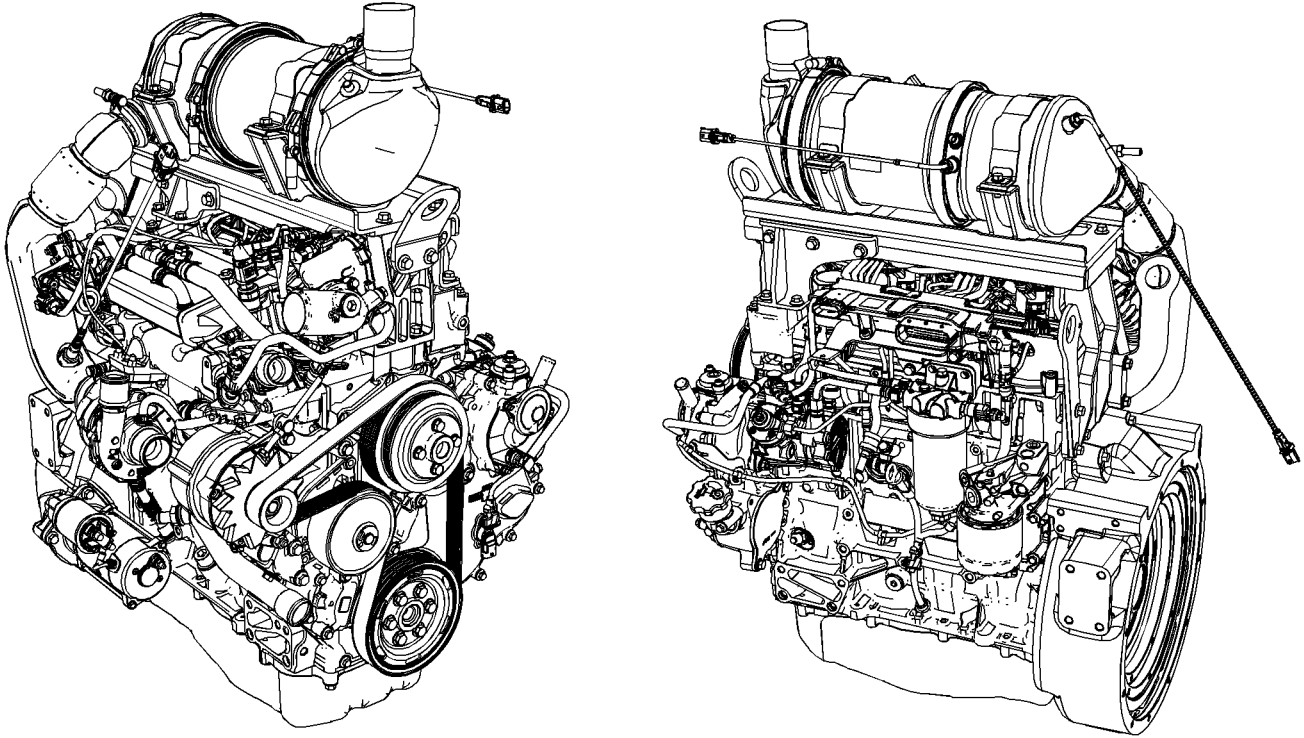

Illustration 19
Typical example

g06082892

The wall flow Diesel Particulate Filter (DPF) will require a service, refer to this Operation and Maintenance Manual, "Maintenance Interval Schedule" for the service period.

Engine View with Through Flow Diesel Particulate Filter

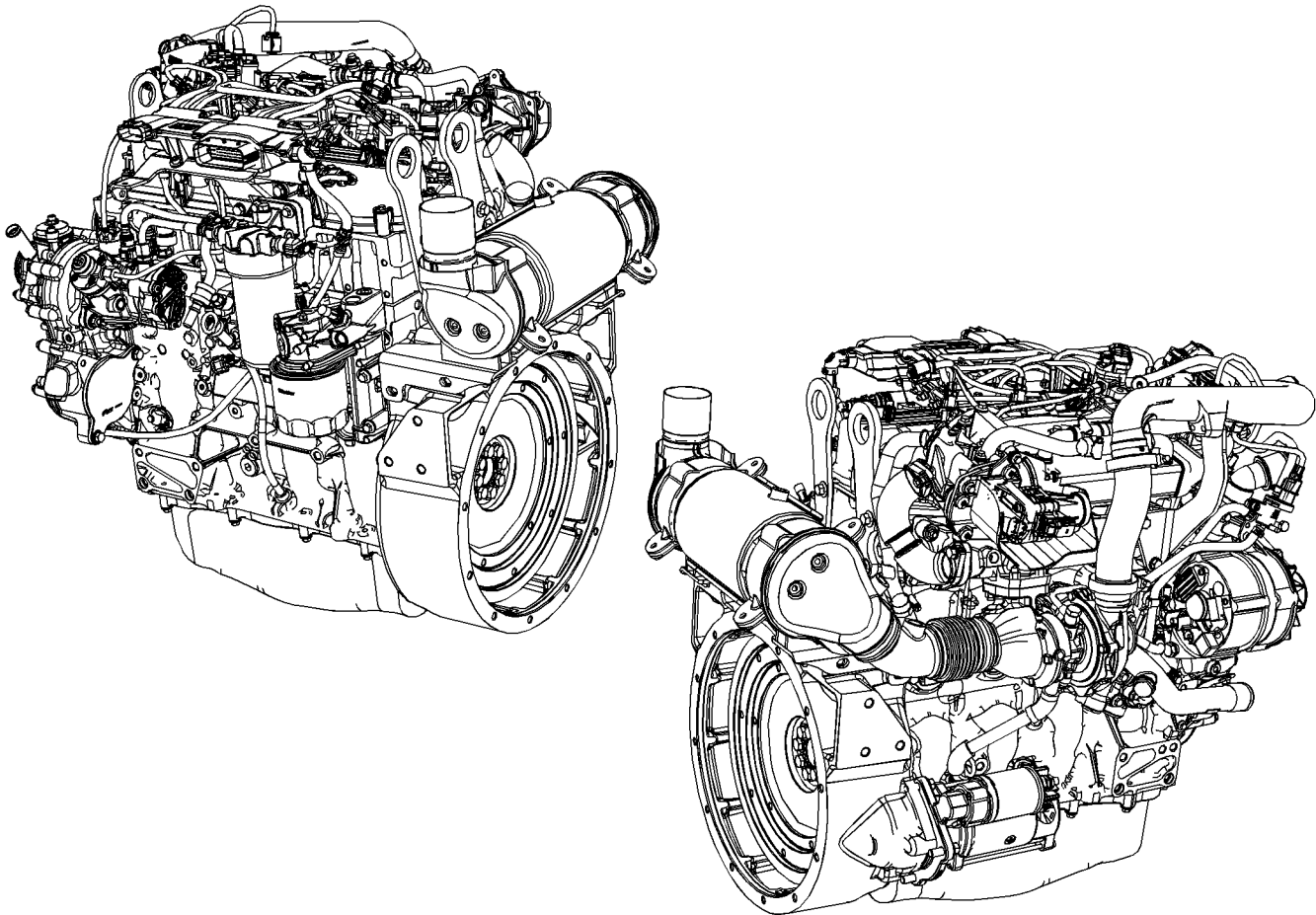

Illustration 20

Typical example

The through-flow type of DPF will not require a service interval.

i06708325

g03367094

Product Description

SMCS Code: 1000; 4450; 4491

The Caterpillar C3.4B industrial engines have the following characteristics

- In-line 4 cylinder
- Two valves for each cylinder

- Four stroke cycle
- Turbocharged
- Turbocharged charge cooled

Engine Specifications

Note: The front end of the engine is opposite the flywheel end of the engine. The left and the right sides of the engine are determined from the flywheel end. The number 1 cylinder is the front cylinder.

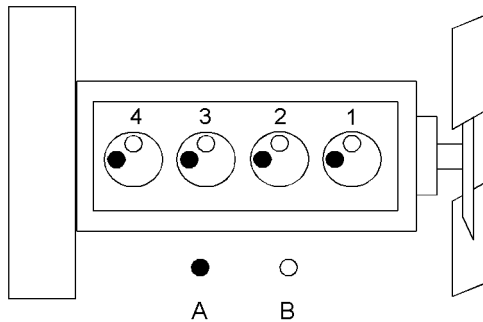

Illustration 21

g06084550

Cylinder and valve location

- (A) Exhaust valves
(B) Inlet valves

Table 1

C3.4B Engine Specifications	
Operating Range (rpm)	800 to 2500 ⁽¹⁾
Number of Cylinders	4 In-Line
Number of valves in cylinder head	8
Bore	99 mm (3.89763 inch)
Stroke	110 mm (4.33070 inch)
Power	45 kW to 55.4 kW (60.345 hp to 74.3 hp) 62 kW to 86 kW (83.142 hp to 115.326 hp)
Aspiration	Turbocharged Turbocharged charge cooled
Compression Ratio	17: 1
Displacement	3.4 L (207.48 cubic inch)
Firing Order	1-3-4-2
Rotation (flywheel end)	Counterclockwise

⁽¹⁾ The operating rpm depends on the engine rating, the application, and the configuration of the throttle.

Engine Type

There are three different types of C3.4B engines and aftertreatment.

- Turbocharged engine with wall flow Diesel Particulate Filter (DPF)
- Turbocharged, charge cooled with wall flow DPF
- Turbocharged, charge cooled with through flow DPF

The engine is available as a variable speed engine, constant speed engine, and a constant power output engine.

Aftertreatment Type

There are two different types of aftertreatment that can be installed, the wall flow DPF and the through-flow DPF. The through-flow DPF will not require a maintenance interval.

The wall flow DPF will require a maintenance interval, refer to this Operation and Maintenance Manual, "Maintenance Interval Schedule" more information.

Electronic Engine Features

The engine operating conditions are monitored. The Electronic Control Module (ECM) controls the response of the engine to these conditions and to the demands of the operator. These conditions and operator demands determine the precise control of fuel injection by the ECM. The electronic engine control system provides the following features:

- Engine monitoring
- Engine speed governing
- Control of the injection pressure
- Cold start strategy
- Automatic air/fuel ratio control
- Torque rise shaping
- Injection timing control
- System diagnostics
- Aftertreatment Regeneration

For more information on electronic engine features, refer to the Operation and Maintenance Manual, "Features and Controls" topic (Operation Section).

Engine Diagnostics

The engine has built-in diagnostics to ensure that the engine systems are functioning correctly. The operator will be alerted to the condition by a "Stop or Warning" lamp. Under certain conditions, the engine horsepower and the vehicle speed may be limited. The electronic service tool may be used to display the diagnostic codes.

There are three types of diagnostic codes: active, logged, and event.

Most of the diagnostic codes are logged and stored in the ECM. For additional information, refer to the Operation and Maintenance Manual, "Engine Diagnostics" topic (Operation Section).

The ECM provides an electronic governor that controls the injector output to maintain the desired engine rpm.

Engine Cooling and Lubrication

The cooling system and lubrication system consists of the following components:

- Belt driven centrifugal water pump
- Water temperature regulator which regulates the engine coolant temperature
- Gear-driven rotor type oil pump
- Multi-plate oil cooler

The engine lubricating oil is cooled and the engine lubricating oil is filtered.

Engine Service Life

Engine efficiency and maximum utilization of engine performance depend on the adherence to proper operation and maintenance recommendations. In addition, use recommended fuels, coolants, and lubricants. Use the Operation and Maintenance Manual as a guide for required engine maintenance.

Aftermarket Products and Caterpillar Engines

Caterpillar does not warrant the quality or performance of non-Caterpillar fluids and filters.

When auxiliary devices, accessories, or consumables (filters, additives, catalysts,) which are made by other manufacturers are used on Caterpillar products, the Caterpillar warranty is not affected simply because of such use.

However, failures that result from the installation or use of other manufacturers devices, accessories, or consumables are NOT Caterpillar defects. Therefore, the defects are NOT covered under the Caterpillar warranty.

Aftertreatment System

The aftertreatment system is approved for use by Caterpillar. To be emission-compliant, only the approved Caterpillar aftertreatment system must be used on a Caterpillar engine.

Product Identification Information

i04394062

Plate Locations and Film Locations (Engine)

SMCS Code: 1000; 4450

Caterpillar dealers need all of these numbers in order to determine the components that were included with the engine. This information permits accurate identification of replacement part numbers.

The numbers for fuel setting information for electronic engines are stored within the flash file. These numbers can be read by using the electronic service tool.

Serial Number location

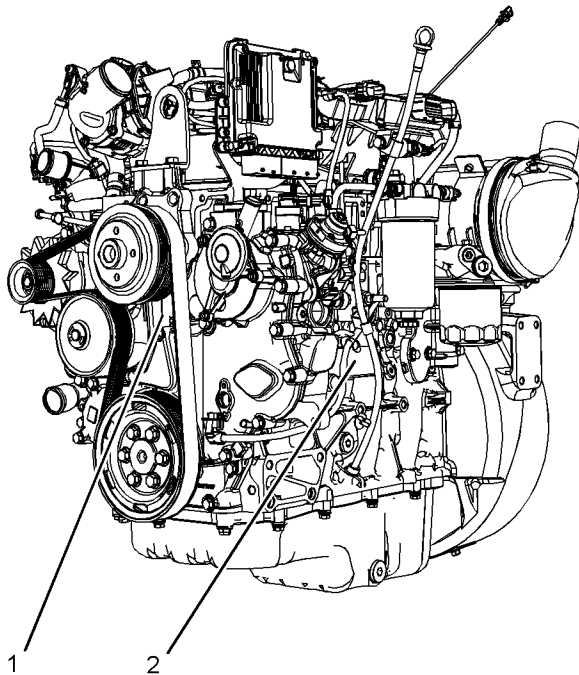

Illustration 22

g02474416

Typical example of a non-stressed cylinder block

The engine serial number can be installed in three different positions.

All engines will have the serial number install in location (1) on the front face of the engine.

On a non-stressed cylinder block the serial number is located in position (2). On the left-hand side on the cylinder block.

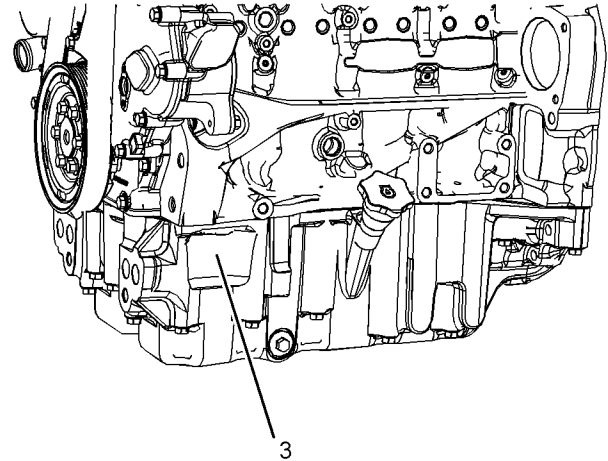

Illustration 23

g02832639

Typical example

On a stressed cylinder block the serial number is located in position (3).

The engine serial number will be stamped on the emissions plate.

i05328152

Plate Locations and Film Locations

(Aftertreatment)

SMCS Code: 1000; 4450

Wall Flow Diesel Particulate Filter (DPF)

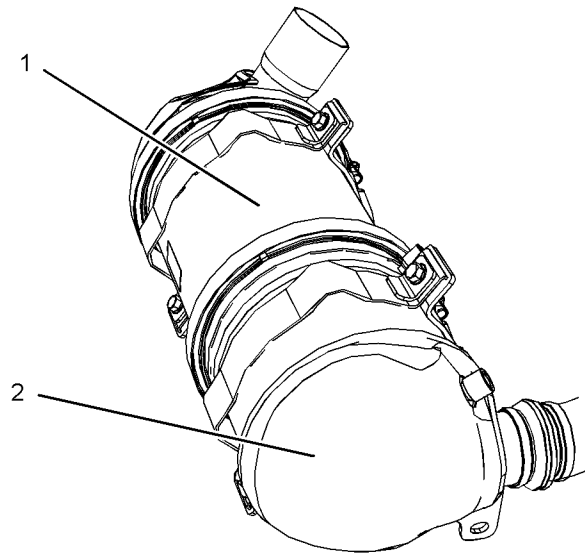

Illustration 24

g02475495

Typical example

The serial number for identifying the aftertreatment will be in two locations. On the DPF in position (1) and in position (2). On the end cover of the inlet to the DPF.

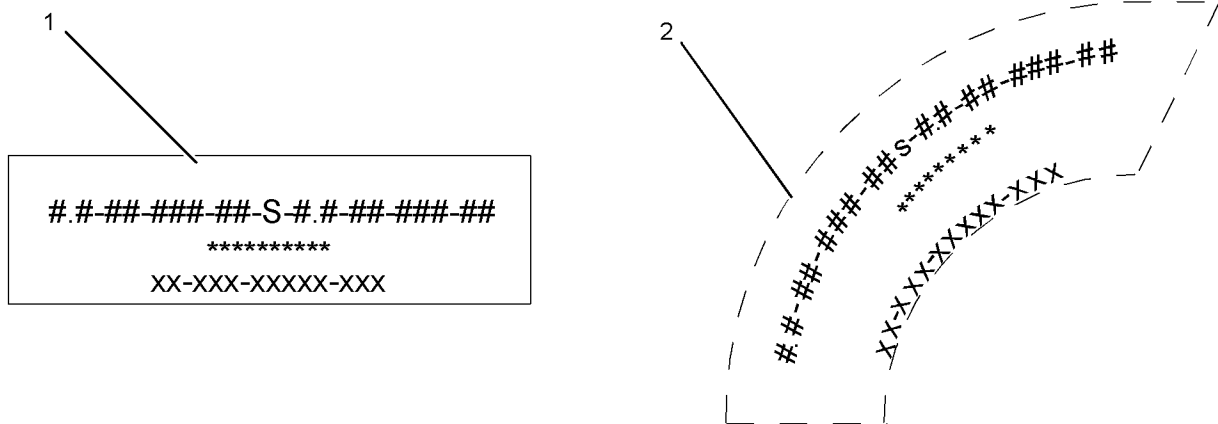

Illustration 25

g02723697

(1) Serial numbers on main body

(2) Serial numbers on inlet end cover

Ensure that all numbers on the aftertreatment are recorded.

Your Cat dealer will require all the numbers in order to identify the components for your aftertreatment.

i05328174

Plate Locations and Film Locations (Aftertreatment)

SMCS Code: 1000; 4450

Through-Flow Diesel Particulate Filter (DPF)

A serial number label for identifying the through-flow DPF will be located on the main body of the DPF.

i04460799

Emissions Certification Film

SMCS Code: 1000; 7405

The emission label will be installed on the left side of the non-stressed cylinder block.

EMISSION CONTROL INFORMATION	
ENGINE FAMILY <input style="width: 50px;" type="text" value="####"/> MODEL <input style="width: 50px;" type="text" value="####"/> MANUFACTURE DATE (MO-YR) <input style="width: 80px;" type="text" value="####"/>	ENGINE TYPE <input style="width: 40px;" type="text" value="####"/> <input style="width: 40px;" type="text" value="####"/>
DISPLACEMENT <input style="width: 50px;" type="text" value="####"/> ADVERTISED POWER <input style="width: 50px;" type="text" value="####"/> KW@rpm POWER CATEGORY: <input style="width: 50px;" type="text" value="####"/>	SERIAL NUMBER <input style="width: 100px;" type="text" value="#### ####"/>
THIS ENGINE COMPLIES WITH US. EPA REGULATION FOR <input style="width: 50px;" type="text" value="####"/> MODEL YEAR NON ROAD AND STATIONARY DIESEL ENGINE AND CALIFORNIA REGULATION FOR <input style="width: 50px;" type="text" value="####"/> MODEL YEAR NON ROAD DIESEL ENGINES	E# <input style="width: 40px;" type="text" value="####"/> <input style="width: 40px;" type="text" value="####"/>
THIS ENGINE IS CERTIFIED TO OPERATE ON: ULTRA LOW SULFUR FUEL ONLY ECS: <input style="width: 50px;" type="text" value="####"/> <input style="width: 50px;" type="text" value="####"/>	<input style="width: 100px;" type="text" value="####"/>
MANUFACTURED BY FPT INDUSTRIAL S.P.A. IN ITALY	<input style="width: 30px;" type="text" value="####"/> <input style="width: 30px;" type="text" value="####"/> <input style="width: 30px;" type="text" value="####"/>

Illustration 26

g02646428

Typical example

i05324886

Engine Aftertreatment System

Part Number _____

Serial Number _____

Reference Information

SMCS Code: 1000; 4450

Information for the following items may be needed to order parts. Locate the information for your engine. Record the information in the appropriate space. Make a copy of this list for a record. Keep the information for future reference.

Record for Reference

Engine Model _____

Engine Serial Number _____

Engine Low Idle Revolutions Per Minute (RPM) _____

Engine Full Load RPM _____

Primary Fuel Filter _____

Secondary Fuel Filter Element _____

Lubrication Oil Filter Element _____

Auxiliary Oil Filter Element _____

Total Lubrication System Capacity _____

Total Cooling System Capacity _____

Air Cleaner Element _____

Drive Belt _____

Operation Section

Lifting and Storage

i06708244

Product Lifting

SMCS Code: 7000; 7002

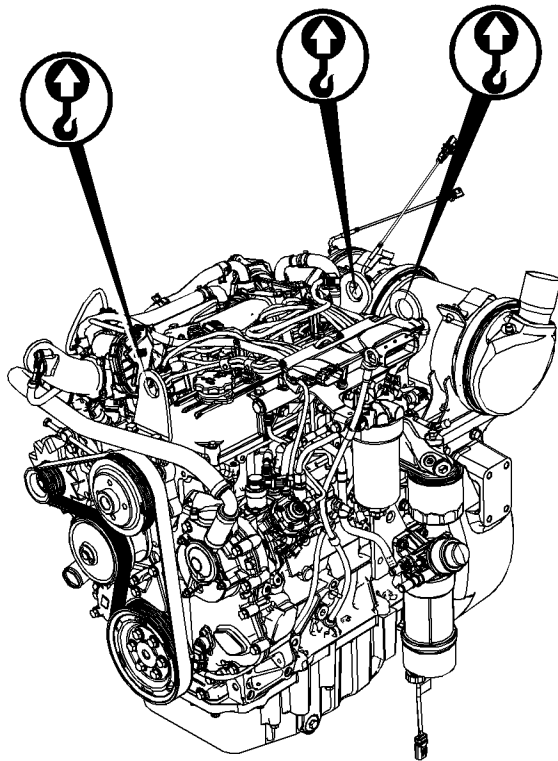

Illustration 27

g02475658

Typical example

NOTICE

Never bend the eyebolts and the brackets. Only load the eyebolts and the brackets under tension. Remember that the capacity of an eyebolt is less as the angle between the supporting members and the object becomes less than 90 degrees.

When it is necessary to remove a component at an angle, only use a link bracket that is properly rated for the weight.

Use a hoist to remove heavy components. Use an adjustable lifting beam to lift the engine. All supporting members (chains and cables) should be parallel to each other. The chains and cables should be perpendicular to the top of the object that is being lifted.

Some removals require lifting the fixtures to obtain correct balance and safety.

To remove the engine, use the lifting eyes that are on the engine. Radiators that are approved by Caterpillar can be lifted with the engine.

Lifting eyes are designed and installed for specific engine arrangements. Alterations to the lifting eyes and/or the engine make the lifting eyes and the lifting fixtures obsolete. If alterations are made, ensure that correct lifting devices are provided. Consult your Cat dealer for information regarding fixtures for correct engine lifting.

Note: The engine is equipped with three lifting eyes. All the lifting eyes must be used to lift the engine.

i04342749

Product Storage

SMCS Code: 7002

If the engine will not be started for several weeks, the lubricating oil will drain from the cylinder walls and from the piston rings. Rust can form on the cylinder liner surface. Rust on the cylinder liner surface will cause increased engine wear and a reduction in engine service life.

To help prevent excessive engine wear, use the following guidelines:

- Complete all of the lubrication recommendations that are listed in this Operation and Maintenance Manual, "Maintenance Interval Schedule" (Maintenance Section).
- If freezing temperatures are expected, check the cooling system for adequate protection against freezing. See this Operation and Maintenance Manual, "Refill Capacities and Recommendations" (Maintenance Section).

If an engine is out of operation and if use of the engine is not planned, special precautions should be made. If the engine will be stored for more than one month, a complete protection procedure is recommended.

For more detailed information on engine storage, see Special Instruction, SEHS9031, "Storage Procedure For Caterpillar Products".

Your Cat dealer can assist in preparing the engine for extended storage periods.

Features and Controls

i05324913

Alarms and Shutoffs

SMCS Code: 7400

The alarm is a warning to the operator that an abnormal operating condition has occurred. The shutoffs are set in order to protect the engine from damage. A shutoff can be triggered by pressure, temperature, engine speed, and electronic fault.

The operator should become familiar with the warning lamps and shutdown lamps on the installed control panel before operating the application. For more information refer to this Operation and Maintenance Manual, "Monitoring System (Table for the Indicator lamps)".

i04394114

Gauges and Indicators

SMCS Code: 7450

Your engine may not have the same gauges or all of the gauges that are described. For more information about the gauge package, see the OEM information.

Gauges provide indications of engine performance. Ensure that the gauges are in good working order. Determine the normal operating range by observing the gauges over a period.

Noticeable changes in gauge readings indicate potential gauge or engine problems. Problems may also be indicated by gauge readings that change even if the readings are within specifications. Determine and correct the cause of any significant change in the readings. Consult your Caterpillar dealer for assistance.

Some engine applications are equipped with Indicator Lamps. Indicator lamps can be used as a diagnostic aid. There are two lamps. One lamp has an orange lens and the other lamp has a red lens.

These indicator lamps can be used in two ways:

- The indicator lamps can be used to identify the current operational status of the engine. The indicator lamps can also indicate that the engine has a fault. This system is automatically operated via the ignition switch.
- The indicator lamps can be used to identify active diagnostic codes. This system is activated by pressing the Flash Code button.

Refer to the Troubleshooting Guide, "Indicator Lamps" for further information.

NOTICE

If no oil pressure is indicated, STOP the engine. If maximum coolant temperature is exceeded, STOP the engine. Engine damage can result.



Engine Oil Pressure – The oil pressure should be greatest after a cold engine is started. The typical engine oil pressure with SAE10W40 is 400 to 480 kPa (58 to 69 psi) at rated rpm.

A lower oil pressure is normal at low idle. If the load is stable and the gauge reading changes, perform the following procedure:

1. Remove the load.
2. Stop the engine.
3. Check and maintain the oil level.



Jacket Water Coolant Temperature – Typical temperature range is 82° to 94° C (179.6° to 169.2°F). This temperature range will vary according to engine load and the ambient temperature.

A 100 kPa (14.5 psi) radiator cap must be installed on the cooling system. The maximum temperature for the cooling system is 108° C (226.4° F). The engine coolant temperature is regulated by the engine sensors and the engine ECM. This programming cannot be altered. An engine derate can occur if the maximum engine coolant temperature is exceeded.

If the engine is operating above the normal range, reduce the engine load. If high coolant temperatures are a frequent event, perform the following procedures:

1. Reduce the load and the engine rpm.
2. Determine if the engine must be shut down immediately or if the engine can be cooled by reducing the load.
3. Inspect the cooling system for leaks. If necessary, consult your Caterpillar dealer for assistance.



Tachometer – This gauge indicates engine speed (rpm). When the throttle control lever is moved to the full throttle position without load, the engine is running at high idle. The engine is running at the full load rpm when the throttle control lever is at the full throttle position with maximum rated load.

NOTICE

To help prevent engine damage, never exceed the high idle rpm. Over speeding can result in serious damage to the engine. Operation at speeds exceeding high idle rpm should be kept to a minimum.



Ammeter – This gauge indicates the amount of charge or discharge in the battery charging circuit. Operation of the indicator should be to the “+” side of “0” (zero).



Fuel Level – This gauge indicates the fuel level in the fuel tank. The fuel level gauge operates when the “START/STOP” switch is in the “on” position.



Service Hour Meter – The gauge indicates total operating hours of the engine.

Indicator Lamps

- Shutdown lamp
- Warning lamp
- Wait to start lamp
- Low oil pressure lamp (On solid) and engine oil reset lamp (Flashing)

For information, refer to this manual, “Monitoring System (Table for the Indicator Lamps)” for the sequence of operation of the shutdown lamp and the warning lamp.

The function of the wait to start lamp is automatically controlled at engine start-up.

The low oil pressure lamp has two functions.

- The low oil pressure lamp is controlled by the engine ECM. If low oil pressure is detected, the lamp will be illuminated on solid. The reason for the illumination of the low-pressure lamp should be investigated immediately.
- Low oil pressure lamp flashing, an engine oil change is required. The lamp must be reset, refer to this Operation and Maintenance Manual, “Engine Oil and Filter - Change” for more information.

All lamps will illuminate for 2 seconds in order to check that the lamps are functioning when the keyswitch is turned to the ON position. If any of the lamps stay illuminated, the reason for illumination should be investigated immediately.

Aftertreatment Lamps

For information on the aftertreatment lamp, refer to this Operation and Maintenance Manual, “Diesel Particulate Filter Regeneration”.

i06709098

Monitoring System

SMCS Code: 1900; 7400; 7450; 7451

WARNING

If the Shutdown mode has been selected and the warning indicator activates, engine shutdown may take as little as 20 seconds from the time the warning indicator is activated. Depending on the application, special precautions should be taken to avoid personal injury. The engine can be re-started following shutdown for emergency maneuvers, if necessary.

NOTICE

The Engine Monitoring System is not a guarantee against catastrophic failures. Programmed delays and derate schedules are designed to minimize false alarms and provide time for the operator to stop the engine.

The following parameters are monitored:

- Coolant temperature
- Intake manifold air temperature
- Intake manifold air pressure
- Oil pressure
- Pressure in the fuel rail
- Engine speed/timing
- Fuel temperature
- Atmospheric pressure (Barometric pressure)
- Water in fuel switch
- Inlet temperature of the diesel oxidation catalyst
- Inlet temperature of the diesel particulate filter
- Differential pressure in the diesel particulate filter (wall flow filter only)

- The amount of soot in the diesel particulate filter

Programmable Options and Systems Operation

WARNING

If the Warning/Derate/Shutdown mode has been selected and the warning indicator activates, bring the engine to a stop whenever possible. Depending on the application, special precautions should be taken to avoid personal injury.

The engine can be programmed to the following modes:

“Warning”

The orange “Warning” lamp will turn “ON” and the warning signal is activated continuously to alert the operator that one or more of the engine parameters is not within normal operating range.

“Derate”

The orange “Warning” lamp will “flashing” . After the warning, the engine power will be derated.

The engine will be derated if the engine exceeds preset operational limits. The engine derate is achieved by restricting the amount of fuel that is available for each injection. The reduction of fuel depends on the severity of the fault that has caused the engine derate, typically up to a limit of 50 percent. This reduction in fuel results in a predetermined reduction in engine power.

“Shutdown”

The orange warning will turn “ON” and the red shutdown lamp will also turn “ON” . After the warning, the engine power will be derated. The engine will continue at the rpm of the set derate until a shutdown of the engine occurs. The engine can be restarted after a shutdown for use in an emergency.

A shutdown of the engine may occur in as little as 20 seconds. The engine can be restarted after a shutdown for use in an emergency. However, the cause of the initial shutdown may still exist. The engine may shut down again in as little as 20 seconds.

If there is a signal for high coolant temperature, there will be a 2 second delay to verify the condition.

If there is a signal for low oil pressure, there will be a 2 second delay to verify the condition.

For information on the operation of the warning lamps and the shutdown lamp, refer to this Operation and Maintenance Manual, “Monitoring System (Table for Indicator Lamps)”. For each of the programmed modes, refer to Troubleshooting Guide, “Indicator Lamps” for more information on Indicator Lamps.

For more information or assistance for repairs, consult your Cat dealer.

i04348489

Overspeed

SMCS Code: 1900; 1907; 1912; 7427

- ECM _____ Electronic Control Module
- RPM _____ Revolutions Per Minute

An overspeed is detected by the speed/timing sensors.

The default overspeed is set at 2800. The ECM will cut the power to the electronic unit injectors, until the rpm drops below the overspeed setting. A diagnostic fault code will be logged into the ECM memory and a warning lamp will indicate a diagnostic fault code. Some application may have a display panel in order to alert the operator.

i05325438

Sensors and Electrical Components

SMCS Code: 1900; 7400

Full Engine Views

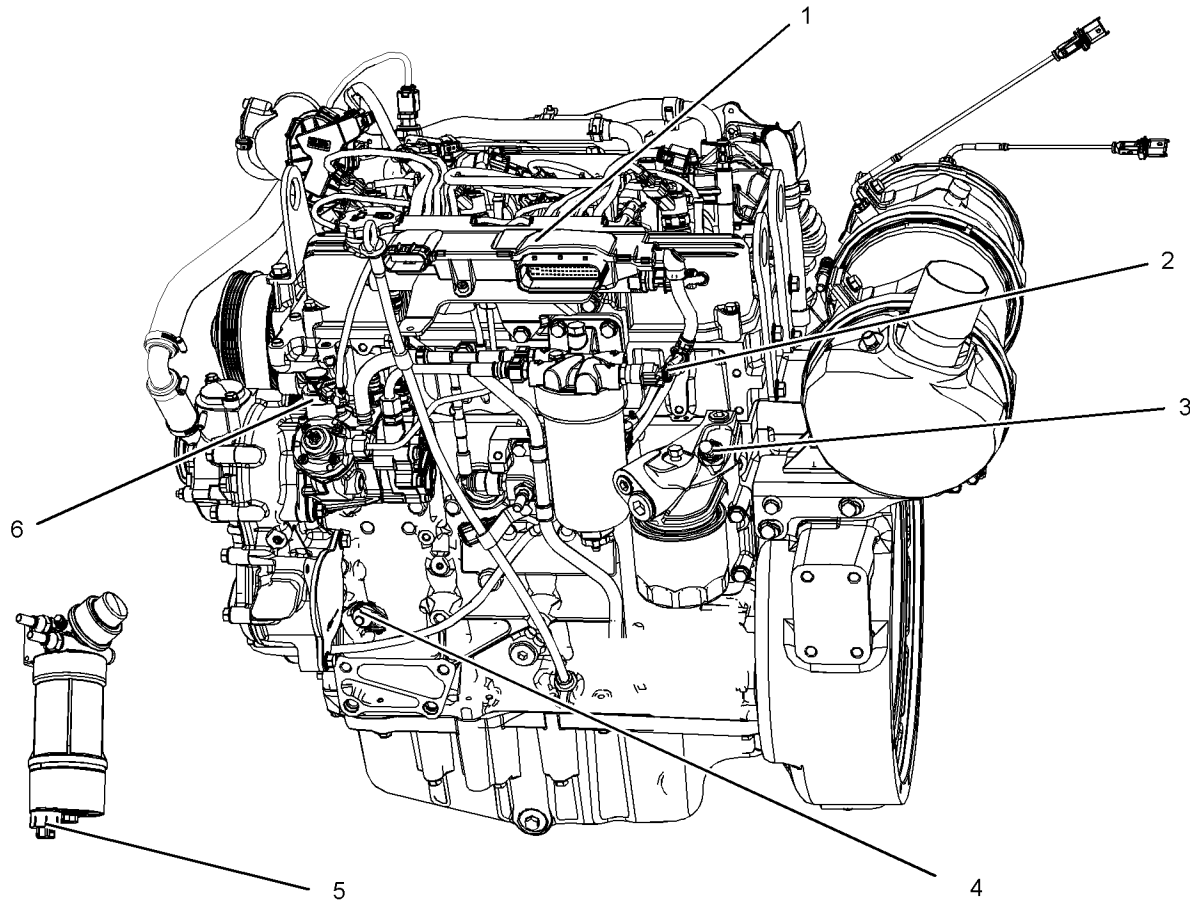

Illustration 28

g03373765

Typical example

- (1) 10 Pin and 62 pin connector
- (2) Fuel temperature sensor
- (3) Oil pressure switch

- (4) Primary speed/timing sensor (crankshaft position sensor)
- (5) Water in fuel switch

- (6) Fuel metering valve

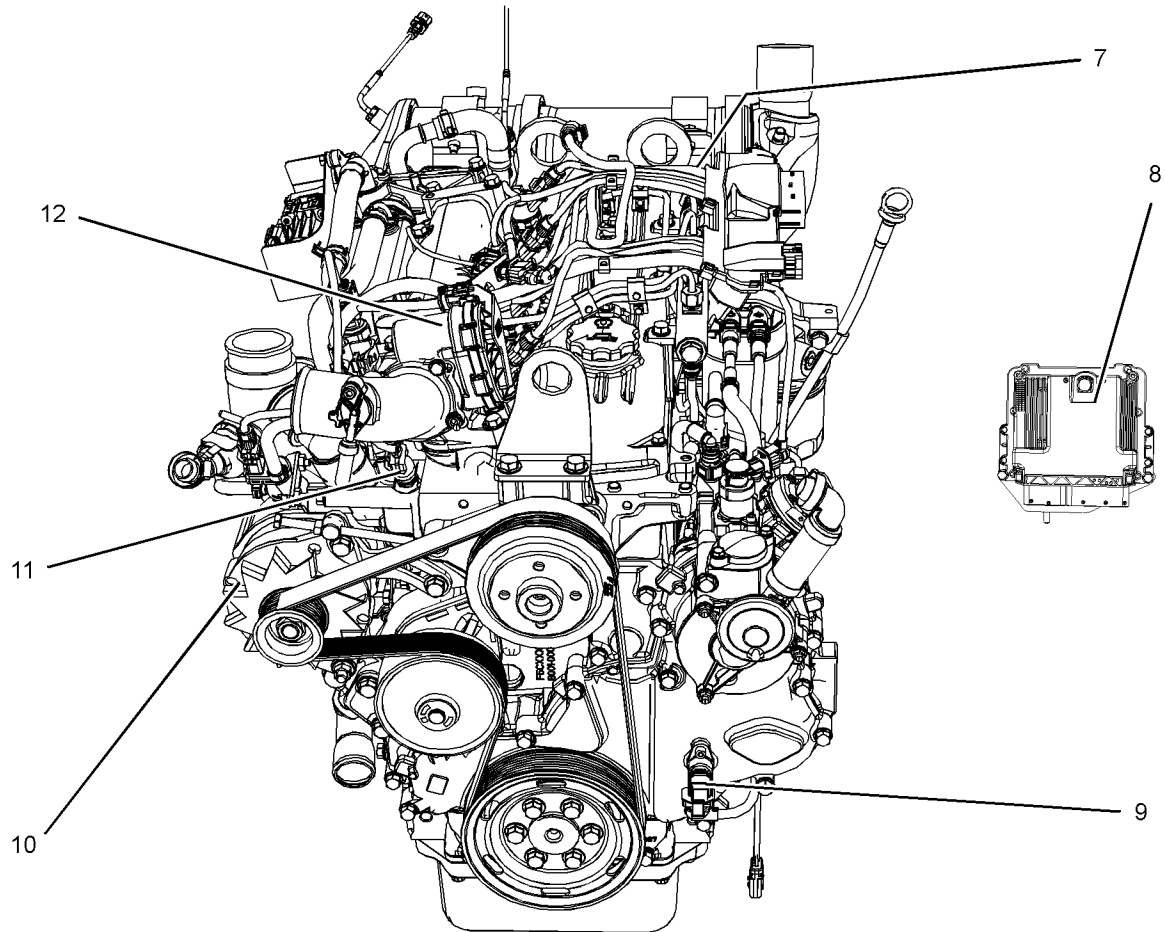

Illustration 29

g02477200

Typical example

(7) Fuel manifold (rail) pressure sensor
(8) Electronic control module

(9) Secondary speed/timing sensor
(camshaft position sensor)
(10) Alternator

(11) Coolant temperature sensor
(12) Intake throttle valve

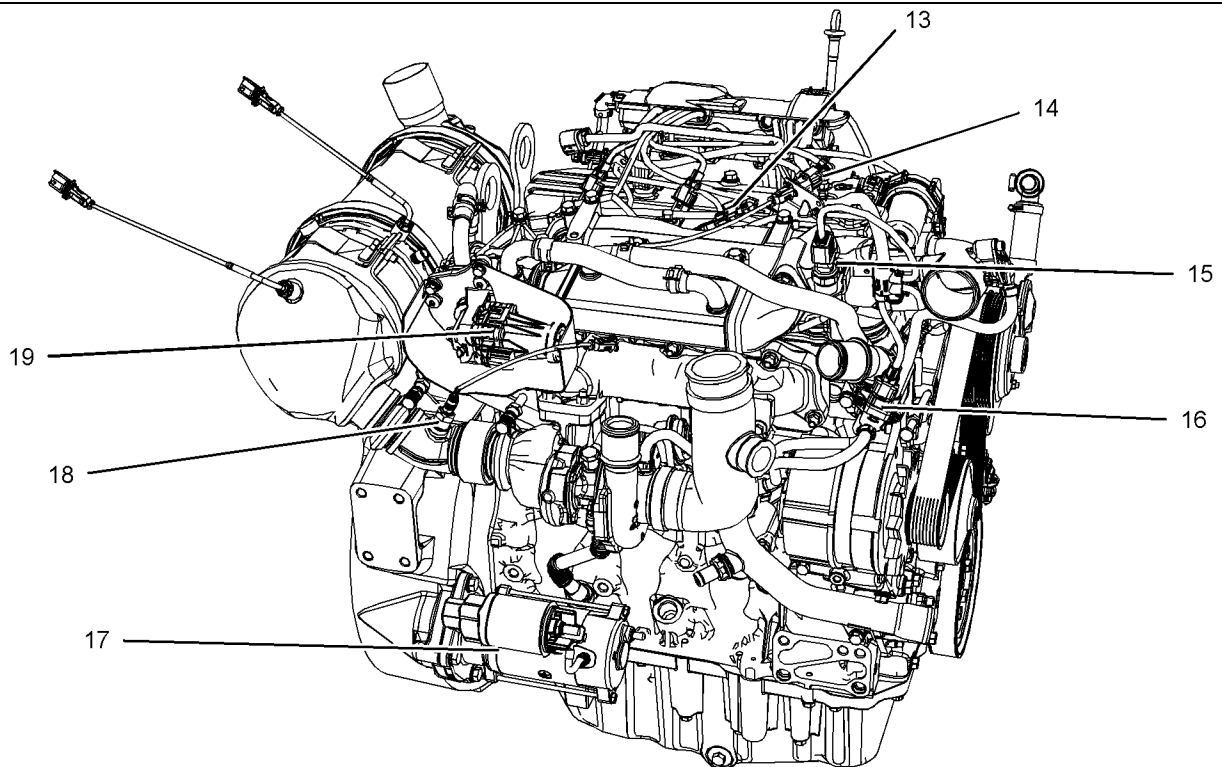

Illustration 30

g02529496

Typical example

(13) Inlet manifold pressure and temperature sensor.
(14) Exhaust temperature sensor connection

(15) Exhaust pressure sensor
(16) Waste gate regulator
(17) Starting motor
(18) Oxygen sensor

(19) Control valve for the NOx reduction system

Note: Item (13), lower powered engines have separate inlet manifold pressure sensors and inlet manifold temperature sensors.

Engine View Low Power with Separate Inlet Pressure and Inlet Temperature

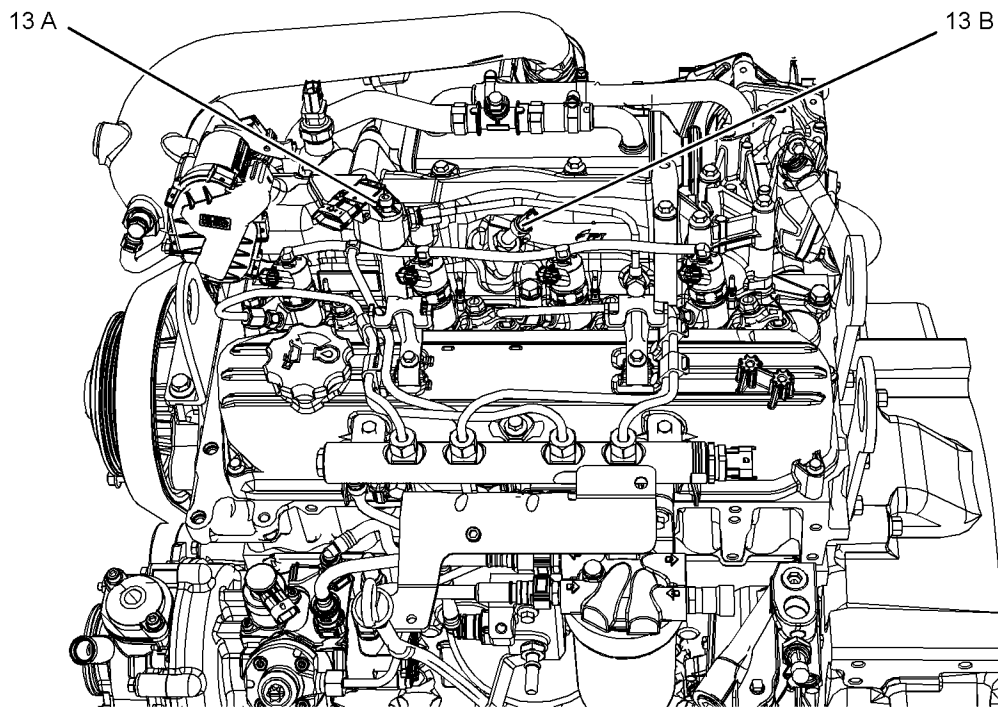

Illustration 31

g03373789

Typical example

(13 A) Inlet pressure sensor

(13 B) Inlet temperature sensor

Location Views

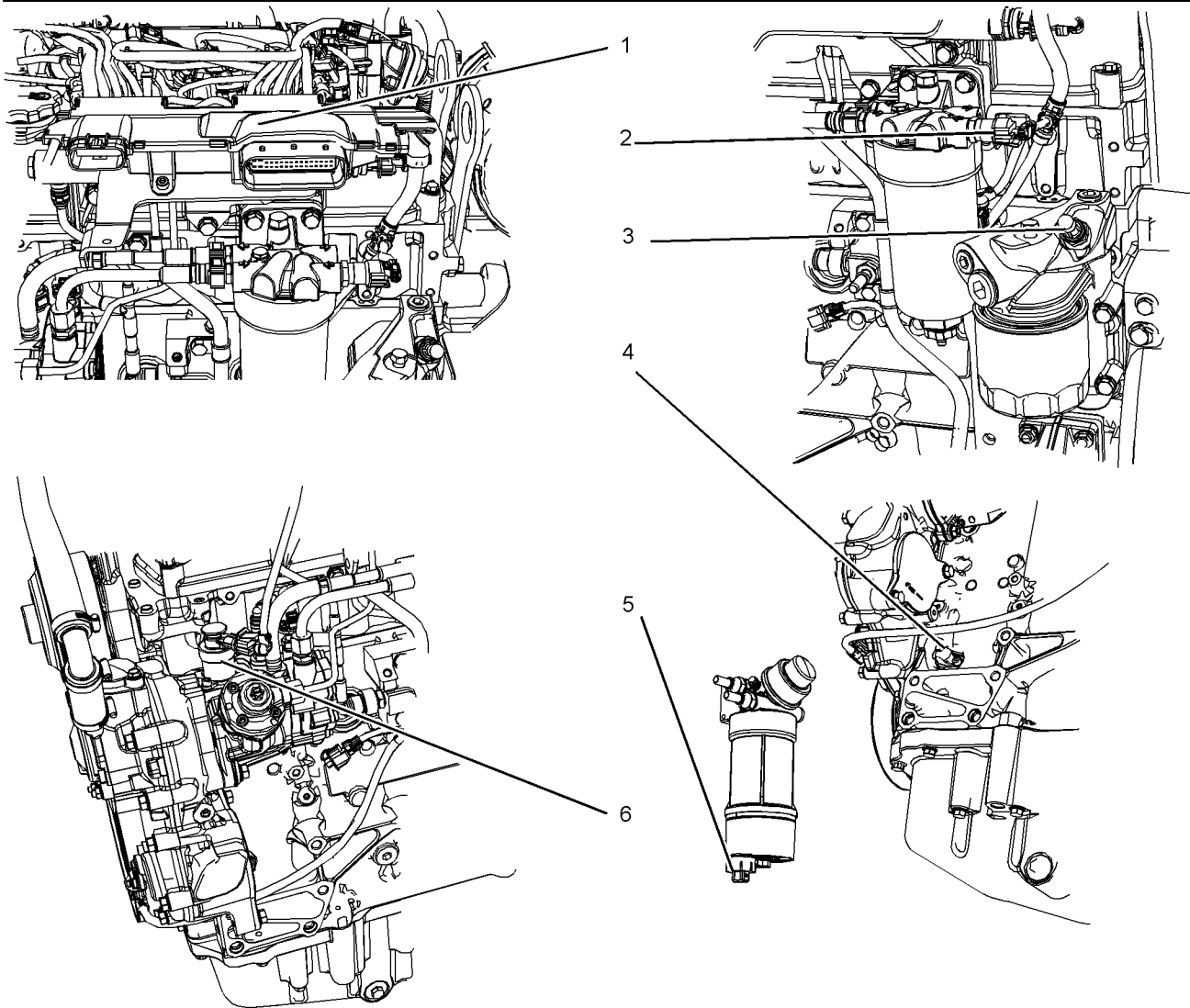

Illustration 32

g03373767

Typical example

- (1) 10 Pin and 62 pin connector
- (2) Fuel temperature sensor
- (3) Oil pressure switch

- (4) Primary speed/timing sensor (crankshaft position sensor)
- (5) Water in fuel switch

- (6) Fuel metering valve

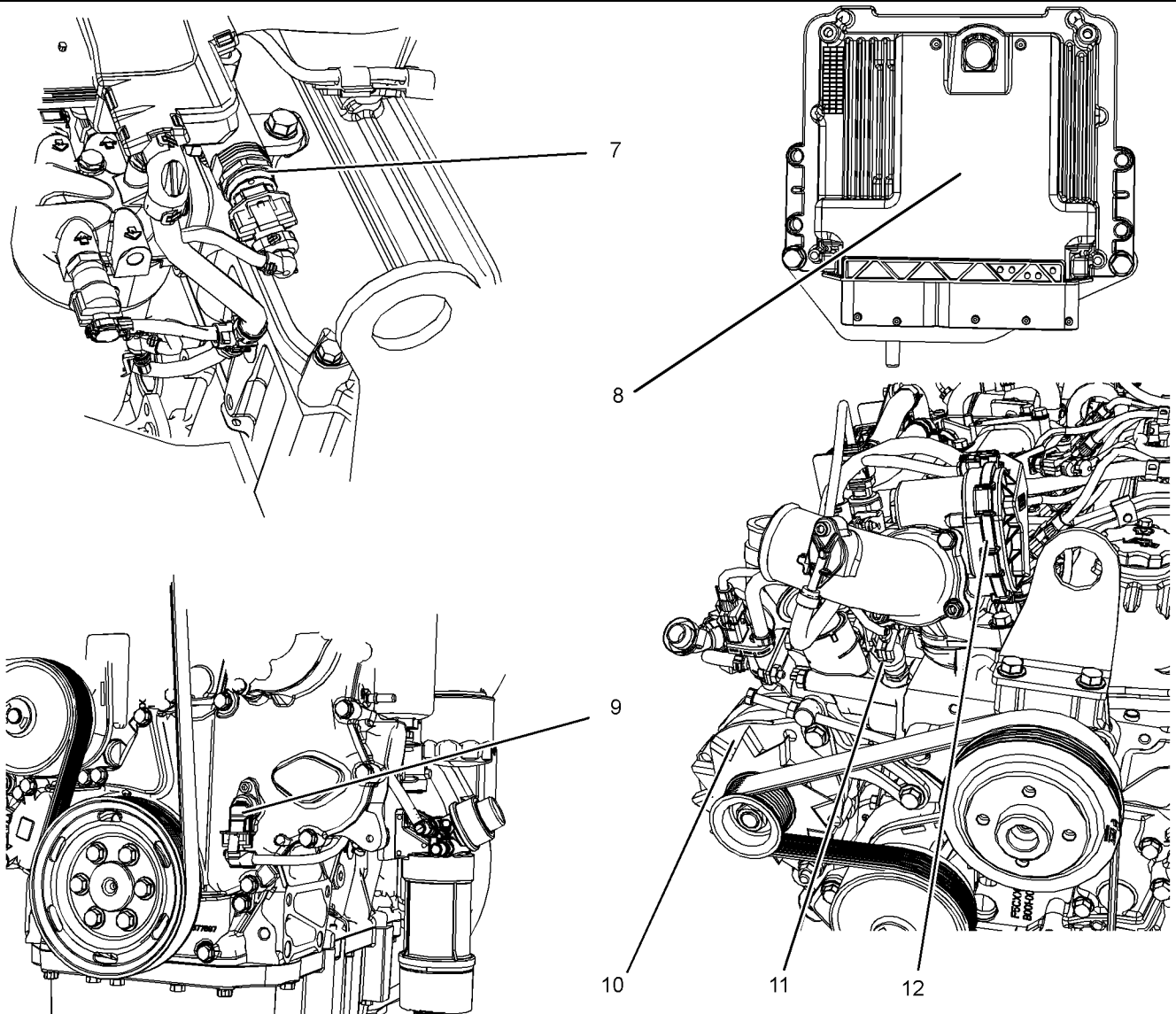

Illustration 33

g02529820

Typical example

(7) Fuel manifold (rail) pressure sensor
(8) Electronic control module

(9) Secondary speed/timing sensor
(camshaft position sensor)
(10) Alternator

(11) Coolant temperature sensor
(12) Intake throttle valve

Note: The location of item (8) the engine electronic control module will depend on the application.

Operation Section
Sensors and Electrical Components

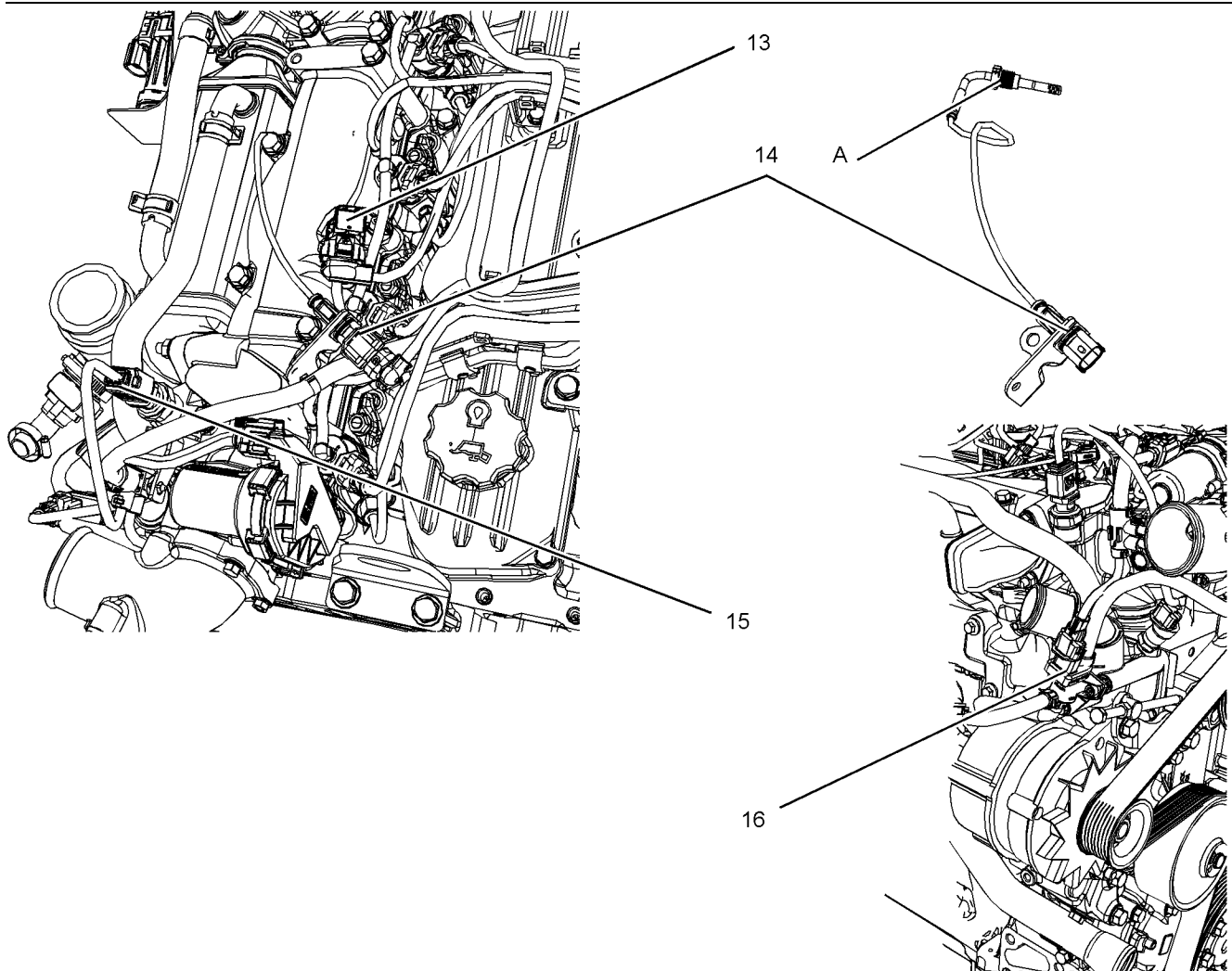

Illustration 34

g02529821

Typical example

(13) Inlet manifold pressure and temperature sensor.

(14) Exhaust temperature sensor connection
(A) Exhaust temperature sensor

(15) Exhaust pressure sensor
(16) Waste gate regulator

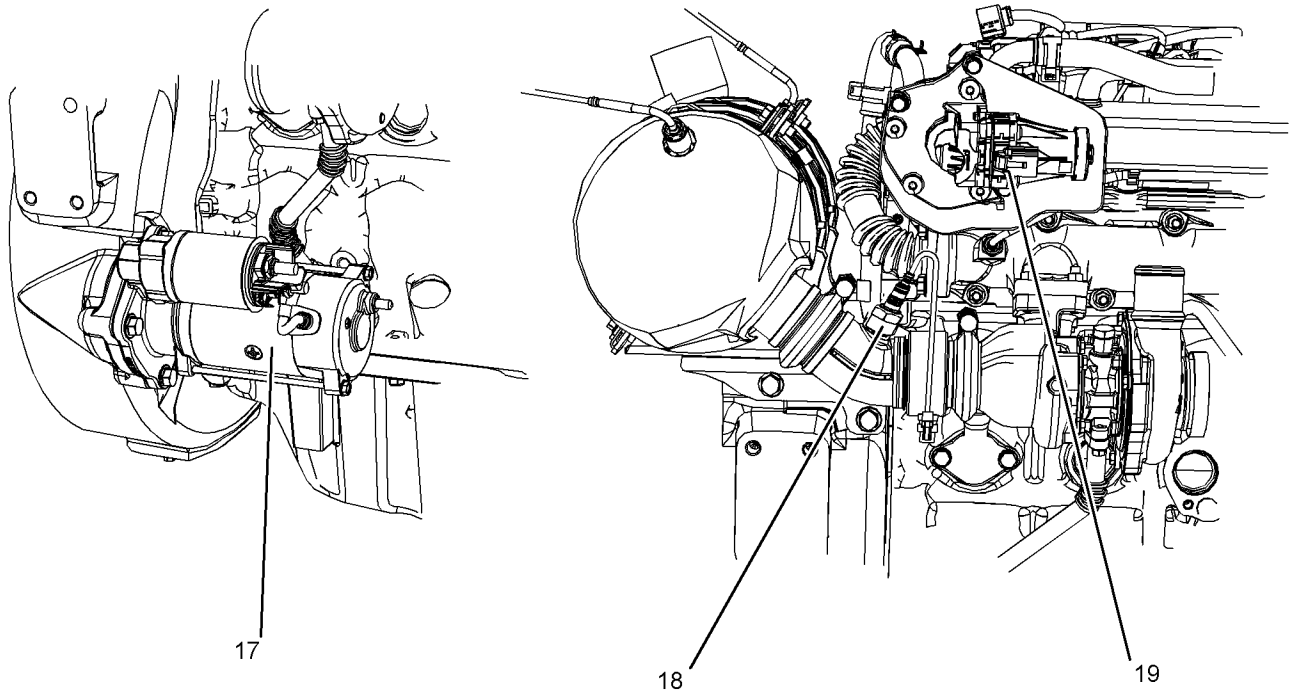

Illustration 35

g02530397

Typical example

(17) Starting motor

(18) Position for oxygen sensor

(19) NOx reduction control valve

Note: Some engines can have the air intake temperature sensor and the glow plug control unit supplied loose.

Separate Inlet Pressure and Inlet Temperature Views

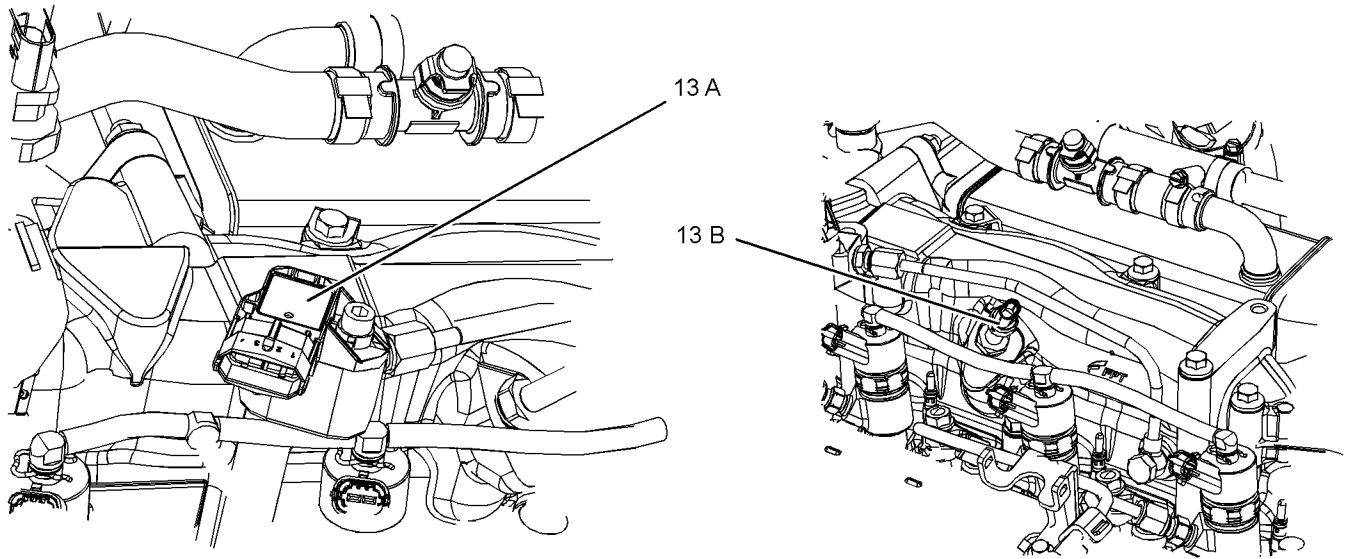

Illustration 36

g03373791

Typical example

(13 A) Intake manifold pressure sensor

(13 B) Intake manifold temperature sensor

Engine Option or Parts that are Supplied Loose

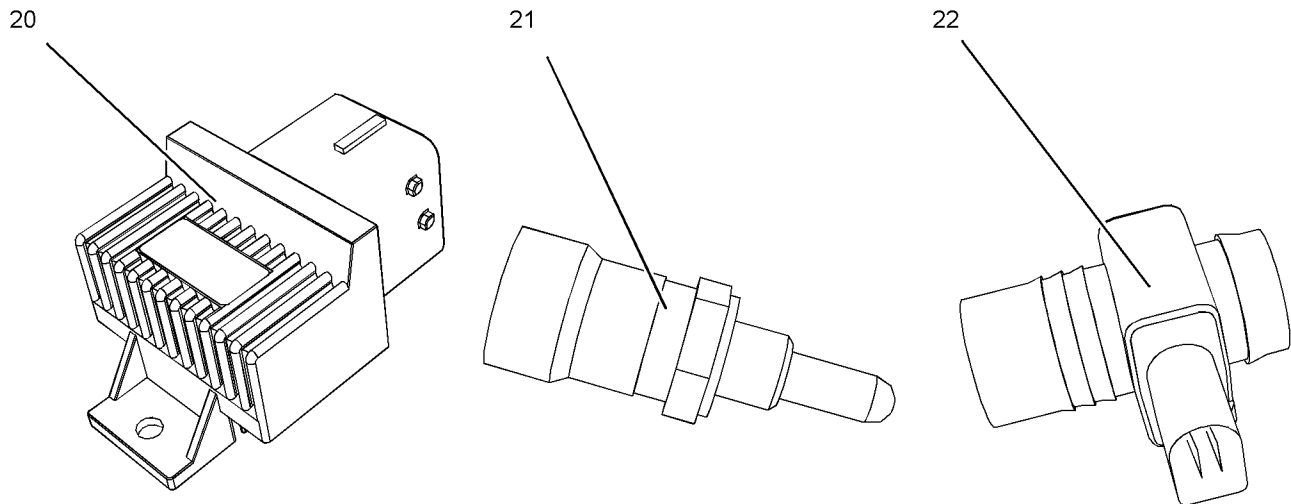

Illustration 37

g02821639

Typical example

(20) Glow plug control unit

(21) Inlet air temperature sensor

(22) Breather heater

Some engines can have a breather heater (22) for the crankcase breather installed.

i05325624

Sensors and Electrical Components (Aftertreatment)

SMCS Code: 1900; 7400

There are two types of aftertreatment that can be installed. The engine power will determine the type of aftertreatment that is installed.

Wall Flow Aftertreatment

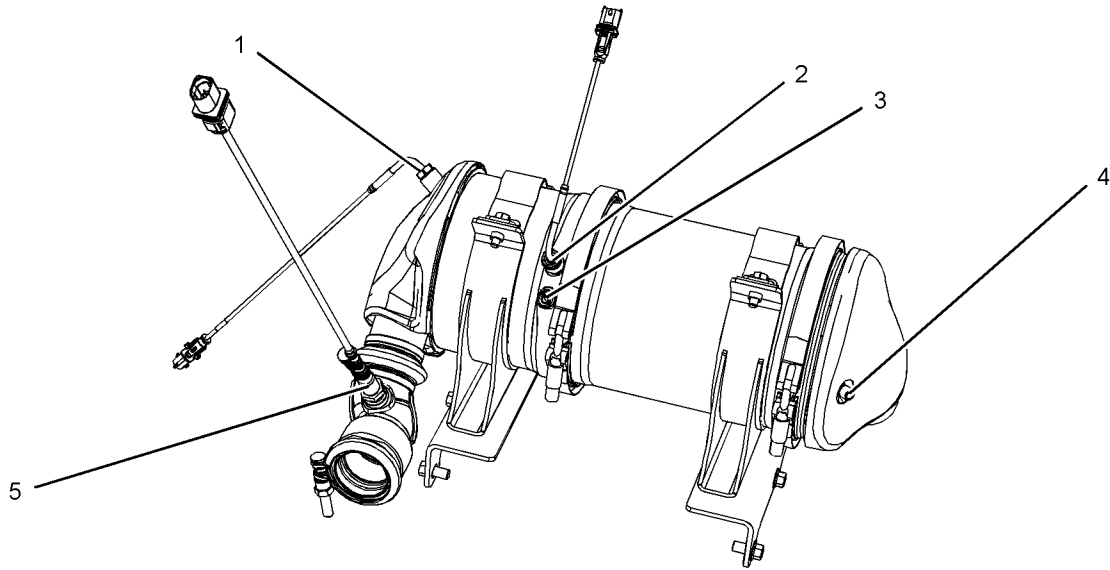

Illustration 38

g03373851

Typical example

- | | | |
|--|--|-------------------|
| (1) Diesel oxidation catalyst temperature sensor | (3) Inlet connection for the differential pressure sensor | (5) Oxygen sensor |
| (2) Diesel particulate filter (DPF) temperature sensor | (4) Outlet connection for the differential pressure sensor | |

Through Flow Aftertreatment

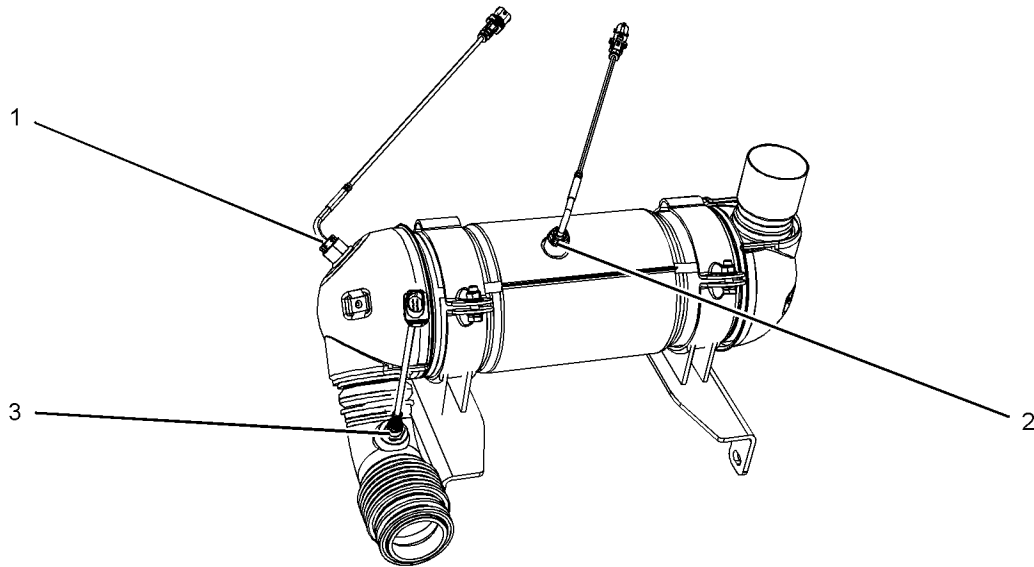

Illustration 39

g03373872

Typical example

- | | |
|--|----------------------------------|
| (1) Diesel oxidation catalyst (DOC) temperature sensor | (2) Temperature sensor after DOC |
| | (3) Oxygen sensor |

Differential Pressure sensor

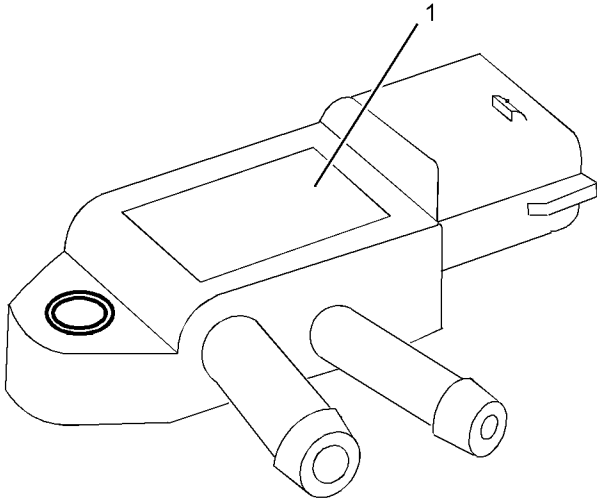

Illustration 40

g02477086

Typical example

(1) Differential pressure sensor

The location of the differential pressure sensor will depend on the application. The differential pressure is installed on the wall flow DPF. The through-flow DPF does not always require the sensor to be installed.

Engine Diagnostics

i04348749

Self-Diagnostics

i01796959

SMCS Code: 1000; 1900; 1901; 1902

Caterpillar Electronic Engines have the capability to perform a self-diagnostics test. When the system detects an active problem, a diagnostic lamp is activated. Diagnostic codes will be stored in permanent memory in the Electronic Control Module (ECM). The diagnostic codes can be retrieved by using Caterpillar electronic service tools.

Some installations have electronic displays that provide direct readouts of the engine diagnostic codes. Refer to the manual that is provided by the OEM for more information on retrieving engine diagnostic codes.

Active codes represent problems that currently exist. These problems should be investigated first.

Logged codes represent the following items:

- Intermittent problems
- Recorded events
- Performance history

The problems may have been repaired since the logging of the code. These codes do not indicate that a repair is needed. The codes are guides or signals when a situation exists. Codes may be helpful to troubleshoot problems.

When the problems have been corrected, the corresponding logged fault codes should be cleared.

i03554520

Diagnostic Lamp

SMCS Code: 1000; 1900; 1901; 1902; 7451

A diagnostic lamp is used to indicate the existence of an active fault. A fault diagnostic code will remain active until the problem is repaired. The diagnostic code may be retrieved by using the electronic service tool.

Fault Logging

SMCS Code: 1000; 1900; 1901; 1902

The system provides the capability of Fault Logging. When the Electronic Control Module (ECM) generates an active diagnostic code, the code will be logged in the memory of the ECM. The codes that have been logged by the ECM can be identified by the electronic service tool. The active codes that have been logged will be cleared when the fault has been rectified or the fault is no longer active.

i03554534

Engine Operation with Active Diagnostic Codes

SMCS Code: 1000; 1900; 1901; 1902

If a diagnostic lamp illuminates during normal engine operation, the system has identified a situation that is not within the specification. Use electronic service tools to check the active diagnostic codes.

Note: If the customer has selected "DERATE" and if there is a low oil pressure condition, the Electronic Control Module (ECM) will limit the engine power until the problem is corrected. If the oil pressure is within the normal range, the engine may be operated at the rated speed and load. However, maintenance should be performed as soon as possible.

The active diagnostic code should be investigated. The cause of the problem should be corrected as soon as possible. If the cause of the active diagnostic code is repaired and there is only one active diagnostic code, the diagnostic lamp will turn off.

Operation of the engine and performance of the engine can be limited as a result of the active diagnostic code that is generated. Acceleration rates may be significantly slower. Refer to the Troubleshooting Guide for more information on the relationship between these active diagnostic codes and engine performance.

i01902995

Engine Operation with Intermittent Diagnostic Codes

SMCS Code: 1000; 1900; 1901; 1902

If a diagnostic lamp illuminates during normal engine operation and the diagnostic lamp shuts off, an intermittent fault may have occurred. If a fault has occurred, the fault will be logged into the memory of the Electronic Control Module (ECM).

In most cases, it is not necessary to stop the engine because of an intermittent code. However, the operator should retrieve the logged fault codes and the operator should reference the appropriate information in order to identify the nature of the event. The operator should log any observation that could have caused the lamp to light.

- Low power
- Limits of the engine speed
- Excessive smoke, etc

This information can be useful to help troubleshoot the situation. The information can also be used for future reference. For more information on diagnostic codes, refer to the Troubleshooting Guide for this engine.

i05844821

Configuration Parameters

SMCS Code: 1000; 1900; 1901; 1902

The engine electronic control module (ECM) has two types of configuration parameters. The system configuration parameters and the customer specified parameters.

The electronic service tool is required in order to alter the configuration parameters.

System Configuration Parameters

System configuration parameters affect the emissions of the engine or the power of the engine. System configuration parameters are programmed at the factory. Normally, system configuration parameters would never require changing through the life of the engine. System configuration parameters must be reprogrammed if an ECM is replaced.

Customer Specified Parameters

Customer specified parameters allow the engine to be configured to the exact needs of the application.

The electronic service tool is required in order to alter the customer configuration parameters.

Customer parameters may be changed repeatedly as operational requirements change.

Table 2

Customer Specified Parameters	
Specified Parameters	Record
Low Idle Speed	

(continued)

Operation Section
Configuration Parameters

(Table 2, contd)

Throttle Position 1 Engine Speed	
Throttle Position 2 Engine Speed	
Throttle Position 3 Engine Speed	
Throttle Position 4 Engine Speed	
Engine Idle Shutdown Enable Status	
Engine Idle Shutdown Delay Status	
Throttle Lock Feature Installation Status	
Multi State Input Switch Enable Status	
Multi State Input Switch Control Purpose	
Multi Position Throttle Switch Initialization Enable Status	
Throttle Lock Engine Set Speed #1	
Throttle Lock Increment Speed Ramp Rate	
Throttle Lock Decrement Speed Ramp Rate	
Throttle Lock Engine Set Speed Increment	
Monitoring Mode Shutdowns	
Limp Home Desired Engine Speed	
Engine Acceleration Rate	
Engine Location	
High Exhaust System Temperature Indicator Installation Status	
Oil Pressure Lamp Installation Status	
Wait to Start Lamp Installation Status	
Warning Lamp Installation Status	
Shutdown Lamp Installation Status	
Starter Relay Installation Status	
Low Pressure Fuel Pump Installation Status	
Remote Torque Speed Control Enable Status	
Throttle Arbitration Method	
Manual Throttle Arbitration Precondition Check	
Throttle Enable Status	
Throttle #1 Initial Lower Position	
Throttle #1 Initial Upper Position	
Throttle #1 Idle Validation Switch Enable Status	
Throttle #1 Idle Validation Minimum Off Threshold	
Throttle #1 Idle Validation Maximum On Threshold	
Throttle #1 Lower Diagnostic Limit	
Throttle #1 Upper Diagnostic Limit	
Throttle #2 Initial Lower Position	

(continued)

(Table 2, contd)

Throttle #2 Initial Upper Position	
Throttle #2 Idle Validation Switch Enable Status	
Throttle #2 Idle Validation Minimum Off Threshold	
Throttle #2 Idle Validation Maximum On Threshold	
Throttle #2 Lower Diagnostic Limit	
Throttle #2 Upper Diagnostic Limit	
Engine Operation Mode #1 High Idle Speed	
Engine Operation Mode #1 High Idle Droop Percentage	
Engine Operation Mode #1 Throttle #1 Droop Percentage	
Engine Operation Mode #1 Throttle #2 Droop Percentage	
Engine Operation Mode #1 TSC1 Droop Percentage	
Engine Operation Mode #2 High Idle Speed	
Engine Operation Mode #2 High Idle Droop Percentage	
Engine Operation Mode #2 Throttle #1 Droop Percentage	
Engine Operation Mode #2 Throttle #2 Droop Percentage	
Engine Operation Mode #2 TSC1 Droop Percentage	
Engine Operation Mode #3 High Idle Droop Percentage	
Engine Operation Mode #3 High Idle Droop Percentage	
Engine Operation Mode #3 Throttle #1 Droop Percentage	
Engine Operation Mode #3 Throttle #2 Droop Percentage	
Engine Operation Mode #3 TSC1 Droop Percentage	
Engine Operation Mode #4 High Idle Speed	
Engine Operation Mode #4 High Idle Droop Percentage	
Engine Operation Mode #4 Throttle #1 Droop Percentage	
Engine Operation Mode #4 Throttle #2 Droop Percentage	
Engine Operation Mode #4 TSC1 Droop Percentage	

Engine Starting

i05365833

i03648917

Before Starting Engine

SMCS Code: 1000; 1400; 1450

Perform the required daily maintenance and other periodic maintenance before the engine is started. Inspect the engine compartment. This inspection can help prevent major repairs at a later date. Refer to the Operation and Maintenance Manual, "Maintenance Interval Schedule" for more information.

- Ensure that the engine has an adequate fuel supply.
- Open the fuel supply valve (if equipped).

NOTICE

All valves in the fuel return line must be open and fuel supply lines must be open. Damage to the fuel system can occur if fuel lines are closed with the engine in operation.

If the engine has not been started for several weeks, fuel may have drained from the fuel system. Air may have entered the filter housing. Also, when fuel filters have been changed, some air pockets will be trapped in the engine. In these instances, prime the fuel system. Refer to the Operation and Maintenance Manual, "Fuel System - Prime" for more information on priming the fuel system. Also, check that the fuel specification is correct and that the fuel condition is correct. Refer to the Operation and Maintenance Manual, "Fuel Recommendations".

WARNING

Engine exhaust contains products of combustion which may be harmful to your health. Always start and operate the engine in a well ventilated area and, if in an enclosed area, vent the exhaust to the outside.

- Do not start the engine or move any of the controls if there is a "DO NOT OPERATE" warning tag or similar warning tag attached to the start switch or to the controls.
- Reset all of the shutoffs or alarm components.
- Ensure that any driven equipment has been disengaged. Minimize electrical loads or remove any electrical loads.

Cold Weather Starting

SMCS Code: 1000; 1250; 1450; 1453; 1456; 1900

WARNING

Do not use aerosol types of starting aids such as ether. Such use could result in an explosion and personal injury.

Startability will be improved at temperatures below -18°C (0°F) from the use of a jacket water heater or extra battery capacity.

When Group 2 diesel fuel is used, the following items provide a means of minimizing starting problems and fuel problems in cold weather: Engine oil pan heaters, jacket water heaters, fuel heaters and fuel line insulation. For more information, refer to Commercial Diesel Engine Fluids Recommendations, SEBU6251.

Use the procedure that follows for cold weather starting.

Note: Do not adjust the engine speed control during start-up. The electronic control module (ECM) will control the engine speed during start-up.

1. Disengage any driven equipment.
2. Turn the keyswitch to the RUN position. Leave the keyswitch in the RUN position until the warning light for the glow plugs is extinguished.

NOTICE

Do not engage the starting motor when flywheel is turning. Do not start the engine under load.

If the engine fails to start within 30 seconds, release the starter switch or button and wait two minutes to allow the starting motor to cool before attempting to start the engine again.

3. When the warning light for the glow plugs is extinguished turn, the keyswitch to the START position in order to engage the electric starting motor and crank the engine.

Note: The operating period of the warning light for the glow plugs will change due to the temperature of the engine.

4. Allow the keyswitch to return to the RUN position after the engine starts.
5. Repeat step 2 through step 4 if the engine fails to start.

Note: After starting, the engine will be held at low speed. The time held at low speed will depend on ambient temperature and time since last run. The procedure is in order to allow the engine systems to stabilize. The engine should not be raced in order to speed up the warm-up process.

6. Allow the engine to idle for 3 to 5 minutes, or allow the engine to idle until the water temperature indicator begins to rise. When idling after the engine has started in cold weather, increase the engine rpm from 1000 to 1200 rpm. This operation will warm up the engine more quickly. Maintaining an elevated low idle speed for extended periods will be easier with the installation of a hand throttle. Allow the white smoke to disperse before proceeding with normal operation.
7. Operate the engine at low load until all systems reach operating temperature. Check the gauges during the warm-up period.

i05365826

Starting the Engine

SMCS Code: 1000; 1450

Note: Do not adjust the engine speed control during start-up. The electronic control module (ECM) will control the engine speed during start-up.

Starting the Engine

1. Disengage any equipment that is driven by the engine.
2. Turn the keyswitch to the first position power on. Check that the low oil pressure lamp is on solid. If the lamp is on solid, the engine start sequence can continue. If the lamp is flashing, and engine oil change is required. Refer to this Operation and Maintenance Manual, "Engine Oil and Filter - Change" for more information.
3. Turn the keyswitch to the RUN position. Leave the keyswitch in the RUN position until the warning light for the glow plugs is extinguished.

Note: During the key on, the indicator lamps will be illuminated for 2 seconds in order to check lamp operation. If any of the lamps do not illuminate, check the bulb. If the fault remains refer to Troubleshooting, "Indicator Lamp Circuit - Test".

4. When the warning light for the glow plugs is extinguished, turn the keyswitch to the START position in order to engage the electric starting motor and crank the engine.

Note: The operating period of the warning light for the glow plugs will change due to the temperature of the engine.

NOTICE

Do not engage the starting motor when flywheel is turning. Do not start the engine under load.

If the engine fails to start within 30 seconds, release the starter switch or button and wait two minutes to allow the starting motor to cool before attempting to start the engine again.

5. Allow the keyswitch to return to the RUN position after the engine starts. Ensure that all warning lamps are off.
6. Repeat step 2 through step 5 if the engine fails to start.
7. After starting, the engine will be held at low speed. The time held at low speed will depend on ambient temperature and time since last run. The procedure is in order to allow the engine systems to stabilize.
8. If the engine will not start, refer to Troubleshooting, "Engine Cranks but Does Not Start"

i03653722

Starting with Jump Start Cables

SMCS Code: 1000; 1401; 1402; 1900

WARNING

Improper jump start cable connections can cause an explosion resulting in personal injury.

Prevent sparks near the batteries. Sparks could cause vapors to explode. Do not allow jump start cable ends to contact each other or the engine.

If the installation is not equipped with a backup battery system, it may be necessary to start the engine from an external electrical source.

For information on troubleshooting the charging system, refer to Special Instruction, REHS0354, "Charging System Troubleshooting".

Many batteries which are considered unusable are still rechargeable. After jump starting, the alternator may not be able to fully recharge batteries that are severely discharged. The batteries must be charged to the proper voltage with a battery charger. For information on testing and charging, refer to the Special Instruction, SEHS7633, "Battery Test Procedure".

NOTICE

Using a battery source with the same voltage as the electric starting motor. Use **ONLY** equal voltage for jump starting. The use of higher voltage will damage the electrical system.

Do not reverse the battery cables. The alternator can be damaged. Attach ground cable last and remove first.

When using an external electrical source to start the engine, turn the generator set control switch to the "OFF" position. Turn all electrical accessories OFF before attaching the jump start cables.

Ensure that the main power switch is in the OFF position before attaching the jump start cables to the engine being started.

1. Turn the start switch on the stalled engine to the OFF position. Turn off all the engine's accessories.
2. Connect one positive end of the jump start cable to the positive cable terminal of the discharged battery. Connect the other positive end of the jump start cable to the positive cable terminal of the electrical source.
3. Connect one negative end of the jump start cable to the negative cable terminal of the electrical source. Connect the other negative end of the jump start cable to the engine block or to the chassis ground. This procedure helps to prevent potential sparks from igniting the combustible gases that are produced by some batteries.

Note: The engine ECM must be powered before the starting motor is operated or damage can occur.

4. Start the engine in the normal operating procedure. Refer to this Operation and Maintenance Manual, "Starting the Engine".
5. Immediately after the engine is started, disconnect the jump start cables in reverse order.

After jump starting, the alternator may not be able to fully recharge batteries that are severely discharged. The batteries must be replaced or charged to the proper voltage with a battery charger after the engine is stopped. Many batteries which are considered unusable are still rechargeable. Refer to Operation and Maintenance Manual, "Battery - Replace" and Testing and Adjusting Manual, "Battery - Test".

Refer to the Electrical Schematic for your engine. Consult your Caterpillar dealer for more information.

i06721570

After Starting Engine

SMCS Code: 1000

After starting, the engine will be held at low speed. The time held at low speed will depend on ambient temperature and time since last run. The procedure is to allow the engine systems to stabilize.

Note: In ambient temperatures from 0°C to 60°C (32°F to 140°F), the warm-up time is approximately 3 minutes. In temperatures below 0°C (32°F), additional warm-up time may be required.

When the engine idles during warm-up, observe the following conditions:

Do not check the high-pressure fuel lines with the engine or the starting motor in operation. If you inspect the engine in operation, always use the proper inspection procedure to avoid a fluid penetration hazard. Refer to Operation and Maintenance Manual, "General hazard Information".

- Check for any fluid or for any air leaks at idle rpm and at one-half full rpm (no load on the engine) before operating the engine under load.
- Allow the engine to idle for 3 to 5 minutes, or allow the engine to idle until the water temperature indicator begins to rise. Check all gauges during the warm-up period.
- Constant speed engines or constant power engines should be allowed to operate at low idle for 3 minutes before used at operational speed. If the low idle option is not available, then operate the engine at operational speed with no load for 2 minutes.

Note: Gauge readings should be observed and the data should be recorded frequently while the engine is operating. Comparing the data over time will help to determine normal readings for each gauge. Comparing data over time will also help detect abnormal operating developments. Significant changes in the readings should be investigated.

Engine Operation

i04653132

Engine Operation

SMCS Code: 1000

Proper operation and maintenance are key factors in obtaining the maximum life and economy of the engine. If the directions in the Operation and Maintenance Manual are followed, costs can be minimized and engine service life can be maximized.

The time that is needed for the engine to reach normal operating temperature can be less than the time taken for a walk-around inspection.

The engine can be operated at the rated rpm after the engine is started and after the engine reaches operating temperature. The engine will reach normal operating temperature sooner during a low engine speed (rpm) and during a low-power demand. This procedure is more effective than idling the engine at no load. The engine should reach operating temperature in a few minutes.

Avoid excess idling. Excessive idling causes carbon buildup, engine slobber and soot loading of the Diesel Particulate Filter (DPF). Excess idling can be harmful to the engine.

Gauge readings should be observed and the data should be recorded frequently while the engine is operating. Comparing the data over time will help to determine normal readings for each gauge. Comparing data over time will also help detect abnormal operating developments. Significant changes in the readings should be investigated.

System Check

During normal engine operation the Electronic Control Module (ECM) will elevate the fuel pressure to the injectors. This check will be at scheduled intervals of approximately 100 hours depending on the duty cycle of the engine. The check will be carried out automatically without the need of any input from the operator.

During the time of elevated fuel pressure, the operator may notice a change in the tone of the engine. The ECM will operate the check at low idle for approximately 5 minutes.

i04810817

Diesel Particulate Filter Regeneration

SMCS Code: 108F

Regeneration

Regeneration is the removal of soot from the Diesel Particulate Filter (DPF). There are two different types of DPF that can be installed. The through flow DPF and the wall flow DPF. Engines with a power output of 56kW and above will have the wall flow DPF installed. Engines with a power output below 56kW have the option to use both types of DPF.

In table 3 titled **Indicator Operation** the operator will find information on the regeneration indicators. The table informs the operator why an indicator is illuminated and what action should be taken.

Through Flow DPF

The through flow DPF uses passive regeneration in order to remove the soot from the DPF. Passive regeneration is a chemical reaction within the system. Normal operation of the engine creates enough heat for a chemical reaction in order to regenerate the DPF. The regeneration occurs automatically during normal engine operation.

This system uses an amount of active regeneration in order to ensure that soot cannot exit the DPF. The through flow DPF will not require manual cleaning.

For a typical view of the through flow DPF, refer to this Operation and Maintenance Manual, "Sensors and Electrical Components (Aftertreatment)"

Wall Flow DPF

The wall flow DPF uses passive regeneration and active regeneration in order to remove the soot from the DPF. The ash is trapped within the DPF and must be removed by a manual cleaning process. Refer to Operation and Maintenance Manual, "Diesel Particulate Filter- Clean".

For a typical view of the wall flow DPF, refer to this Operation and Maintenance Manual, “Sensors and Electrical Components (Aftertreatment)”

Regeneration Indicators

Five indicators can be affected by the DPF regeneration. these indicators are, Regeneration Active, DPF, Disable Regeneration, Amber, or Yellow Warning Indicator and Red Stop Indicator.



Regeneration Active – This indicator will illuminate during active regeneration. The indicator shows that elevated exhaust temperatures are possible. The indicator will be turned off when regeneration is complete.



DPF – This indicator provides a general indication of the soot load. The indicator is off when the soot load is normal.



Disable Regeneration – This indicator is illuminated whenever the disable switch is activated.

Modes of Regeneration

- Automatic regeneration
- Forced regeneration

Automatic regeneration – Automatic regeneration will occur when the level of soot reaches the trigger point that is set in the ECM. The engine can operate normally during an automatic regeneration.

Manual – A manual regeneration is initiated by pressing the regeneration switch. A forced regeneration can only be performed after the soot load has illuminated the DPF indicator. A forced regeneration will only be required if the automatic regeneration has not been completed. This situation can be due to either the disable switch being operated or the duty cycle of the engine.

Note: In some applications the engine safety interlocks will need to be in place before a forced regeneration can occur.

Regeneration Switch

Note: The regeneration switch is a three position switch. Some OEMs may use other means of activating a forced regeneration such as touch screen interfaces.



Force Regeneration – Press in the top of the switch for 2 seconds in order to begin regeneration.



Disable Regeneration – Press in the bottom of the switch for 2 seconds in order to disable regeneration. Press again in order to return to automatic mode.

Note: Turning the keyswitch to the OFF position will remove the disable regeneration input and return the engine to automatic mode of regeneration.

Note: The MIDDLE position of the regeneration switch is the default position for automatic regeneration.

Note: You may return to normal operation at any point during a regeneration.

Regeneration System Warning Indicators

Some applications may also have an audible warning installed.

Table 3

Indicator Operation					
During passive regeneration no indicator will be illuminated					
Aftertreatment Indicator	Aftertreatment Indicator State	Warning Indicator	Warning Indicator State	Description	Action Required
Regeneration Active indicator	On Solid	None	None	Regeneration is activated. The indicator will stay illuminated during regeneration.	None
-					
DPF Indicator	On Solid	None	None	The indicator provides a general indication of the soot load. The indicator is off when the soot load is normal.	A regeneration is required. In automatic mode the ECM will decide when to allow the active regeneration. If the DPF indicator stays illuminated allow a manual regeneration without interruption. An uninterrupted active regeneration will reset the DPF indicator.
-					
DPF Indicator	On Solid	Amber indicator	Flashing	The indicator indicates that the soot load has increased. The engine will derate.	A manual regeneration is required. Perform a manual regeneration, or a service regeneration will be required.
-					
DPF Indicator	On Solid	Amber indicator	Flashing	The flashing warning indicator and red stop indicator indicates that the engine has continued to be operated while a regeneration is required. The engine will be derated and the engine should be shut down immediately.	Once the engine enters into shutdown mode, you must contact your Cat dealer. Your dealer will need to perform a service level regeneration. The DPF may need to be replaced.
-	-	Red indicator (STOP)	On Solid		

Note: Amber or yellow warning indicator can be used as a diagnostic lamp. For more information refer to this Operation and Maintenance Manual, "Diagnostic Lamp".

Regeneration Operation

Regeneration will require the following conditions:

Automatic Regeneration

In order for an automatic regeneration to take place the engine must be at operating temperature.

Turning the keyswitch to the OFF position during a regeneration will stop the regeneration. An interrupted regeneration will not remove the soot from the DPF and will waste fuel.

Wall Flow DPF Only

The engine Revs Per Minute (RPM) must be above 1200 RPM for the regeneration to start. Normal operation can continue. During an automatic regeneration the minimum idle speed will be controlled to 950 RPM.

Manual Regeneration

The DPF indicator must be illuminated. Where applicable, safety interlock for your application must be engaged before a manual regeneration can occur, refer to your OEM for more information. No throttle inputs are required, the ECM will control the engine RPM. Press the force regeneration switch for 2 seconds. Do not operate the application during the manual regeneration.

Service Regeneration

The electronic service tool will be required in order to perform a force regeneration. Contact your Cat dealer.

i01646335

Engaging the Driven Equipment

SMCS Code: 1000

1. Operate the engine at one-half of the rated rpm, when possible.
2. Engage the driven equipment without a load on the equipment, when possible.

Interrupted starts put excessive stress on the drive train. Interrupted starts also waste fuel. To get the driven equipment in motion, engage the clutch smoothly with no load on the equipment. This method should produce a start that is smooth and easy. The engine rpm should not increase and the clutch should not slip.

3. Ensure that the ranges of the gauges are normal when the engine is operating at one-half of the rated rpm. Ensure that all gauges operate properly.
4. Increase the engine rpm to the rated rpm. Always increase the engine rpm to the rated rpm before the load is applied.
5. Apply the load. Begin operating the engine at low load. Check the gauges and equipment for proper operation. After normal oil pressure is reached and the temperature gauge begins to move, the engine may be operated at full load. Check the gauges and equipment frequently when the engine is operated under load.

Extended operation at low idle or at reduced load may cause increased oil consumption and carbon buildup in the cylinders. This carbon buildup results in a loss of power and/or poor performance.

i04018250

Fuel Conservation Practices

SMCS Code: 1000; 1250

The efficiency of the engine can affect the fuel economy. Caterpillar's design and technology in manufacturing provides maximum fuel efficiency in all applications. Follow the recommended procedures in order to attain optimum performance for the life of the engine.

- Avoid spilling fuel.

Fuel expands when the fuel is warmed up. The fuel may overflow from the fuel tank. Inspect fuel lines for leaks. Repair the fuel lines, as needed.

- Be aware of the properties of the different fuels. Use only the recommended fuels. Refer to the Operations and Maintenance Manual, "Fuel Recommendations" for further information.

- Avoid unnecessary idling.

Shut off the engine rather than idle for long periods of time.

- Observe the service indicator frequently. Keep the air cleaner elements clean.
- Ensure that the turbocharger is operating correctly. For more information refer to this Operation and Maintenance Manual, "Turbocharger - Inspect".
- Maintain a good electrical system.

One faulty battery cell will overwork the alternator. This fault will consume excess power and excess fuel.

- The belt should be in good condition. Refer to the Systems Operation, Testing and Adjusting, "V - Belt Test" for further information.
- Ensure that all of the connections of the hoses are tight. The connections should not leak.
- Ensure that the driven equipment is in good working order.
- Cold engines consume excess fuel. Utilize heat from the jacket water system and the exhaust system, when possible. Keep cooling system components clean and keep cooling system components in good repair. Never operate the engine without water temperature regulators. All of these items will help maintain operating temperatures.

Cold Weather Operation

i06708361

Cold Weather Operation

SMCS Code: 1000; 1250

Caterpillar Diesel Engines can operate effectively in cold weather. During cold weather, the starting and the operation of the diesel engine depends on the following items:

- The type of fuel that is used
- The viscosity of the engine oil
- The operation of the glow plugs
- Optional Cold starting aid
- Battery condition

Refer to Special Publication, SEBU5898, "Cold-Weather Recommendations for Caterpillar Machines".

This section will cover the following information:

- Potential problems that are caused by cold-weather operation
- Suggest steps which can be taken to minimize starting problems and operating problems when the ambient air temperature is between "0°C to -40 °C (32°F to -40 °F)".

The operation and maintenance of an engine in freezing temperatures is complex . This complexity is because of the following conditions:

- Weather conditions
- Engine applications

Recommendations from your Cat dealer are based on past proven practices. The information that is contained in this section provides guidelines for cold-weather operation.

Hints for Cold-Weather Operation

- If the engine will start, operate the engine until a minimum operating temperature of 80° C (176° F) is achieved. Achieving operating temperature will help prevent the intake valves and exhaust valves from sticking.
- The cooling system and the lubrication system for the engine do not lose heat immediately upon shutdown. This means that an engine can be shut down for a period and the engine can still start readily.

- Install the correct specification of engine lubricant before the beginning of cold weather.
- Check all rubber parts (hoses, fan drive belts) weekly.
- Check all electrical wiring and connections for any fraying or damaged insulation.
- Keep all batteries fully charged and warm.
- Fill the fuel tank at the end of each shift.
- Drain the water from the fuel system. Refer to this Operation and Maintenance Manual, "Fuel System Primary Filter/Water Separator - Drain".
- Check the air cleaners and the air intake daily. Check the air intake more often when you operate in snow.
- Ensure that the glow plugs are in working order. Refer to Troubleshooting, "Glow Plug Starting Aid - Test".

WARNING

Personal injury or property damage can result from alcohol or starting fluids.

Alcohol or starting fluids are highly flammable and toxic and if improperly stored could result in injury or property damage.

WARNING

Do not use aerosol types of starting aids such as ether. Such use could result in an explosion and personal injury.

- For jump starting with cables in cold weather, refer to the Operation and Maintenance Manual, "Starting with Jump-Start Cables." for instructions.

Viscosity of the Engine Lubrication Oil

Correct engine oil viscosity is essential. Oil viscosity affects the amount of torque that is needed to crank the engine. Refer to this Operation and Maintenance Manual, "Fluid Recommendations" for the recommended viscosity of oil.

Recommendations for the Coolant

Provide cooling system protection for the lowest expected outside temperature. Refer to this Operation and Maintenance Manual, "Fluid Recommendations" for the recommended coolant mixture.

In cold weather, check the coolant often for the correct glycol concentration to ensure adequate freeze protection.

Engine Block Heaters

Engine block heaters (if equipped) heat the engine jacket water that surrounds the combustion chambers. This heat provides the following functions:

- Startability is improved.
- Warm up time is reduced.

An electric block heater can be activated once the engine is stopped. A block heater can be 110V dc or 240V dc. The output can be 750/1000W. Consult your Cat dealer for more information.

Idling the Engine

After starting the engine, the engine speed will be held at low speed. The time held at low speed will depend on ambient temperature and time since last run. The procedure is to allow the engine systems to stabilize. When idling after the engine is started in cold weather, increase the engine rpm from 1000 rpm to 1200 rpm. This increase in RPM will warm up the engine more quickly. Maintaining an elevated low idle speed for extended periods will be easier with the installation of a hand throttle. The engine should not be "raced" to speed up the warm up process.

While the engine is idling, the application of a light load (parasitic load) will help in achieving the minimum operating temperature. The minimum operating temperature is 80° C (176° F).

Recommendations for Coolant Warm Up

Warm up an engine that has cooled below normal operating temperatures due to inactivity. This procedure should be performed before the engine is returned to full operation. During operation in very cold temperature conditions, damage to engine valve mechanisms can result from engine operation for short intervals. This damage can happen if the engine is started and the engine is stopped many times without being operated to warm up completely.

When the engine is operated below normal operating temperatures, fuel and oil are not completely burned in the combustion chamber. This fuel and oil causes soft carbon deposits to form on the valve stems. Generally, the deposits do not cause problems and the deposits are burned off during operation at normal engine operating temperatures.

When the engine is started and the engine is stopped many times without being operated to warm up completely, the carbon deposits become thicker. This carbon can cause the following problems:

- Free operation of the valves is prevented.
- Valves become stuck.
- Pushrods may become bent.
- Other damage to valve train components can result.

For this reason, when the engine is started, the engine must be operated until the coolant temperature is 80° C (176° F) minimum. Carbon deposit on the valve stems will be kept at a minimum and the free operation of the valves and the valve components will be maintained.

The engine must be thoroughly warmed to keep other engine parts in better condition. Also, the service life of the engine will be generally extended. Lubrication will be improved. There will be less acid and less sludge in the oil. This improvement will provide longer service life for the engine bearings, the piston rings, and other parts. However, limit unnecessary idle time to 10 minutes to reduce wear and unnecessary fuel consumption.

The Water Temperature Regulator and Insulated Heater Lines

The engine is equipped with a water temperature regulator. When the engine coolant is below the correct operating temperature, jacket water circulates through the engine cylinder block and into the engine cylinder head. The coolant then returns to the cylinder block via an internal passage that bypasses the valve of the coolant temperature regulator. This system ensures that coolant flows around the engine under cold operating conditions. The water temperature regulator begins to open when the engine jacket water has reached the correct minimum operating temperature. As the jacket water coolant temperature rises above the minimum operating temperature the water temperature regulator opens further allowing more coolant through the radiator to dissipate excess heat.

The progressive opening of the water temperature regulator operates the progressive closing of the bypass passage between the cylinder block and head. This process ensures maximum coolant flow to the radiator to achieve maximum heat dissipation.

Note: Do not restrict the air flow. Restriction to the air flow can damage the fuel system. Caterpillar strongly discourages the use of all air flow restriction devices such as radiator shutters. Restriction of the air flow can result in the following: high exhaust temperatures, power loss, excessive fan usage, and reduction in fuel economy.

A cab heater is beneficial in very cold weather. The feed from the engine and the return lines from the cab should be insulated to reduce heat loss to the outside air.

Insulating the Air Inlet and Engine Compartment

i05264084

When temperatures below -18°C (-0.4°F) will be frequently encountered, an air cleaner inlet that is located in the engine compartment may be specified. An air cleaner that is located in the engine compartment may also minimize the entry of snow into the air cleaner. Also, heat that is rejected by the engine helps to warm the intake air.

Extra heat can be retained around the engine by insulating the engine compartment.

Recommendation for Crankcase Breather Protection

Crankcase ventilation gases can contain a large quantity of water vapor. This water vapor can freeze in cold ambient conditions and can plug or damage the crankcase ventilation system.

The breather heater or other breather thermal protection is important and any OEM equipment must be operational to prevent the risk of breather freezing for operation below -5°C (23°F).

i05966861

Radiator Restrictions

SMCS Code: 1353; 1396

Caterpillar discourages the use of airflow restriction devices that are mounted in front of radiators. Airflow restriction can cause the following conditions:

- High exhaust temperatures
- Power loss
- Excessive fan usage
- Reduction in fuel economy

Reducing air flow over components will also affect under hood temperatures. Reducing air flow can increase surface temperatures during an aftertreatment regeneration and could affect component reliability.

Reducing air flow can increase surface temperatures during an aftertreatment regeneration and could affect component reliability.

If an airflow restriction device must be used, the device should have a permanent opening directly in line with the fan hub. The device must have a minimum opening dimension of at least 770 cm^2 (120 in^2).

A centered opening that is directly in line with the fan hub is specified in order to prevent an interrupted airflow on the fan blades. Interrupted airflow on the fan blades could cause a fan failure.

Fuel and the Effect from Cold Weather

SMCS Code: 1000; 1250; 1280

The following fuels are the grades that are available for Cat engines:

- No. 1
- No. 2
- Blend of No. 1 and No. 2

No. 2 diesel fuel is the most commonly used fuel. Either No. 1 diesel fuel or a blend of No. 1 and No. 2 is best suited for cold-weather operation.

Quantities of No. 1 diesel fuel are limited. No. 1 diesel fuels are usually available during the months of the winter in the colder climates. During cold-weather operation, if No. 1 diesel fuel is not available, use No. 2 diesel fuel, if necessary.

There are three major differences between No. 1 and No. 2 diesel fuel. No. 1 diesel fuel has the following properties:

- Lower cloud point
- Lower pour point
- Lower rating of kJ (BTU) per unit volume of fuel

When No. 1 diesel fuel is used, a decrease in power and in fuel efficiency may be noticed. Other operating effects should not be experienced.

The cloud point is the temperature when a cloud of wax crystals begins to form in the fuel. These crystals can cause the fuel filters to plug. The pour point is the temperature when diesel fuel will thicken. The diesel fuel becomes more resistant to flow through fuel pumps and through fuel lines.

Be aware of these values when diesel fuel is purchased. Anticipate the average ambient temperature of the area. Engines that are fueled in one climate may not operate well if the engines are moved to another climate. Problems can result due to changes in temperature.

Before troubleshooting for low power or for poor performance in the winter, check the type of fuel that is being used.

When No. 2 diesel fuel is used the following components provide a means of minimizing problems in cold weather:

- Starting aids
- Engine oil pan heaters

- Engine coolant heaters
- Fuel heaters
- Fuel line insulation

For more information on cold-weather operation, see Special Publication, SEBU5898, "Cold Weather Recommendations".

i05400921

Fuel Related Components in Cold Weather

SMCS Code: 1000; 1250; 1280

Fuel Tanks

Condensation can form in partially filled fuel tanks. Top off the fuel tanks after you operate the engine.

Fuel tanks should contain some provision for draining water and sediment from the bottom of the tanks. Some fuel tanks use supply pipes that allow water and sediment to settle below the end of the fuel supply pipe.

Some fuel tanks use supply lines that take fuel directly from the bottom of the tank. If the engine is equipped with this system, regular maintenance of the fuel system filter is important.

Drain the water and sediment from any fuel storage tank at the following intervals: weekly, service intervals and refueling of the fuel tank. This procedure will help prevent water and/or sediment from being pumped from the fuel storage tank and into the engine fuel tank.

Fuel Filters

After you change the fuel filters, always prime the fuel system in order to remove air bubbles from the fuel system. Refer to the Operation and Maintenance Manual in the Maintenance Section for more information on priming the fuel system.

The micron rating and the location of a primary fuel filter is important in cold-weather operation. The primary fuel filter and the fuel supply line are the most common components that are affected by cold fuel.

NOTICE

In order to maximize fuel system life and prevent premature wear out from abrasive particles in the fuel, a four micron[c] absolute high efficiency fuel filter is required for all Caterpillar Electronic Unit Injectors. Caterpillar High Efficiency Fuel Filters meet these requirements. Consult your Cat dealer for the proper part numbers.

Fuel Heaters

Fuel heaters help to prevent fuel filters from plugging in cold weather due to waxing. A fuel heater should be installed in the fuel system before the primary fuel filter.

For further information on fuel heaters, consult your Cat dealer.

Engine Stopping

i04535875

Stopping the Engine

SMCS Code: 1000

NOTICE

Stopping the engine immediately after it has been working under load, can result in overheating and accelerated wear of the engine components.

Avoid accelerating the engine prior to shutting it down.

Avoiding hot engine shutdowns will maximize turbo-charger shaft and bearing life.

Note: Individual applications will have different control systems. Ensure that the shutoff procedures are understood. Use the following general guidelines in order to stop the engine.

1. Remove the load from the engine. Reduce the engine speed (rpm) to low idle. Allow the engine to idle for 5 minutes in order to cool the engine.
2. Stop the engine after the cool down period according to the shutoff system on the engine and turn the ignition key switch to the OFF position. If necessary, refer to the instructions that are provided by the OEM.
3. Wait 60 seconds before the battery disconnect switch is turned off. The engine ECM required power after the keyswitch is turned off.

i03554860

Emergency Stopping

SMCS Code: 1000; 7418

NOTICE

Emergency shutoff controls are for EMERGENCY use ONLY. DO NOT use emergency shutoff devices or controls for normal stopping procedure.

Ensure that any components for the external system that support the engine operation are secured after the engine is stopped.

Emergency Stop Button

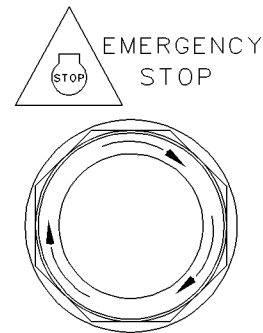

Illustration 41

g00104303

Typical emergency stop button

The emergency stop button is in the OUT position for normal engine operation. Push the emergency stop button. The engine will not start when the button is locked. Turn the button clockwise in order to reset.

Refer to Operation and Maintenance Manual, "Features and Controls" for the location and the operation of the emergency stop button.

i05784249

After Stopping Engine

SMCS Code: 1000

Note: Before you check the engine oil, do not operate the engine for at least 10 minutes. This period will allow the engine oil to return to the oil pan.

WARNING

Contact with high pressure fuel may cause fluid penetration and burn hazards. High pressure fuel spray may cause a fire hazard. Failure to follow these inspection, maintenance and service instructions may cause personal injury or death.

- After the engine has stopped, you must wait for 10 minutes in order to allow the fuel pressure to be purged from the high-pressure fuel lines before any service or repair is performed on the engine fuel lines. The 10 minute wait will also allow static charge to dissipate from the low-pressure fuel system. If necessary, perform minor adjustments. Repair any leaks from the low-pressure fuel system and from the cooling, lubrication, or air systems. Replace any high-pressure fuel line that has leaked. Refer to Disassembly and assembly Manual, "Fuel Injection Lines - Install".

Operation Section
After Stopping Engine

- Check the crankcase oil level. Maintain the oil level between the “MIN” mark and the “MAX” mark on the engine oil level gauge.
- If the engine is equipped with a service hour meter, note the reading. Perform the maintenance that is in the Operation and Maintenance Manual, “Maintenance Interval Schedule”.
- Fill the fuel tank, in order to help prevent accumulation of moisture in the fuel. Do not overfill the fuel tank.

NOTICE

Only use antifreeze/coolant mixtures recommended in this Operation and Maintenance Manual, “Refill Capacities and Recommendations” topic or in this Operation and Maintenance Manual, “Fluid Recommendations” topic. Failure to do so can cause engine damage.

 **WARNING**

Pressurized System: Hot coolant can cause serious burns. To open the cooling system filler cap, stop the engine and wait until the cooling system components are cool. Loosen the cooling system pressure cap slowly in order to relieve the pressure.

- Allow the engine to cool. Check the coolant level.
- Check the coolant for correct antifreeze protection and the correct corrosion protection. Add the correct coolant/water mixture, if necessary.
- Perform all required periodic maintenance on all driven equipment. This maintenance is outlined in the instructions from the OEM.

Maintenance Section

Refill Capacities

i05325415

Refill Capacities

SMCS Code: 1000; 1348; 1395; 7560

Lubrication System

The refill capacities for the engine crankcase reflect the approximate capacity of the crankcase or sump plus standard oil filters. Auxiliary oil filter systems will require additional oil. Refer to the OEM specifications for the capacity of the auxiliary oil filter. Refer to the Operation and Maintenance Manual, "Maintenance Section" for more information on Lubricant Specifications.

Table 4

Engine Refill Capacities		
Compartment or System	Minimum	Maximum
Crankcase Oil Sump ⁽¹⁾	6 L (1.6 US gal)	8.5 L (2.2 US gal)

⁽¹⁾ These values are the approximate capacities for the crankcase oil sump (aluminum) which includes the standard factory installed oil filters. Engines with auxiliary oil filters will require additional oil. Refer to the OEM specifications for the capacity of the auxiliary oil filter. The design of the oil pan can change the oil capacity of the oil pan.

Cooling System

Refer to the OEM specifications for the External System capacity. This capacity information will be needed in order to determine the amount of coolant/antifreeze that is required for the Total Cooling System.

Table 5

Engine Refill Capacities	
Compartment or System	Liters
Engine Only	6 L (1.6 US gal)
External System Per OEM ⁽¹⁾	

(continued)

(Table 5, contd)

⁽¹⁾ The External System includes a radiator or an expansion tank with the following components: heat exchanger and piping. Refer to the OEM specifications. Enter the value for the capacity of the External System in this row.

i05297874

Fluid Recommendations

SMCS Code: 1280; 1348; 1395; 7560

Engine Oil

NOTICE

These recommendations are subject to change without notice. Contact your local Cat dealer for the most up-to-date fluids recommendations.

- EMA _____ Engine Manufacturers Association
- API _____ American Petroleum Institute
- SAE _____ Society Of Automotive Engineers Inc.
- DEO-ULS _____ Diesel Engine Oil-Ultra Low Sulfur

Cat DEO-ULS

Cat DEO-ULS is developed and tested in order to provide superior protection and life for your Caterpillar engines.

- Better Detergents
- Advanced Additive Package
- Enhanced Dispersants
- Improved Protection from Thermal breakdown and Oxidation Breakdown

Due to significant variations in the quality and in the performance of commercially available oils, Caterpillar makes the following recommendations:

- **Cat DEO-ULS (SAE 10W-30)**
- **Cat DEO-ULS (SAE 15W-40)**

Cat DEO-ULS Multigrade oil is available in various viscosity grades that include SAE 10W-30 and SAE 15W-40. To choose the correct viscosity grade for the ambient temperature, see illustration 42. Multigrade oils provide the correct viscosity for a broad range of operating temperatures. Multigrade oils are also effective in maintaining low oil consumption and low levels of piston deposits.

Consult your Cat dealer for part numbers and for available sizes of containers.

Note: Cat DEO-ULS in SAE 15W-40 passes the following proprietary tests: sticking of the piston ring, oil control tests, wear tests and soot tests. Proprietary tests help ensure that Caterpillar multigrade oil provides superior performance in Caterpillar Diesel Engines. In addition, Cat DEO-ULS Multigrade oil exceeds many of the performance requirements of other manufacturers of diesel engines. Therefore, this oil is an excellent choice for many mixed fleets. **True high performance oil is produced with a combination of the following factors: industry standard tests, proprietary tests, field tests and prior experience with similar formulations. The design and the development of Caterpillar lubricants that are both high performance and high quality are based on these factors.**

Commercial Oils

Note: Non-Caterpillar commercial oils are second choice oils.

NOTICE

Caterpillar require the use of the following specification of engine oil. Failure to use the appropriate specification of engine oil will reduce the life of your engine. Failure to use the correct specification of engine will also reduce the life and the effectiveness of your aftertreatment system.

Table 6

API Classifications for the Industrial Engine
Oil Specification
ECF-3 CJ-4 AECA E9

NOTICE

Failure to follow these oil recommendations can cause shortened engine service life due to deposits and/or excessive wear.

Note: Refer to Special Publication, SEBU6251, "Caterpillar Commercial Diesel Engine Fluids Recommendations" for additional information that relates to lubrication for your engine.

Lubricant Viscosity Recommendations

The proper SAE viscosity grade of oil is determined by the minimum ambient temperature during cold engine start-up, and the maximum ambient temperature during engine operation.

Refer to illustration 42 (minimum temperature) in order to determine the required oil viscosity for starting a cold engine.

Refer to illustration 42 (maximum temperature) in order to select the oil viscosity for engine operation at the highest ambient temperature that is anticipated.

Note: Generally, use the highest oil viscosity that is available to meet the requirement for the temperature at start-up.

If ambient temperature conditions at engine start-up require the use of multigrade SAE 0W oil, SAE 0W-40 viscosity grade is preferred over SAE 0W-20 or SAE 0W-30

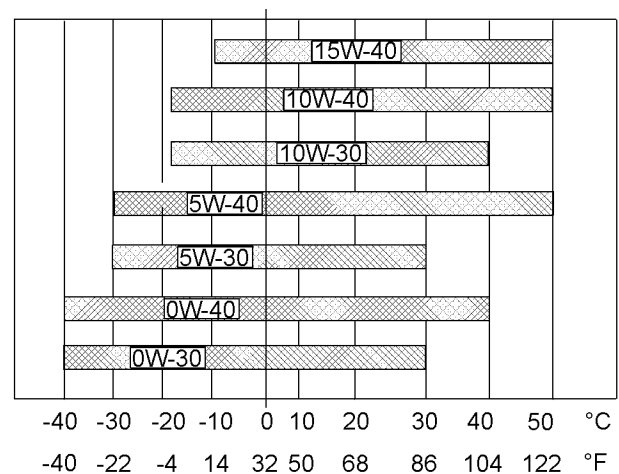

Illustration 42

g03363756

Supplemental heat is recommended for cold soaked starts below the minimum ambient temperature. Supplemental heat may be required for cold soaked starts that are above the minimum temperature that is stated, depending on the parasitic load and other factors. Cold soaked starts occur when the engine has not been operated for a period of time. This period will allow the oil to become more viscous due to cooler ambient temperatures.

S·O·S Oil Analysis

Caterpillar has developed a tool for maintenance management that evaluates oil degradation and the tool also detects the early signs of wear on internal components. The Caterpillar tool for oil analysis is called S·O·S Oil Analysis and the tool is part of the S·O·S Services program. S·O·S Oil Analysis divides oil analysis into three categories:

- Wear Analysis
- Oil condition
- Additional tests

The wear analysis monitors metal particles, some oil additives, and some contaminants.

Oil condition uses infrared (IR) analysis to evaluate the chemistry of the oil. Infrared analysis is also used to detect certain types of contamination.

Additional tests are used to measure contamination levels from water, fuel, or coolant. Oil viscosity and corrosion protection can be evaluated, as needed.

Refer to Special Publication, SEBU6251, "Caterpillar Commercial Diesel Engine Fluids Recommendations" or contact your local Cat dealer for additional information concerning the S·O·S Oil Analysis program.

Lubricating Grease

Caterpillar provides a range of moderate greases to extremely high performance greases in order to service the entire line of Caterpillar products that operate throughout the wide variety of climates. You will always be able to find a grease that will meet your machines requirements for a certain application. Caterpillar grease products often exceed Caterpillar specifications.

Before selecting a grease products for any application, the performance requirements must be determined. Consult the grease recommendations that are made by the OEM for the equipment when the equipment is operated in the expected conditions. Then, consult with your Cat dealer for a list of greases and the following related characteristics.

- Performance specifications
- Available sizes of containers
- Part numbers

Always choose a grease that meets the recommendations that are specified by the equipment manufacturer for the application, or choose a grease that exceeds the recommendations that are specified by the equipment manufacturer for the application.

If necessary, to choose a single grease for use on all of the equipment at one site, always choose a grease that meets the requirements of the most demanding application. A product that barely meets the minimum performance requirements will shorten the life of the part. Use the grease that yields the least total operating cost. Base this cost on an analysis that includes the costs of the parts, the labor, the downtime, and the cost of the grease that is used.

Some greases are not chemically compatible. Consult your supplier in order to determine if two or more greases are compatible.

Purge the grease from a joint at the following times:

- Switching from one grease to another grease
- Switching from one supplier to another supplier

Note: All Caterpillar brand name greases are compatible with each other.

Note: Refer to Special Publication, SEBU6251, "Caterpillar Commercial Diesel Engine Fluids Recommendations" for additional information that relates to lubrication for your engine.

Fuel

Refer to Special Publication, SEBU6251, "Caterpillar Commercial Diesel Engine Fluids Recommendations" for the Caterpillar Specification for distillate fuel and for additional information that relates to fuel for your engine.

Ultra low Sulfur Diesel (ULSD)

Your Caterpillar Diesel Engine must use ultra low sulfur diesel fuel. This fuel complies with the emissions regulations that are prescribed by the Environmental Protection Agency of the United States.

Engines that are manufactured by Caterpillar are certified with the fuel that is prescribed by the United States Environmental Protection Agency. Engines that are manufactured by Caterpillar are certified with the fuel that is prescribed by the European Certification. Caterpillar does not certify diesel engines on any other fuel.

Note: The owner and the operator of the engine has the responsibility of using the fuel that is prescribed by the United States Environmental Protection Agency and other appropriate regulatory agencies.

Fuel tank inlet labels are installed in order to ensure that the correct fuels are used. Illustration 43 is an example of one of the labels designs that will be installed.

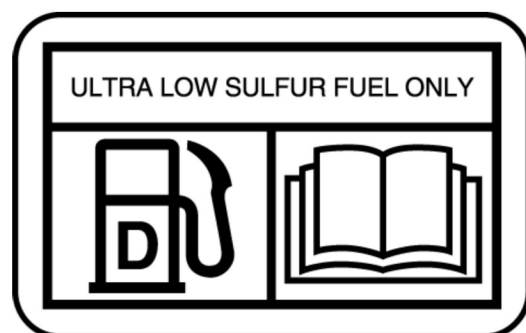

Illustration 43

g02157153

Typical example

Fuel Additives

Many types of fuel additives are available. Caterpillar does not generally recommend the use of fuel additives.

Maintenance Section
Fluid Recommendations

In special circumstances, Caterpillar recognizes the need for fuel additives. Fuel additives must be used with caution. The additive may not be compatible with the fuel. Some additives may precipitate. This action causes deposits in the fuel system. The deposits may cause seizure. Some additives may be corrosive and some additives may be harmful to the elastomers in the fuel system.

Some additives may damage emission control systems. Some additives may cause the amount of sulfur in the fuel to be greater than 15 ppm.

Contact your fuel supplier for those circumstances when fuel additives are required. Your fuel supplier can recommend the best additives for your application and for the proper level of treatment.

Note: For the best results, your fuel supplier should treat the fuel when additives are necessary.

Coolant

The following two coolants are used in Caterpillar diesel engines:

Preferred – Cat ELC (Extended Life Coolant) or a commercial extended life coolant that meets the Caterpillar EC-1 specification

Acceptable – A Cat DEAC (Diesel Engine Antifreeze/Coolant) or a commercial heavy-duty antifreeze that meets “ASTM D6210” specifications

NOTICE

The Caterpillar industrial engine must be operated with a 1:1 mixture of water and glycol. This concentration allows the NOx reduction system to operate correctly at high ambient temperatures.

NOTICE

Do not use a commercial coolant/antifreeze that only meets the ASTM “D3306” or equivalent specification. This type of coolant/antifreeze is made for light duty automotive applications.

Use only the coolant/antifreeze that is recommended.

Caterpillar recommends a 1:1 mixture of water and glycol. This mixture of water and glycol will provide optimum heavy-duty performance as an antifreeze.

Note: Cat DEAC does not require a treatment with an SCA at the initial fill. Commercial heavy-duty antifreeze that meets “ASTM D6210” specifications MAY require a treatment with an SCA at the initial fill. Read the label or the instructions that are provided by the OEM of the product.

In stationary engine applications that do not require anti-boil protection or freeze protection, a mixture of Supplement Coolant Additive (SCA) and water is acceptable. Caterpillar recommends a 6 percent to 8 percent concentration of SCA in those cooling systems. Distilled water or deionized water is preferred. Water which has the recommended properties may be used.

Table 7

Coolant Service Life	
Coolant Type	Service Life ⁽¹⁾
Cat ELC	12000 Service Hours or Six Years ⁽²⁾
Commercial coolant that meets the Caterpillar EC-1 Specification	6000 Service Hours or Six Years ⁽³⁾
Cat DEAC	3000 Service Hours or Three Years
Commercial Heavy-Duty Coolant/Antifreeze that meets “ASTM D6210”	3000 Service Hours or Two Years

⁽¹⁾ Use the interval that occurs first. The cooling system must also be flushed out at this time.

⁽²⁾ Cat ELC Extender must be added at 6000 service hours or one half of the service life of the Cat ELC. Refer to your machine Operation and Maintenance Manual for exceptions.

⁽³⁾ An extender must be added at 3000 service hours or one half of the service life of the coolant.

Note: Refer to Special Publication, SEBU6251, “Caterpillar Commercial Diesel Engine Fluids Recommendations” for additional information that relates to coolant for your engine.

S·O·S Coolant Analysis

Table 8

Recommended Interval		
Type of Coolant	Level 1	Level 2
DEAC	Every 250 Hours ⁽¹⁾	Yearly ⁽¹⁾
ELC	Optional ⁽¹⁾	Yearly

⁽¹⁾ The Level 2 Coolant Analysis should be performed sooner if a problem is identified by a Level 1 Coolant Analysis.

S·O·S Coolant Analysis (Level 1)

A coolant analysis (Level 1) is a test of the properties of the coolant.

The following properties of the coolant are tested:

- Glycol concentration for freeze protection and boil protection
- Ability to protect from erosion and corrosion

- pH
- Conductivity
- Visual analysis
- Odor analysis

The results are reported, and appropriate recommendations are made.

Refer to the Maintenance Interval Schedule in this Operation and Maintenance Manual in order to find the maintenance interval for collecting the coolant samples.

S·O·S Coolant Analysis (Level 2)

A coolant analysis (Level 2) is a comprehensive chemical evaluation of the coolant. This analysis is also a check of the overall condition of the inside of the cooling system.

The S·O·S Coolant Analysis has the following features:

- Full coolant analysis (Level 1)
- Identification of the source of metal corrosion and of contaminants
- Water hardness
- Identification of buildup of the impurities that cause corrosion
- Identification of buildup of the impurities that cause scaling

The results are reported, and appropriate recommendations are made.

Refer to the Maintenance Interval Schedule in this Operation and Maintenance Manual, "Cooling System Coolant Sample (Level 2) - Obtain" for the maintenance interval for collecting the coolant samples.

Testing the engine coolant is important to ensure that the engine is protected from internal cavitation and from corrosion. The analysis also tests the ability of the coolant to protect the engine from boiling and from freezing. The S·O·S Coolant Analysis can be done at your Cat dealer. Caterpillar S·O·S Coolant Analysis is the best way to monitor the condition of your coolant and your cooling system. S·O·S Coolant Analysis is a program that is based on periodic samples.

Refer to Special Publication, SEBU6251, "Caterpillar Commercial Diesel Engine Fluids Recommendations" for additional information.

Maintenance Recommendations

i03648938

System Pressure Release

SMCS Code: 1250; 1300; 1350; 5050

Coolant System

WARNING

Pressurized system: Hot coolant can cause serious burn. To open cap, stop engine, wait until radiator is cool. Then loosen cap slowly to relieve the pressure.

The engine can have the ability to auto start. Ensure that the power supply is isolated before any service or repair is performed.

To relieve the pressure from the coolant system, turn off the engine. Allow the cooling system pressure cap to cool. Remove the cooling system pressure cap slowly in order to relieve pressure.

Fuel System

To relieve the pressure from the fuel system, turn off the engine.

High Pressure Fuel Lines

WARNING

Contact with high pressure fuel may cause fluid penetration and burn hazards. High pressure fuel spray may cause a fire hazard. Failure to follow these inspection, maintenance and service instructions may cause personal injury or death.

The high pressure fuel lines are the fuel lines that are between the high pressure fuel pump and the high pressure fuel manifold and the fuel lines that are between the fuel manifold and cylinder head. These fuel lines are different from fuel lines on other fuel systems.

This is because of the following differences:

- The high pressure fuel lines are constantly charged with high pressure.
- The internal pressures of the high pressure fuel lines are higher than other types of fuel system.

Before any service or repair is performed on the engine fuel lines, perform the following tasks:

1. Stop the engine.

2. Wait for 10 minutes.

Do not loosen the high pressure fuel lines in order to remove air from the fuel system.

Engine Oil

To relieve pressure from the lubricating system, turn off the engine.

i04103075

Welding on Engines with Electronic Controls

SMCS Code: 1000

NOTICE

Because the strength of the frame may decrease, some manufacturers do not recommend welding onto a chassis frame or rail. Consult the OEM of the equipment or your Caterpillar dealer regarding welding on a chassis frame or rail.

Proper welding procedures are necessary in order to avoid damage to the engines ECM, sensors, and associated components. When possible, remove the component from the unit and then weld the component. If removal of the component is not possible, the following procedure must be followed when you weld on a unit equipped with an Electronic Engine. The following procedure is considered to be the safest procedure to weld on a component. This procedure should provide a minimum risk of damage to electronic components.

NOTICE

Do not ground the welder to electrical components such as the ECM or sensors. Improper grounding can cause damage to the drive train bearings, hydraulic components, electrical components, and other components.

Clamp the ground cable from the welder to the component that will be welded. Place the clamp as close as possible to the weld. This will help reduce the possibility of damage.

Note: Perform the welding in areas that are free from explosive hazards.

1. Stop the engine. Turn the switched power to the OFF position.
2. Ensure that the fuel supply to the engine is turned off.
3. Disconnect the negative battery cable from the battery. If a battery disconnect switch is provided, open the switch.

4. Disconnect all electronic components from the wiring harnesses. Include the following components:

- Electronic components for the driven equipment
- ECM
- Sensors
- Electronically controlled valves
- Relays
- Aftertreatment ID module

NOTICE

Do not use electrical components (ECM or ECM sensors) or electronic component grounding points for grounding the welder.

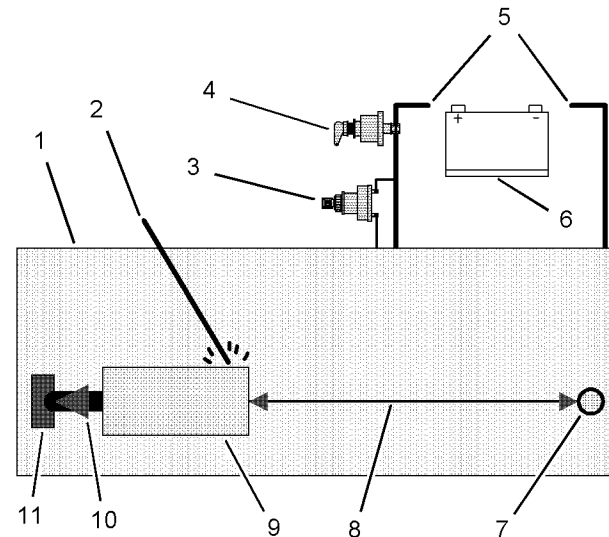

Illustration 44

g01075639

Use the example above. The current flow from the welder to the ground clamp of the welder will not damage any associated components.

- (1) Engine
- (2) Welding electrode
- (3) Keyswitch in the OFF position
- (4) Battery disconnect switch in the open position
- (5) Disconnected battery cables
- (6) Battery
- (7) Electrical/Electronic component
- (8) Minimum distance between the component that is being welded and any electrical/electronic component
- (9) The component that is being welded
- (10) Current path of the welder
- (11) Ground clamp for the welder

5. Connect the welding ground cable directly to the part that will be welded. Place the ground cable as close as possible to the weld in order to reduce the possibility of welding current damage to the following components. Bearings, hydraulic components, electrical components, and ground straps.

Note: If electrical/electronic components are used as a ground for the welder, or electrical/electronic components are located between the welder ground and the weld, current flow from the welder could severely damage the component.

6. Protect the wiring harness from welding debris and spatter.

7. Use standard welding practices to weld the materials.

i04807435

Severe Service Application

SMCS Code: 1000

An engine which operates outside of normal conditions is operating in a severe service application.

An engine that operates in a severe service application may need more frequent maintenance intervals in order to maximize the following conditions:

- Reliability
- Service life

The number of individual applications cause the impossibility of identifying all of the factors which may contribute to severe service operation. Consult your Caterpillar dealer for the unique maintenance that may be necessary for your engine.

An application is a severe service application if any of the following conditions apply:

Severe Environmental Factors

- Frequent operation in dirty air
- Frequent operation at an altitude which is above 1525 m (5000 ft)
- Frequent operation in ambient temperatures which are above 32° C (90° F)
- Frequent operation in ambient temperatures which are below 0° C (32° F)

Severe Operating Conditions

- Frequent operation with inlet air which has a corrosive content
- Operation with inlet air which has a combustible content
- Operation which is outside of the intended application
- Operation with a plugged fuel filter
- Extended operation at low idle (more than 20% of hours)
- Frequent cold starts at temperatures below 0° C (32° F)

- Frequent dry starts (starting after more than 72 hours of shutdown)
- Frequent hot shutdowns (shutting down the engine without the minimum of 2 minutes to 5 minutes of cool down time)
- Operation above the engine rated speed
- Operation below the peak torque speed
- Operating with fuel which does not meet the standards for distillate diesel fuel as stated in Special Publication, SEBU6250, "Caterpillar Machine Fluids Recommendations" "Distillate Diesel Fuel"
- Operating with a blend of distillate fuel which contains more than 20 percent biodiesel

Improper Maintenance Procedures (Maintenance Procedures Which May Contribute to a Severe Service Application)

- Inadequate maintenance of fuel storage tanks from causes such as excessive water, sediment, and microorganism growth.
- Extending maintenance intervals beyond the recommended intervals
- Using fluids which are not recommended in Special Publication, SEBU6250, "Caterpillar Machine Fluids Recommendations"
- Extending maintenance intervals for changing the engine oil and engine coolant without S·O·S validation
- Extending maintenance intervals for changing air filters, oil filters, and fuel filters
- Failure to use a water separator
- Using filters which are not recommended by Special Publication, PEWJ0074, "2008 Cat Filter and Fluid Application Guide"
- Storing the engine for more than 3 months but less than 1 yr (For information about engine storage, refer to Special Publication, SEHS9031, "Storage Procedure for Caterpillar Products")

i05324876

Maintenance Interval Schedule

SMCS Code: 1000; 4450; 7500

When Required

“ Battery - Replace” 76

“ Battery or Battery Cable - Disconnect” 77

“ Engine - Clean”

“ Engine Air Cleaner Element (Single Element) - Inspect/Clean/Replace” 87

“ Fuel System - Prime” 95

Daily

“ Coolant Level - Check” 82

“ Driven Equipment - Check” 86

“ Engine Air Cleaner Service Indicator - Inspect” 87

“ Engine Air Precleaner - Check/Clean” 88

“ Engine Oil Level - Check” 89

“ Fuel System Primary Filter/Water Separator - Drain” 98

“Walk-Around Inspection” 106

Every Week

“ Hoses and Clamps - Inspect/Replace” 100

Every 50 Service Hours or Weekly

“ Fuel Tank Water and Sediment - Drain” 100

Every 250 Service Hours

“ Coolant Sample (Level 1) - Obtain” 83

“ Engine Oil Sample - Obtain” 90

Every 500 Service Hours

“ Fan Clearance - Check” 94

Every 500 Service Hours or 1 Year

“ Battery Electrolyte Level - Check” 77

“ Cooling System Supplemental Coolant Additive (SCA) - Test/Add” 84

“ Engine Air Cleaner Element (Single Element) - Inspect/Clean/Replace” 87

“ Engine Oil and Filter - Change”

“ Fuel System Primary Filter (Water Separator) Element - Replace” 96

“ Fuel System Secondary Filter - Replace” 98

“ Radiator - Clean” 104

Every 1000 Service Hours

“ Water Pump - Inspect” 107

Every 1500 Service Hours

“Engine Crankcase Breather Element - Replace” 88

Every 2000 Service Hours

“ Aftercooler Core - Inspect” 75

“ Coolant Sample (Level 2) - Obtain” 84

“ Engine Mounts - Inspect” 89

“ Starting Motor - Inspect” 105

“ Turbocharger - Inspect” 105

Every 3000 Service Hours

“ Alternator - Inspect” 75

“ Alternator and Fan Belts - Replace” 75

“ Diesel Particulate Filter - Clean” 85

“ Oxygen Sensor - Replace” 104

“ Radiator Pressure Cap - Clean/Replace” 105

Every 3000 Service Hours or 2 Years

“ Coolant (DEAC) - Change” 78

Every 4000 Service Hours

“ Aftercooler Core - Clean/Test” 75

Every 6000 Service Hours or 3 Years

“ Coolant Extender (ELC) - Add” 81

Every 12 000 Service Hours or 6 Years

“ Coolant (ELC) - Change” 80

Overhaul

“ Overhaul Considerations” 101

Commissioning

“ Fan Clearance - Check” 94

i01807350

Aftercooler Core - Clean/Test (Air-To-Air Aftercooler)

SMCS Code: 1064-070; 1064-081

The air-to-air aftercooler is OEM installed in many applications. Please refer to the OEM specifications for information that is related to the aftercooler.

i04380914

Aftercooler Core - Inspect

SMCS Code: 1064-040

Note: Adjust the frequency of cleaning according to the effects of the operating environment.

Inspect the aftercooler for these items: damaged fins, corrosion, dirt, grease, insects, leaves, oil and other debris. Clean the aftercooler, if necessary.

For air-to-air aftercoolers, use the same methods that are used for cleaning radiators.

WARNING

Personal injury can result from air pressure.

Personal injury can result without following proper procedure. When using pressure air, wear a protective face shield and protective clothing.

Maximum air pressure at the nozzle must be less than 205 kPa (30 psi) for cleaning purposes.

Pressurized air is the preferred method for removing loose debris. Direct the air in the opposite direction of the fans air flow. Hold the nozzle approximately 6 mm (.25 inch) away from the fins. Slowly move the air nozzle in a direction that is parallel with the tubes. The pressurized air will remove debris that is between the tubes.

Pressurized water may also be used for cleaning. The maximum water pressure for cleaning purposes must be less than 275 kPa (40 psi). Use pressurized water in order to soften mud. Clean the core from both sides.

Use a degreaser and steam for removal of oil and grease. Clean both sides of the core. Wash the core with detergent and hot water. Thoroughly rinse the core with clean water.

After cleaning, start the engine and accelerate the engine to high idle rpm. This will help in the removal of debris and drying of the core. Stop the engine. Use a light bulb behind the core in order to inspect the core for cleanliness. Repeat the cleaning, if necessary.

Inspect the fins for damage. Bent fins may be opened with a "comb".

Note: If parts of the aftercooler system are repaired or replaced, a leak test is highly recommended. For more information, refer to OEM specification for the aftercooler.

Inspect these items for good condition: welds, mounting brackets, air lines, connections, clamps and seals. Make repairs, if necessary.

i03641972

Alternator - Inspect

SMCS Code: 1405-040

Caterpillar recommends a scheduled inspection of the alternator. Inspect the alternator for loose connections and proper battery charging. Inspect the ammeter (if equipped) during engine operation in order to ensure proper battery performance and/or proper performance of the electrical system. Make repairs, as required.

Check the alternator and the battery charger for proper operation. If the batteries are properly charged, the ammeter reading should be very near zero. All batteries should be kept charged. The batteries should be kept warm because temperature affects the cranking power of the battery. If the battery is too cold, the battery will not crank the engine.

When the engine is not run for long periods of time or if the engine is run for short periods, the batteries may not fully charge. A battery with a low charge will freeze more easily than a battery with a full charge.

i04407613

Alternator and Fan Belts - Replace

SMCS Code: 1357-510

1. Remove the guard that covers the alternator. Refer to the Original Equipment Manufacture (OEM) for the correct procedure.

Maintenance Section
Battery - Replace

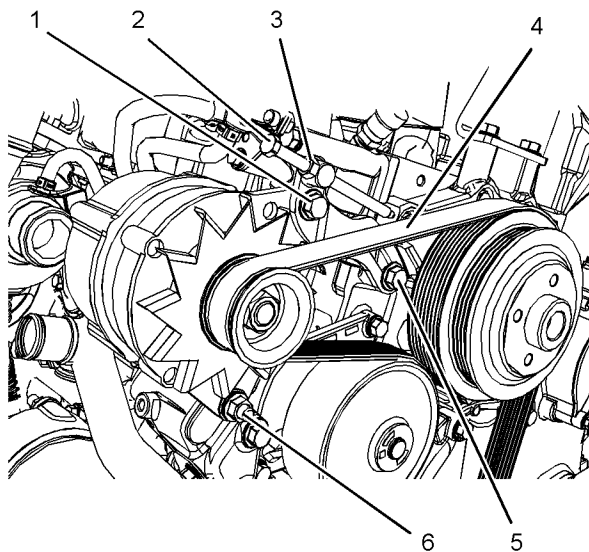

Illustration 45

g02729648

2. Loosen bolt (5) and loosen nut and bolt 6. Also, loosen nut and bolt (1).
3. Loosen nut (3) and turn screw (2) counter clockwise. Turn the screw (2) in order to give clearance to remove the belt (4).
4. Remove belt (4) and visually check all pulleys that the belt operates. Ensure that all pulleys are clean and free from damage. Ensure that the pulleys rotate freely. Replace any component that is damaged.

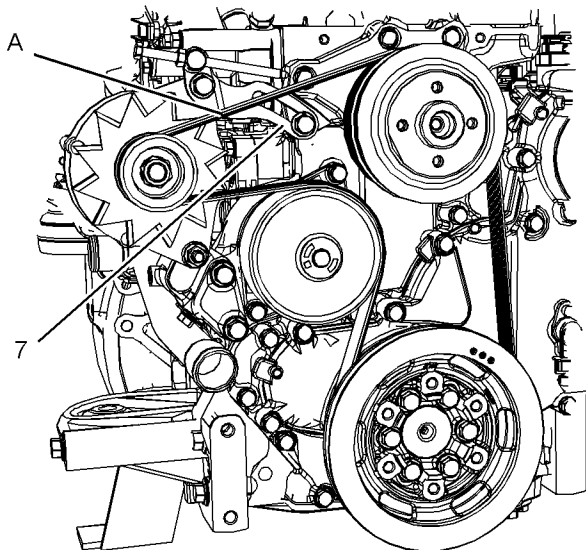

Illustration 46

g02603591

(A) Belt configuration

5. Install the new belt, use belt configuration (A). Visually check that the belt is correctly aligned.
6. Turn the screw (2) clockwise in order to tension the belt. Ensure that the link adjuster (7) is at the maximum extension, refer to illustration 46 .
7. Tighten bolt (5), nut, and bolt (6) and tighten nut and bolt (1). Tighten these nuts and bolts to 50 N·m (37 lb ft).
8. Rotate bolt (2) counter clockwise two complete revolutions and tighten nut (3) to 30 N·m (22 lb ft).
9. Install the guard, refer to OEM for more information.

i03559623

Battery - Replace

SMCS Code: 1401-510

WARNING

Batteries give off combustible gases which can explode. A spark can cause the combustible gases to ignite. This can result in severe personal injury or death.

Ensure proper ventilation for batteries that are in an enclosure. Follow the proper procedures in order to help prevent electrical arcs and/or sparks near batteries. Do not smoke when batteries are serviced.

WARNING

The battery cables or the batteries should not be removed with the battery cover in place. The battery cover should be removed before any servicing is attempted.

Removing the battery cables or the batteries with the cover in place may cause a battery explosion resulting in personal injury.

1. Switch the engine to the OFF position. Remove all electrical loads.
2. Turn off any battery chargers. Disconnect any battery chargers.
3. Ensure that the battery disconnect switch is in the OFF position.
4. Disconnect the NEGATIVE “-” cable from the NEGATIVE “-” battery terminal.
5. Disconnect the POSITIVE “+” cable from the POSITIVE “+” battery terminal.

Note: Always recycle a battery. Never discard a battery. Dispose of used batteries to an appropriate recycling facility.

6. Remove the used battery.
7. Install the new battery.

Note: Before the cables are connected, ensure that the battery disconnect switch is in the OFF position.

8. Connect the POSITIVE "+" cable to the POSITIVE "+" battery terminal.
9. Connect the NEGATIVE "-" cable to the NEGATIVE "-" battery terminal.
10. Turn the battery disconnect switch to the ON position.

i02724529

Battery Electrolyte Level - Check

SMCS Code: 1401-535-FLV

When the engine is not run for long periods of time or when the engine is run for short periods, the batteries may not fully recharge. Ensure a full charge in order to help prevent the battery from freezing. If batteries are properly charged, ammeter reading should be very near zero, when the engine is in operation.

WARNING

All lead-acid batteries contain sulfuric acid which can burn the skin and clothing. Always wear a face shield and protective clothing when working on or near batteries.

1. Remove the filler caps. Maintain the electrolyte level to the "FULL" mark on the battery.

If the addition of water is necessary, use distilled water. If distilled water is not available use clean water that is low in minerals. Do not use artificially softened water.
2. Check the condition of the electrolyte with the 245-5829 Coolant Battery Tester Refractometer.
3. Keep the batteries clean.

Clean the battery case with one of the following cleaning solutions:

 - Use a solution of 0.1 kg (0.2 lb) baking soda and 1 L (1 qt) of clean water.
 - Use a solution of ammonium hydroxide.

Thoroughly rinse the battery case with clean water.

Use a fine grade of sandpaper to clean the terminals and the cable clamps. Clean the items until the surfaces are bright or shiny. DO NOT remove material excessively. Excessive removal of material can cause the clamps to not fit properly. Coat the clamps and the terminals with 5N-5561 Silicone Lubricant, petroleum jelly or MPGM.

i02323088

Battery or Battery Cable - Disconnect

SMCS Code: 1401; 1402-029

WARNING

The battery cables or the batteries should not be removed with the battery cover in place. The battery cover should be removed before any servicing is attempted.

Removing the battery cables or the batteries with the cover in place may cause a battery explosion resulting in personal injury.

1. Turn the start switch to the OFF position. Turn the ignition switch (if equipped) to the OFF position and remove the key and all electrical loads.
2. Disconnect the negative battery terminal. Ensure that the cable cannot contact the terminal. When four 12 volt batteries are involved, two negative connection must be disconnected.
3. Remove the positive connection.
4. Clean all disconnected connection and battery terminals.
5. Use a fine grade of sandpaper to clean the terminals and the cable clamps. Clean the items until the surfaces are bright or shiny. DO NOT remove material excessively. Excessive removal of material can cause the clamps to not fit correctly. Coat the clamps and the terminals with a suitable silicone lubricant or petroleum jelly.
6. Tape the cable connections in order to help prevent accidental starting.
7. Proceed with necessary system repairs.
8. In order to connect the battery, connect the positive connection before the negative connector.

i05324944

Coolant (DEAC) - Change

SMCS Code: 1350-070; 1395-044

Clean the cooling system and flush the cooling system before the recommended maintenance interval if the following conditions exist:

- The engine overheats frequently.
- Foaming is observed.
- The oil has entered the cooling system and the coolant is contaminated.
- The fuel has entered the cooling system and the coolant is contaminated.

NOTICE

Use of commercially available cooling system cleaners may cause damage to cooling system components. Use only cooling system cleaners that are approved for Caterpillar engines.

NOTICE

When any servicing or repair of the engine cooling system is performed the procedure must be performed with the engine on level ground. Level ground will allow you to accurately check the coolant level. This procedure will also help in avoiding the risk of introducing an air lock into the coolant system.

Note: Inspect the water pump and the water temperature regulator after the cooling system has been drained. This inspection is a good opportunity to replace the water pump, the water temperature regulator, and the hoses, if necessary.

Drain

WARNING

Pressurized System: Hot coolant can cause serious burns. To open the cooling system filler cap, stop the engine and wait until the cooling system components are cool. Loosen the cooling system pressure cap slowly in order to relieve the pressure.

1. Stop the engine and allow the engine to cool. Loosen the cooling system filler cap slowly in order to relieve any pressure. Remove the cooling system filler cap.

Note: Refer to Operation and Maintenance Manual, "General Hazard Information" for information on Containing Fluid Spillage.

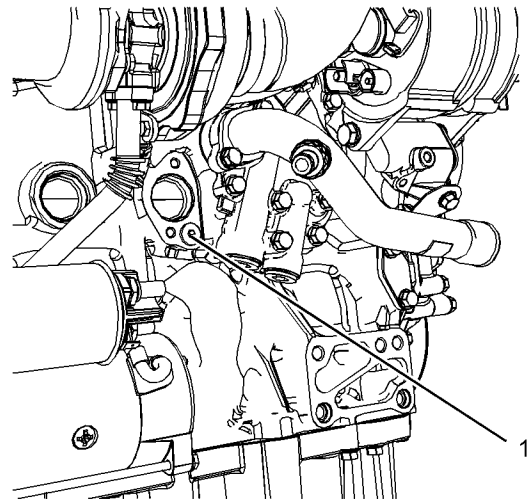

Illustration 47

g02513896

Typical example

2. Remove the drain plug (1) on the engine. Open the drain cock or remove the drain plug on the radiator.
Allow the coolant to drain into a suitable container.
3. Properly dispose of the drained material. Obey local regulations for the disposal of the material.

NOTICE

Dispose of used engine coolant properly or recycle. Various methods have been proposed to reclaim used coolant for reuse in engine cooling systems. The full distillation procedure is the only method acceptable by Caterpillar to reclaim the used coolant.

Flush

1. Flush the cooling system with clean water in order to remove any debris.
2. Clean the drain plugs. Install the drain plugs. Refer to Torque Specifications, SENR3130 for more information on the correct torques.

NOTICE

Do not fill the cooling system faster than 5 L (1.3 US gal) per minute to avoid air locks.

Cooling system air locks may result in engine damage.

3. Fill the cooling system with a mixture of clean water and Caterpillar Fast Acting Cooling System Cleaner. Add 0.5 L (1 pint) of cleaner per 15 L (4 US gal) of the cooling system capacity. Install the cooling system filler cap.
4. Start and run the engine at low idle for a minimum of 30 minutes. The coolant temperature should be at least 82 °C (180 °F).

NOTICE

Improper or incomplete rinsing of the cooling system can result in damage to copper and other metal components.

To avoid damage to the cooling system, make sure to completely flush the cooling system with clear water. Continue to flush the system until all signs of the cleaning agent are gone.

5. Stop the engine and allow the engine to cool. Loosen the cooling system filler cap slowly in order to relieve any pressure. Remove the cooling system filler cap. Remove the cooling system drain plugs. Allow the water to drain. Flush the cooling system with clean water. Clean the drain plugs. Install the drain plugs. Refer to Torque Specifications, SENR3130 for more information on the correct torques.

Cooling Systems with Heavy Deposits or Plugging

Note: For the following procedure to be effective, there must be some active flow through the cooling system components.

1. Flush the cooling system with clean water in order to remove any debris.
2. Clean the drain plugs. Install the drain plugs. Refer to Torque Specifications, SENR3130 for more information on the correct torques.

NOTICE

Do not fill the cooling system faster than 5 L (1.3 US gal) per minute to avoid air locks.

Cooling system air locks may result in engine damage.

3. Fill the cooling system with a mixture of clean water and Caterpillar Fast Acting Cooling System Cleaner. Add 0.5 L (1 pint) of cleaner per 3.8 to 7.6 L (1 to 2 US gal) of the cooling system capacity. Install the cooling system filler cap.

4. Start and run the engine at low idle for a minimum of 90 minutes. The coolant temperature should be at least 82 °C (180 °F).

NOTICE

Improper or incomplete rinsing of the cooling system can result in damage to copper and other metal components.

To avoid damage to the cooling system, make sure to completely flush the cooling system with clear water. Continue to flush the system until all signs of the cleaning agent are gone.

5. Stop the engine and allow the engine to cool. Loosen the cooling system filler cap slowly in order to relieve any pressure. Remove the cooling system filler cap. Remove the cooling system drain plugs. Allow the water to drain. Flush the cooling system with clean water. Clean the drain plugs. Install the drain plugs. Refer to Torque Specifications, SENR3130 for more information on the correct torques.

Fill

NOTICE

Do not fill the cooling system faster than 5 L (1.3 US gal) per minute to avoid air locks.

Cooling system air locks may result in engine damage.

1. Fill the cooling system with the coolant/antifreeze. Refer to this Operation and Maintenance Manual, "Refill Capacities and Recommendations" topic (Maintenance Section) for more information on cooling system specifications. Do not install the cooling system filler cap.
2. Start and run the engine at low idle. Increase the engine rpm to high idle. Operate the engine in order to open the engine thermostat. This operation will allow any air in the system to be purged. Decrease the engine speed to low idle. Stop the engine.
3. Maintain the coolant level at the maximum mark that is correct for your application.

4. Clean the cooling system filler cap. Inspect the gasket that is on the cooling system filler cap. If the gasket that is on the cooling system filler cap is damaged, discard the old cooling system filler cap and install a new cooling system filler cap. If the gasket that is on the cooling system filler cap is not damaged, perform a pressure test. A 9S-8140 Pressurizing Pump is used to perform the pressure test. The correct pressure for the cooling system filler cap is stamped on the face of the cooling system filler cap. If the cooling system filler cap does not retain the correct pressure, install a new cooling system filler cap.
5. Start the engine. Inspect the cooling system for leaks and for the correct operating temperature.

i05324974

Coolant (ELC) - Change

SMCS Code: 1350-070; 1395-044

Clean the cooling system and flush the cooling system before the recommended maintenance interval if the following conditions exist:

- The engine overheats frequently.
- Foaming is observed.
- The oil has entered the cooling system and the coolant is contaminated.
- The fuel has entered the cooling system and the coolant is contaminated.

Note: When the cooling system is cleaned, only clean water is needed when the ELC is drained and replaced.

Note: Inspect the water pump and the water temperature regulator after the cooling system has been drained. Replace the water pump, the water temperature regulator, and the hoses, if necessary.

NOTICE

Service or repair of the engine cooling system must be performed on level ground. The engine must be level in order to check the coolant level. The engine must be level in order to avoid the risk of introducing an air lock into the coolant system.

Drain

WARNING

Pressurized System: Hot coolant can cause serious burns. To open the cooling system filler cap, stop the engine and wait until the cooling system components are cool. Loosen the cooling system pressure cap slowly in order to relieve the pressure.

1. Stop the engine and allow the engine to cool. Loosen the cooling system filler cap slowly in order to relieve any pressure. Remove the cooling system filler cap.

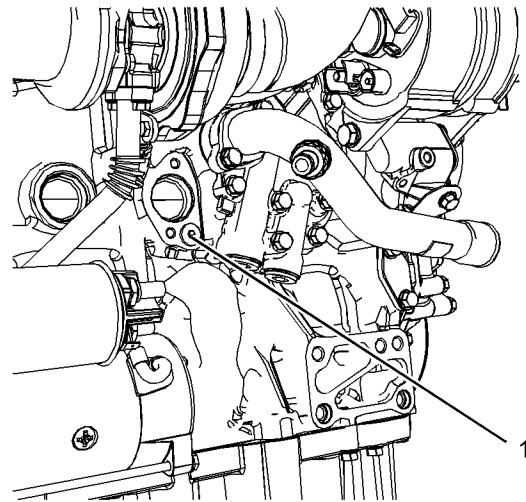

Illustration 48

g02513896

Typical example

2. Remove the drain plug (1) on the engine. Open the drain cock or remove the drain plug on the radiator.

Allow the coolant to drain.

NOTICE

Dispose of used engine coolant properly or recycle. Various methods have been proposed to reclaim used coolant for reuse in engine cooling systems. The full distillation procedure is the only method acceptable by Caterpillar to reclaim the used coolant.

For information regarding the disposal and the recycling of used coolant, consult your Caterpillar dealer.

Flush

1. Flush the cooling system with clean water in order to remove any debris.
2. Clean the drain plugs. Install the drain plugs. Refer to Torque Specifications, SENR3130 for more information on the correct torques.

NOTICE

Do not fill the cooling system faster than 5 L (1.3 US gal) per minute to avoid air locks.

Cooling system air locks may result in engine damage.

3. Fill the cooling system with clean water. Install the cooling system filler cap.
4. Start and run the engine at low idle until the temperature reaches 49 to 66 °C (120 to 150 °F).
5. Stop the engine and allow the engine to cool. Loosen the cooling system filler cap slowly in order to relieve any pressure. Remove the cooling system filler cap. Remove the cooling system drain plugs. Allow the water to drain. Flush the cooling system with clean water. Clean the drain plugs. Install the drain plugs. Refer to Torque Specifications, SENR3130 for more information on the correct torques.

Fill

NOTICE

Do not fill the cooling system faster than 5 L (1.3 US gal) per minute to avoid air locks.

Cooling system air locks may result in engine damage.

1. Fill the cooling system with Extended Life Coolant (ELC). Refer to this Operation and Maintenance Manual, "Refill Capacities and Recommendations" topic (Maintenance Section) for more information on cooling system specifications. Do not install the cooling system filler cap.
2. Start and run the engine at low idle. Increase the engine rpm to high idle. Operate the engine in order to open the engine thermostat. An open thermostat will allow any air in the system to be purged. Decrease the engine speed to low idle. Stop the engine.

3. Maintain the coolant level at the maximum mark that is correct for your application.
4. Clean the cooling system filler cap. Inspect the gasket that is on the cooling system filler cap. If the gasket that is on the cooling system filler cap is damaged, discard the old cooling system filler cap and install a new cooling system filler cap. If the gasket that is on the cooling system filler cap is not damaged, use a 9S-8140 Pressurizing Pump in order to pressure test the cooling system filler cap. The correct pressure for the cooling system filler cap is stamped on the face of the cooling system filler cap. If the cooling system filler cap does not retain the correct pressure, install a new cooling system filler cap.
5. Start the engine. Inspect the cooling system for leaks and for proper operating temperature.

i05324989

Coolant Extender (ELC) - Add

SMCS Code: 1352-544-NL

Cat ELC (Extended Life Coolant) does not require the frequent additions of any supplemental cooling additives which are associated with the present conventional coolants. The Cat ELC Extender only needs adding once.

NOTICE

Use only Cat Extended Life Coolant (ELC) Extender with Cat ELC.

Do NOT use conventional supplemental coolant additive (SCA) with Cat ELC. Mixing Cat ELC with conventional coolants and/or conventional SCA reduces the Cat ELC service life.

Check the cooling system only when the engine is stopped and cool.

⚠ WARNING

Personal injury can result from hot coolant, steam and alkali.

At operating temperature, engine coolant is hot and under pressure. The radiator and all lines to heaters or the engine contain hot coolant or steam. Any contact can cause severe burns.

Remove cooling system pressure cap slowly to relieve pressure only when engine is stopped and cooling system pressure cap is cool enough to touch with your bare hand.

Do not attempt to tighten hose connections when the coolant is hot, the hose can come off causing burns.

Cooling System Coolant Additive contains alkali. Avoid contact with skin and eyes.

NOTICE

Care must be taken to ensure that fluids are contained during performance of inspection, maintenance, testing, adjusting, and repair of the product. Be prepared to collect the fluid with suitable containers before opening any compartment or disassembling any component containing fluids.

Refer to Cat Hand Tools and Shop Supplies for suitable contains use on Cat products.

Dispose of all fluids according to local regulations and mandates.

NOTICE

When any servicing or repair of the engine cooling system is performed, the procedure must be performed with the engine on level ground. This procedure will allow you to check accurately the coolant level. This procedure will also help in avoiding the risk of introducing an air lock into the coolant system.

1. Loosen the cooling system filler cap slowly in order to relieve pressure. Remove the cooling system filler cap.
2. If necessary, drain enough coolant from the cooling system in order to add the Cat ELC Extender.
3. Add Cat ELC Extender according to the requirements for your engines cooling system capacity. Refer to the Operation and Maintenance Manual, "Refill Capacities and Recommendations" article for more information.

4. Clean the cooling system filler cap. Inspect the gaskets on the cooling system filler cap. Replace the cooling system filler cap if the gaskets are damaged. Install the cooling system filler cap.

i05325007

Coolant Level - Check

SMCS Code: 1395-082

Check the coolant level when the engine is stopped and cool.

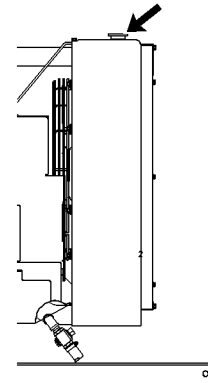

Illustration 49

g00285520

Cooling system filler cap

⚠ WARNING

Pressurized System: Hot coolant can cause serious burns. To open the cooling system filler cap, stop the engine and wait until the cooling system components are cool. Loosen the cooling system pressure cap slowly in order to relieve the pressure.

1. Remove the cooling system filler cap slowly in order to relieve pressure.
2. Maintain the coolant level within 13 mm (0.5 inch) of the bottom of the filler pipe. If the engine is equipped with a sight glass, maintain the coolant level to the proper level in the sight glass.

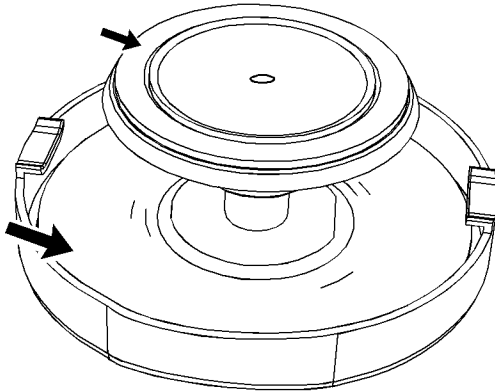

Illustration 50

g02590196

Typical filler cap gaskets

3. Clean the cooling system filler cap and check the condition of the filler cap gaskets. Replace the cooling system filler cap if the filler cap gaskets are damaged. Reinstall the cooling system filler cap.
4. Inspect the cooling system for leaks.

i05164397

Coolant Sample (Level 1) - Obtain

SMCS Code: 1350-008; 1395-008; 1395-554; 7542

Note: Obtaining a Coolant Sample (Level 1) is optional if the cooling system is filled with Cat ELC (Extended Life Coolant). Cooling systems filled with Cat ELC should have a Coolant Sample (Level 2) that is obtained at the recommended interval as stated in the maintenance interval schedule.

Note: Obtain a Coolant Sample (Level 1) if the cooling system is filled with any other coolant instead of Cat ELC including the following coolants:

- Commercial long life coolants that meet the Caterpillar Engine Coolant Specification -1 (Caterpillar EC-1)
- Cat DEAC (Diesel Engine Antifreeze/Coolant)
- Commercial heavy-duty coolant/antifreeze

Table 9

Type of Coolant	Recommended Interval	
	Level 1	Level 2
Cat DEAC	Every 250 service hours	2000 Hours or Every year ⁽¹⁾
Conventional heavy duty-coolant		
Cat ELC or conventional EC-1 coolant	Optional	2000 Hours or Every year ⁽¹⁾

⁽¹⁾ The Level 2 Coolant Analysis should be performed sooner if a problem is suspected or identified.

NOTICE

Always use a designated pump for oil sampling, and use a separate designated pump for coolant sampling. Using the same pump for both types of samples may contaminate the samples that are being drawn. This contaminate may cause a false analysis and an incorrect interpretation that could lead to concerns by both dealers and customers.

Note: Level 1 results may indicate a need for Level 2 Analysis.

Obtain the sample of the coolant as close as possible to the recommended sampling interval. In order to receive the full effect of S·O·S analysis, establish a consistent trend of data. In order to establish a pertinent history of data, perform consistent samplings that are evenly spaced. Supplies for collecting samples can be obtained from your Cat dealer.

Use the following guidelines for proper sampling of the coolant:

- Complete the information on the label for the sampling bottle before you begin to take the samples.
- Keep the unused sampling bottles stored in plastic bags.
- Obtain coolant samples directly from the coolant sample port. You should not obtain the samples from any other location.
- Keep the lids on empty sampling bottles until you are ready to collect the sample.
- Place the sample in the mailing tube immediately after obtaining the sample in order to avoid contamination.
- Never collect samples from expansion bottles.
- Never collect samples from the drain for a system.

Submit the sample for Level 1 analysis.

Maintenance Section
Coolant Sample (Level 2) - Obtain

For additional information about coolant analysis, see this Operation and Maintenance Manual, "Fluid Recommendations" or consult your Cat dealer.

i03644817

i04913805

Coolant Sample (Level 2) - Obtain

SMCS Code: 1350-008; 1395-008; 1395-554; 7542

NOTICE

Always use a designated pump for oil sampling, and use a separate designated pump for coolant sampling. Using the same pump for both types of samples may contaminate the samples that are being drawn. This contaminate may cause a false analysis and an incorrect interpretation that could lead to concerns by both dealers and customers.

NOTICE

Care must be taken to ensure that fluids are contained during performance of inspection, maintenance, testing, adjusting and repair of the product. Be prepared to collect the fluid with suitable containers before opening any compartment or disassembling any component containing fluids.

Refer to Special Publication, NENG2500, "Caterpillar Dealer Service Tool Catalog" or refer to Special Publication, PECJ0003, "Caterpillar Shop Supplies and Tools Catalog" for tools and supplies suitable to collect and contain fluids on Caterpillar products.

Dispose of all fluids according to local regulations and mandates.

Refer to Operation and Maintenance Manual, "Cooling System Coolant Sample (Level 1) - Obtain" for the guidelines for proper sampling of the coolant.

Submit the sample for Level 2 analysis.

For additional information about coolant analysis, see Special Publication, SEBU6251, "Caterpillar Commercial Diesel Engines Fluids Recommendations" or consult your Caterpillar dealer.

Cooling System Supplemental Coolant Additive (SCA) - Test/Add

SMCS Code: 1352-045; 1395-081

WARNING

Cooling system coolant additive contains alkali. To help prevent personal injury, avoid contact with the skin and the eyes. Do not drink cooling system coolant additive.

Note: Test the concentration of the Supplemental Coolant Additive (SCA) or test the SCA concentration as part of an S·O·S Coolant Analysis.

Test for SCA Concentration

Coolant and SCA

NOTICE

Do not exceed the recommended six percent supplemental coolant additive concentration.

Use the 8T-5296 Coolant Conditioner Test Kit or use the 4C-9301 Coolant Conditioner Test Kit in order to check the concentration of the SCA. Refer to this Operation and Maintenance Manual, "Refill Capacities and Recommendations" for more information.

Water and SCA

NOTICE

Do not exceed the recommended eight percent supplemental coolant additive concentration.

Test the concentration of the SCA with the 8T-5296 Coolant Conditioner Test Kit. Refer to the Special Publication, SEBU6251, "Caterpillar Commercial Diesel Engine Fluids Recommendations" for more information.

S·O·S Coolant Analysis

S·O·S coolant samples can be analyzed at your Caterpillar dealer. S·O·S Coolant Analysis is a program that is based on periodic samples.

Level 1

Level 1 is a basic analysis of the coolant. The following items are tested:

- Glycol Concentration
- Concentration of SCA

- pH
- Conductivity

The results are reported, and recommendations are made according to the results. Consult your Caterpillar dealer for information on the benefits of managing your equipment with an S·O·S Coolant Analysis.

Level 2

This level coolant analysis is recommended when the engine is overhauled. Refer to this Operations and Maintenance Manual, "Overhaul Considerations" for further information.

Add the SCA, If Necessary

NOTICE

Do not exceed the recommended amount of supplemental coolant additive concentration. Excessive supplemental coolant additive concentration can form deposits on the higher temperature surfaces of the cooling system, reducing the engine's heat transfer characteristics. Reduced heat transfer could cause cracking of the cylinder head and other high temperature components. Excessive supplemental coolant additive concentration could also result in radiator tube blockage, overheating, and/or accelerated water pump seal wear. Never use both liquid supplemental coolant additive and the spin-on element (if equipped) at the same time. The use of those additives together could result in supplemental coolant additive concentration exceeding the recommended maximum.

WARNING

Pressurized System: Hot coolant can cause serious burns. To open the cooling system filler cap, stop the engine and wait until the cooling system components are cool. Loosen the cooling system pressure cap slowly in order to relieve the pressure.

NOTICE

When any servicing or repair of the engine cooling system is performed the procedure must be performed with the engine on level ground. This will allow you to accurately check the coolant level. This will also help in avoiding the risk of introducing an air lock into the coolant system.

1. Slowly loosen the cooling system filler cap in order to relieve the pressure. Remove the cooling system filler cap.

Note: Always discard drained fluids according to local regulations.

2. If necessary, drain some coolant from the cooling system into a suitable container in order to allow space for the extra SCA.
3. Add the proper amount of SCA. Refer to the Special Publication, SEBU6251, "Caterpillar Commercial Diesel Engines Fluids Recommendations" for more information on SCA requirements.
4. Clean the cooling system filler cap. Inspect the gaskets of the cooling system filler cap. If the gaskets are damaged, replace the old cooling system filler cap with a new cooling system filler cap. Install the cooling system filler cap.

i04403234

Diesel Particulate Filter - Clean

SMCS Code: 108F-070

WARNING

Wear goggles, gloves, protective clothing, and a National Institute for Occupational Safety and Health (NIOSH) approved P95 or N95 half-face respirator when handling a used Diesel Particulate Filter or Catalytic Converter Muffler. Failure to do so could result in personal injury.

WARNING

The muffler, catalytic converter/muffler, and diesel particulate filter will become extremely hot during engine operation. A hot muffler, catalytic converter/muffler and diesel particulate filter can cause serious burns. Allow adequate cooling time before working on or near the muffler, catalytic converter/muffler and diesel particulate filter.

i06709044

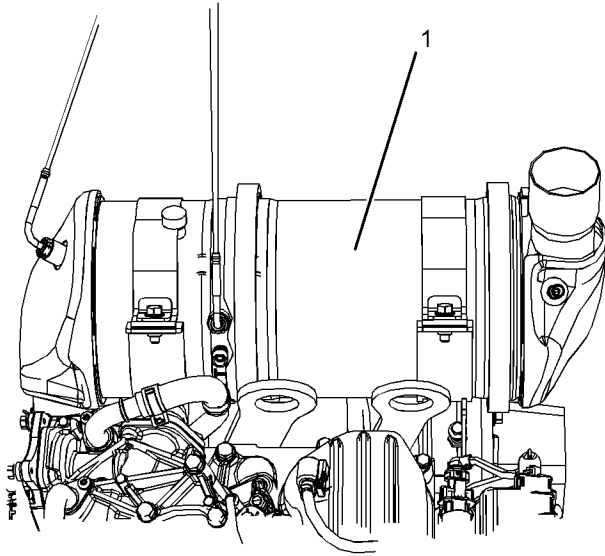

Illustration 51

g02524596

Typical example

Note: Only the wall flow type of aftertreatment requires a service period, in order to remove the ash. The wall flow aftertreatment uses active regeneration in order to remove soot.

For information on removal of the (1) diesel particulate filter, refer to Disassembly and Assembly, "DPF - Remove".

Only ultra low sulfur diesel fuel can be used in an application that has an aftertreatment system installed.

Caterpillar recommend the use of Cat DEO-ULS engine oil.

i00174798

Driven Equipment - Check

SMCS Code: 3279-535

Refer to the OEM specifications for more information on the following maintenance recommendations for the driven equipment:

- Inspection
- Adjustment
- Lubrication
- Other maintenance recommendations

Perform any maintenance for the driven equipment which is recommended by the OEM.

Engine - Clean

SMCS Code: 1000-070

WARNING

Personal injury or death can result from high voltage.

Moisture can create paths of electrical conductivity.

Make sure that the electrical system is OFF. Lock out the starting controls and tag the controls "DO NOT OPERATE" .

NOTICE

Accumulated grease and oil on an engine is a fire hazard. Keep the engine clean. Remove debris and fluid spills whenever a significant quantity accumulates on the engine.

Periodic cleaning of the engine is recommended. Steam cleaning the engine will remove accumulated oil and grease. A clean engine provides the following benefits:

- Easy detection of fluid leaks
- Maximum heat transfer characteristics
- Ease of maintenance

Note: Caution must be used to prevent electrical components from being damaged by excessive water when the engine is cleaned. Pressure washers and steam cleaners should not be directed at any electrical connectors or the junction of cables into the rear of the connectors. Avoid electrical components such as the alternator, the starter, and the ECM. Protect the fuel injection pump from fluids to wash the engine.

Ensure that care is taken that the safety labels, emission label, and any information labels are not removed during engine cleaning.

Ensure that care is taken that the safety labels, emission label, and all other information labels are not removed during engine cleaning.

Aftertreatment

During the engine cleaning process, ensure that water or cleaning fluids cannot enter the aftertreatment system. If cleaning fluids enters the aftertreatment system, damage could occur.

i04150591

Engine Air Cleaner Element (Single Element) - Inspect/Clean/Replace

SMCS Code: 1051; 1054-070; 1054-040; 1054-510

Refer to Operation and Maintenance Manual, "Engine Air Cleaner Service Indicator-Inspect".

NOTICE

Never run the engine without an air cleaner element installed. Never run the engine with a damaged air cleaner element. Do not use air cleaner elements with damaged pleats, gaskets or seals. Dirt entering the engine causes premature wear and damage to engine components. Air cleaner elements help to prevent airborne debris from entering the air inlet.

NOTICE

Never service the air cleaner element with the engine running since this will allow dirt to enter the engine.

A wide variety of air cleaners may be installed for use with this engine. Consult the OEM information for the correct procedure to replace the air cleaner.

i02335405

Engine Air Cleaner Service Indicator - Inspect

SMCS Code: 7452-040

Some engines may be equipped with a different service indicator.

Some engines are equipped with a differential gauge for inlet air pressure. The differential gauge for inlet air pressure displays the difference in the pressure that is measured before the air cleaner element and the pressure that is measured after the air cleaner element. As the air cleaner element becomes dirty, the pressure differential rises. If your engine is equipped with a different type of service indicator, follow the OEM recommendations in order to service the air cleaner service indicator.

The service indicator may be mounted on the air cleaner element or in a remote location.

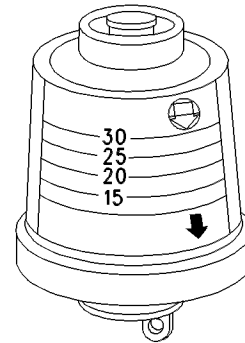

Illustration 52

g00103777

Typical service indicator

Observe the service indicator. The air cleaner element should be cleaned or the air cleaner element should be replaced when one of the following conditions occur:

- The yellow diaphragm enters the red zone.
- The red piston locks in the visible position.

Test the Service Indicator

Service indicators are important instruments.

- Check for ease of resetting. The service indicator should reset in less than three pushes.
- Check the movement of the yellow core when the engine is accelerated to the engine rated speed. The yellow core should latch at the greatest vacuum that is attained.

If the service indicator does not reset easily, or if the yellow core does not latch at the greatest vacuum, the service indicator should be replaced. If the new service indicator will not reset, the hole for the service indicator may be restricted.

The service indicator may need to be replaced frequently in environments that are severely dusty.

i02927289

Engine Air Precleaner - Check/Clean

SMCS Code: 1055-070; 1055-535

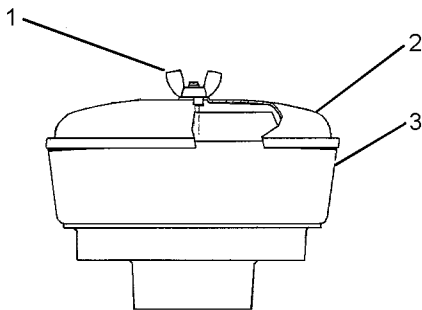

Illustration 53

g01453058

Typical engine air precleaner

- (1) Wing nut
 (2) Cover
 (3) Body

Remove wing nut (1) and cover (2). Check for an accumulation of dirt and debris in body (3). Clean the body, if necessary.

After cleaning the precleaner, install cover (2) and wing nut (1).

Note: When the engine is operated in dusty applications, more frequent cleaning is required.

i04725716

Engine Crankcase Breather Element - Replace

SMCS Code: 1317-510-FQ

WARNING

Hot oil and hot components can cause personal injury. Do not allow hot oil or hot components to contact the skin.

Engine Breather

NOTICE

Ensure that the engine is stopped before any servicing or repair is performed.

The crankcase breather is a very important component in order to keep your engine emissions compliant.

- The filter element within the crankcase breather must be serviced at the prescribed service interval.
- The correct filter element must be installed before the engine is operated.
- The installation of the filter element is very important.
- The quality of the filter element that is installed is very important.
- The filter element protects the engine from excessive quantities of oil from entering the induction system. The filter element also protects the engine aftertreatment system.

Note: Excessive quantities of oil that enter the induction system of the engine can rapidly increase the engine speed without control.

Remove the Breather Element

1. Remove the guard that covers the engine breather, refer to the Original Equipment Manufacture (OEM) for more information.

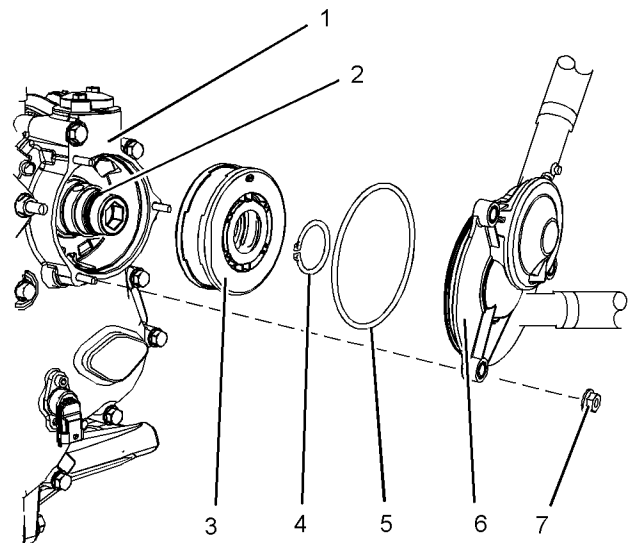

Illustration 54

g02827199

Typical example

2. If necessary, remove breather pipes on cover (6). Remove nuts (7) and remove cover (6) from housing (1).
3. Remove circlip (4) and remove the breather element (3) and discard.
4. Remove the O ring seal (5) from the cover.

Install the Breather Element

Ensure that all the components are clean and free from damage.

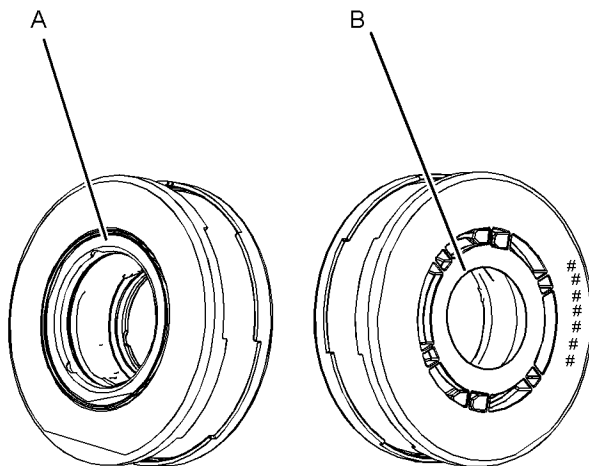

Illustration 55

g02827300

Typical example

- (A) Diameter
(B) Diameter

1. Install a new O ring seal (5) onto the cover (6).

Note: The breather element must have the correct orientation before installation. Diameter (A) is visibly larger than diameter (B).

2. Install diameter (A) of the breather element (3) onto the shaft (2). When correctly installed the part number of the breather element will be visible.
3. Install circlip (4) and cover (6). Install nuts (7) and tighten to 25 N·m (18 lb ft). If necessary, install breather pipes to cover.

4. Install the guard, refer to OEM.

i02456872

Engine Mounts - Inspect

SMCS Code: 1152; 1152-040

Inspect the engine mounts for deterioration and for proper bolt torque. Engine vibration can be caused by the following conditions:

- Improper mounting of the engine
- Deterioration of the engine mounts

Any engine mount that shows deterioration should be replaced. Refer to Special Publication, SENR3130, "Torque Specifications" for the recommended torques. Refer to the OEM recommendations for more information.

i04728471

Engine Oil Level - Check

SMCS Code: 1348-535-FLV

WARNING

Hot oil and hot components can cause personal injury. Do not allow hot oil or hot components to contact the skin.



Illustration 56

g02829378

Typical example

NOTICE

Perform this maintenance with the engine stopped.

Note: Ensure that the engine is either level or that the engine is in the normal operating position in order to obtain a true level indication.

Note: After the engine has been switched OFF, wait for 10 minutes in order to allow the engine oil to drain to the oil pan before checking the oil level.

1. Maintain the oil level between the MIN mark and the mark MAX on the engine oil dipstick. Do not fill the crankcase above the MAX mark.

NOTICE

Operating your engine when the oil level is above the MAX mark could cause your crankshaft to dip into the oil. The air bubbles created from the crankshaft dipping into the oil reduces the oils lubricating characteristics and could result in the loss of power.

2. Remove the oil filler cap and add oil, if necessary. Clean the oil filler cap. Install the oil filler cap. If an increase in the oil level is noticed, refer to Troubleshooting, "Oil Contains Fuel".

i04237495

Engine Oil Sample - Obtain

SMCS Code: 1348-554-SM

In addition to a good preventive maintenance program, Caterpillar recommends using S·O·S oil analysis at regularly scheduled intervals. S·O·S oil analysis provides infrared analysis, which is required for determining nitration and oxidation levels.

Obtain the Sample and the Analysis

 **WARNING**

Hot oil and hot components can cause personal injury. Do not allow hot oil or hot components to contact the skin.

Before you take the oil sample, complete the Label, PEEP5031 for identification of the sample. In order to help obtain the most accurate analysis, provide the following information:

- Engine model
- Service hours on the engine
- The number of hours that have accumulated since the last oil change
- The amount of oil that has been added since the last oil change

To ensure that the sample is representative of the oil in the crankcase, obtain a warm, mixed oil sample.

To avoid contamination of the oil samples, the tools and the supplies that are used for obtaining oil samples must be clean.

Caterpillar recommends using the sampling valve in order to obtain oil samples. The quality and the consistency of the samples are better when the sampling valve is used. The location of the sampling valve allows oil that is flowing under pressure to be obtained during normal engine operation.

The 169-8373 Fluid Sampling Bottle is recommended for use with the sampling valve. The fluid sampling bottle includes the parts that are needed for obtaining oil samples. Instructions are also provided.

NOTICE

Always use a designated pump for oil sampling, and use a separate designated pump for coolant sampling. Using the same pump for both types of samples may contaminate the samples that are being drawn. This contaminate may cause a false analysis and an incorrect interpretation that could lead to concerns by both dealers and customers.

If the engine is not equipped with a sampling valve, use the 1U-5718 Vacuum Pump. The pump is designed to accept sampling bottles. Disposable tubing must be attached to the pump for insertion into the sump.

For instructions, see Special Publication, PEGJ0047, "How To Take A Good S·O·S Oil Sample". Consult your Cat dealer for complete information and assistance in establishing an S·O·S program for your engine.

i06708989

Engine Oil and Filter - Change

SMCS Code: 1318-510

 **WARNING**

Hot oil and hot components can cause personal injury. Do not allow hot oil or hot components to contact the skin.

NOTICE

Care must be taken to ensure that fluids are contained during performance of inspection, maintenance, testing, adjusting and repair of the product. Be prepared to collect the fluid with suitable containers before opening any compartment or disassembling any component containing fluids.

Dispose of all fluids according to local regulations and mandates.

NOTICE

Keep all parts clean from contaminants.

Contaminants may cause rapid wear and shortened component life.

The engine oil service reset procedure must be completed after the engine oil, and filter have been changed. Refer to "Engine Oil Service Reset" for more information.

Do not drain the engine lubricating oil when the engine is cold. As the engine lubricating oil cools, suspended waste particles settle on the bottom of the oil pan. The waste particles are not removed with draining cold oil. Drain the oil pan with the engine stopped. Drain the oil pan with the oil warm. This draining method allows the waste particles that are suspended in the oil to be drained properly.

Failure to follow this recommended procedure will cause the waste particles to be recirculated through the engine lubrication system with the new oil.

Drain the Engine Lubricating Oil

Note: Ensure that the vessel that will be used is large enough to collect the waste oil.

After the engine has been run at the normal operating temperature, stop the engine. Use one of the following methods to drain the engine oil pan:

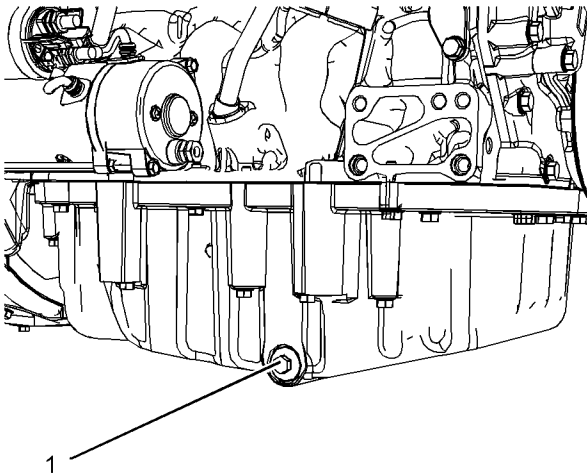

Illustration 57

g02519103

- If the engine is equipped with a drain valve, turn the drain valve knob counterclockwise to drain the oil. After the oil has drained, turn the drain valve knob clockwise to close the drain valve.

- If the engine is not equipped with a drain valve, remove oil drain plug (1) to allow the oil to drain. If the engine is equipped with a shallow oil pan, remove the bottom oil drain plugs from both ends of the oil pan.

After the oil has drained, the oil drain plugs should be cleaned and installed. If necessary, replace the O ring seal. Tighten the drain plug securely.

Replace the Oil Filter**NOTICE**

Caterpillar oil filters are manufactured to Caterpillar specifications. Use of an oil filter that is not recommended by Caterpillar could result in severe damage to the engine bearings, crankshaft. As a result of the larger waste particles from unfiltered oil entering the engine lubricating system. Only use oil filters recommended by Caterpillar.

1. Remove the oil filter.

Note: The following actions can be carried out as part of the preventive maintenance program.

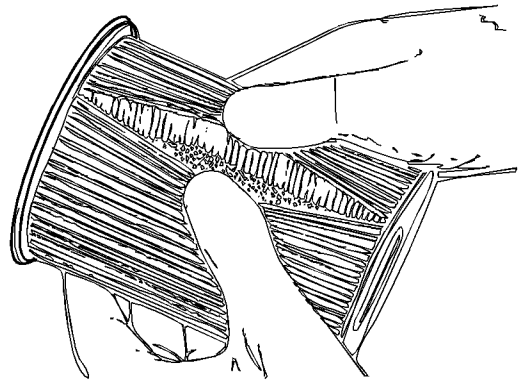

Illustration 58

g01999595

Element with debris

2. Cut the oil filter open with a 175-7546 Oil Filter Cutter. Break apart the pleats and inspect the oil filter for metal debris. An excessive amount of metal debris in the oil filter may indicate early wear or a pending failure.

Use a magnet to differentiate between the ferrous metals and the nonferrous metals that are found in the oil filter element. Ferrous metals may indicate wear on the steel and cast iron parts of the engine.

Maintenance Section
Engine Oil and Filter - Change

Nonferrous metals may indicate wear on the aluminum parts, brass parts, or bronze parts of the engine. Parts that may be affected include the following items: main bearings, rod bearings, turbocharger bearings, and cylinder heads.

Due to normal wear and friction, small amounts of debris is not uncommon to be found in the oil filter. Consult your Cat dealer to arrange for a further analysis if an excessive amount of debris is found in the oil filter.

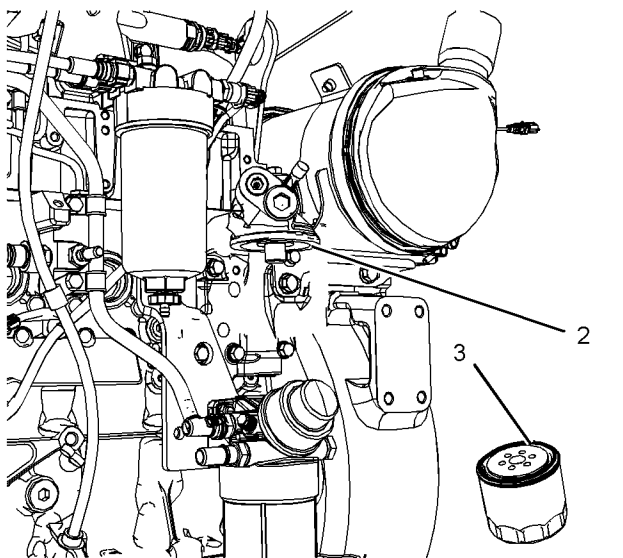

Illustration 59

g02516777

Typical example

3. Clean the sealing surface of the oil filter base (2).
4. Apply clean engine oil to the O ring seal (3) for the new oil filter.

NOTICE

Do not fill the oil filters with oil before installing them. This oil would not be filtered and could be contaminated. Contaminated oil can cause accelerated wear to engine components or engine damage.

5. Install the engine oil filter, spin on the oil filter until the O ring seal contacts the oil filter base. Then, rotate the oil filter $\frac{3}{4}$ of a full turn, by hand only.

Vertically Up Oil Filter

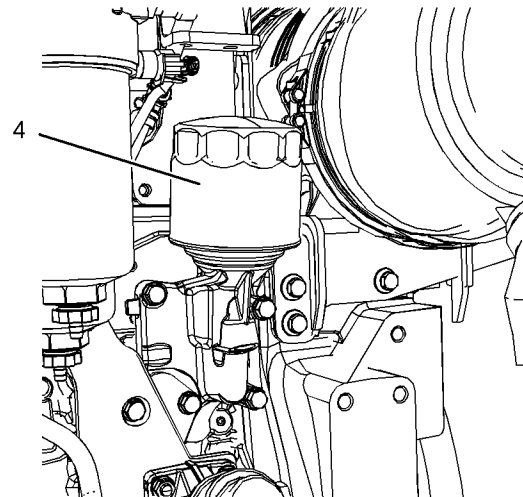

Illustration 60

g02596778

(4) Vertically up oil filter

Some oil filters may be installed vertically up. Use the same procedure to replace the oil filter. Ensure that all the oil has drained from the filter before removal.

Fill the Oil Pan

1. Remove the oil filler cap. Refer to this Operation and Maintenance Manual, "Fluid Recommendations" for more information on suitable oils. Fill the oil pan with the correct amount of new engine lubricating oil. Refer to this Operation and Maintenance Manual, "Refill Capacities" for more information on refill capacities.

NOTICE

If equipped with an auxiliary oil filter system or a remote filter system, follow the OEM or the filter manufacturer's recommendations. Under filling or over filling the crankcase with oil can cause engine damage.

2. Start the engine and run the engine at "LOW IDLE" for 2 minutes. Perform this procedure to ensure that the lubrication system has oil and that the oil filters are filled. Inspect the oil filter for oil leaks.
3. Stop the engine and allow the oil to drain back to the oil pan for a minimum of 10 minutes.



Illustration 61

g02832442

Typical example

- Remove the engine oil level gauge to check the oil level. Maintain the oil level between the MIN mark and MAX mark on the engine oil level gauge. Do not fill the crankcase above the MAX mark.

Engine Oil Service Reset

NOTICE

Failure to perform a schedule oil and filter service with an engine oil service reset will trigger an engine derate.

The low oil warning lamp has two functions. The lamp on solid will indicate that the engine has low oil pressure. The lamp flashing will indicate the engine oil and filter **MUST** be changed and the engine oil service reset **MUST** be completed. The lamp will only flash with the key in the ON position, with the engine in operation the lamp will be extinguished.

Note: If the engine oil and filter have been changed before the warning lamp has started to flash, the engine oil service reset procedure **MUST** still be completed.

Some applications may have other methods to perform an engine oil service reset. For assistance with the engine oil service reset contact your Cat dealer, or your OEM.

Use one of the following procedures after the engine oil and filter have been changed to reset the flashing warning lamp:

Throttle Control Option

Note: Some application the maximum throttle position can before the throttle peddle has reached the stop. The actual maximum position of the throttle must be known before starting the procedure. With the known maximum position the middle position of the throttle can be calculated. The throttle must be positioned in the required positions for the prescribed period in order to perform an engine oil service reset.

- With the engine stopped. Turn the keyswitch to the ON position, and wait 15 seconds, but not more than 20 seconds. Go to step 2.
- Move the throttle to the maximum position for more than 15 seconds, but less than 20 seconds.
- Return throttle to zero position for more than 15 seconds, but less than 20 seconds.
- Move the throttle to the maximum position for more than 15 seconds, but less than 20 seconds.
- Return throttle to zero position for more than 15 seconds, but less than 20 seconds.
- Move the throttle to the middle position for more than 15 seconds, but less than 20 seconds. Return the throttle to zero position. The engine oil service reset procedure is complete.
- On completion of the sequence, the warning lamp will flash three times. Each flash will be for 1 second with a 1 second interval. This sequence of flashes indicates that the warning lamp has been reset and the engine can be started and operated normally.
- Turn the keyswitch to the OFF position.
- If the procedure has been interrupted before completion, turn the power off for 20 seconds before starting again.

Multi-State Switch Option

- Turn the keyswitch to the ON position, and wait 15 seconds, but not more than 20 seconds. Go to step 2.
- Turn the multi-state switch to position 1 for more than 15 seconds, but less than 20 seconds.
- Return the multi-state switch to position 0 for more than 15 seconds, but less than 20 seconds.
- Turn the multi-state switch to position 1 for more than 15 seconds, but less than 20 seconds.
- Return the multi-state switch to position 0 for more than 15 seconds, but less than 20 seconds

6. Turn the multi-state switch to position 1 for more than 15 seconds, but less than 20 seconds. Return the multi-state switch to position 0. The engine oil service reset procedure is complete.
7. On completion of the sequence, the warning lamp will flash three times. Each flash will be for 1 second with a 1 second interval. This sequence of flashes indicates that the warning lamp has been reset and the engine can be started and operated normally.
8. Turn the keyswitch to the OFF position.
9. If the procedure has been interrupted before completion, turn the power off for 20 seconds before starting again.

Electronic Technician (ET)

ET can be used to reset the oil service indicator. Connect ET and use the menu to reset the oil service reset procedure.

i04401341

Fan Clearance - Check

SMCS Code: 1356; 1359; 1360

There are different types of cooling systems. Refer to the OEM for information on clearance for the fan.

Ensure that the engine is stopped. Ensure that the battery disconnect switch is in the OFF position. Ensure that the cooling system is full. The clearance between the cover (1) and the fan (2) will require checking. The gap (A) between the edge of the cover and the tip of the fan blade must be checked in four equally spaced positions.

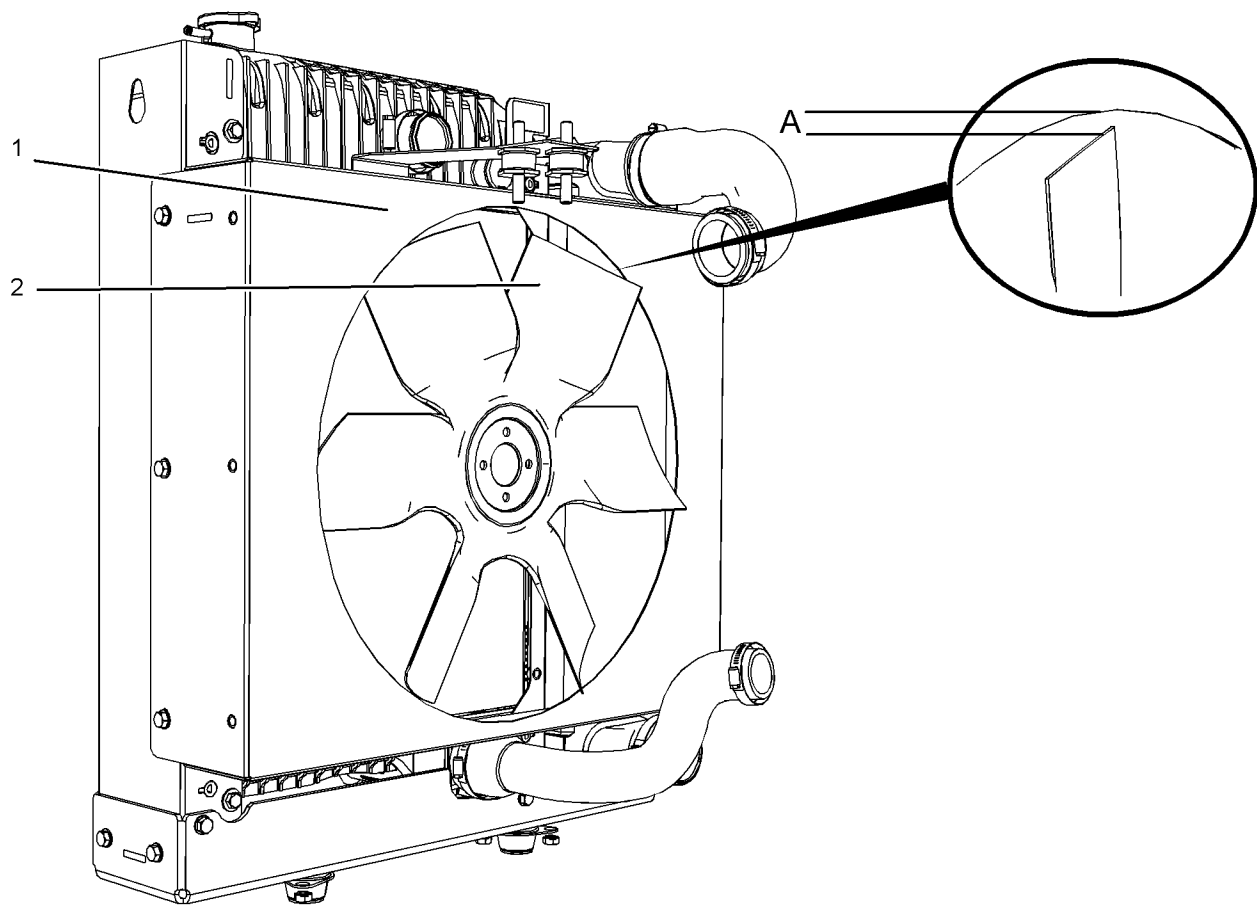

Illustration 62

g02585058

Typical example

Adjustment of the cover will change the clearance (gap) between the edge of the cover and the tip of the fan blade. Ensure that the cover is centralized to the fan.

The clearance (A) must be set to 10 ± 1 mm (0.39370 ± 0.03937 inch).

i04366913

Fuel System - Prime

SMCS Code: 1250-548; 1258-548

Note: Refer to Systems Operation, Testing, and Adjusting, "Cleanliness of Fuel System Components" for detailed information on the standards of cleanliness that must be observed during ALL work on the fuel system.

Ensure that all adjustments and repairs are performed by authorized personnel that have had the correct training.

NOTICE

Do not crank the engine continuously for more than 30 seconds. Allow the starting motor to cool for two minutes before cranking the engine again.

If air enters the fuel system, the air must be purged from the fuel system before the engine can be started. Air can enter the fuel system when the following events occur:

- The fuel tank is empty or the fuel tank has been partially drained.
- The low-pressure fuel lines are disconnected.
- A leak exists in the low-pressure fuel system.
- The fuel filter has been replaced.

Use the following procedures in order to remove air from the fuel system:

Maintenance Section
Fuel System Primary Filter (Water Separator) Element - Replace

1. Ensure that the fuel system is in working order.
Check that the fuel supply valve (if equipped) is in the "ON" position.
 2. Operate the hand priming pump. Count the number of operations of the pump. After approximately 80 depression of the pump stop.
- Note:** As the fuel system is primed, the pressure will increase within the fuel system and this increase in pressure can be felt during priming.
3. The fuel system should now be primed and the engine should be able to start.
 4. Operate the engine starter and crank the engine.
After the engine has started, operate the engine at low idle for a minimum of 5 minutes. Ensure that the fuel system is free from leaks.

Note: Operating the engine for this period will help ensure that the fuel system is free of air. **DO NOT loosen the high-pressure fuel lines in order to purge air from the fuel system. This procedure is not required.**

After the engine has stopped, you must wait for 10 minutes in order to allow the fuel pressure to be purged from the high-pressure fuel lines before any service or repair is performed on the engine fuel lines. If necessary, perform minor adjustments. Repair any leaks from the low-pressure fuel system and from the cooling, lubrication, or air systems. Replace any high-pressure fuel line that has leaked. Refer to Disassembly and Assembly Manual, "Fuel Injection Lines - Install".

If you inspect the engine in operation, always use the proper inspection procedure in order to avoid a fluid penetration hazard. Refer to Operation and Maintenance Manual, "General hazard Information".

If the engine will not start, refer to Troubleshooting, "Engine Cranks but will not Start".

i05326333

Fuel System Primary Filter (Water Separator) Element - Replace

SMCS Code: 1260-510-FQ; 1263-510-FQ

WARNING

Fuel leaked or spilled onto hot surfaces or electrical components can cause a fire. To help prevent possible injury, turn the start switch off when changing fuel filters or water separator elements. Clean up fuel spills immediately.

Note: Refer to Systems Operation, Testing, and Adjusting, "Cleanliness of Fuel System Components" for detailed information on the standards of cleanliness that must be observed during ALL work on the fuel system.

NOTICE

Ensure that the engine is stopped before any servicing or repair is performed.

Remove the Element

1. Turn the fuel supply valve (if equipped) to the OFF position before performing this maintenance.
2. Place a suitable container under the water separator in order to catch any fuel that might spill. Clean up any spilled fuel. Clean the outside body of the filter assembly.
3. Make a temporary Mark (A) across the filter before the assembly is removed.

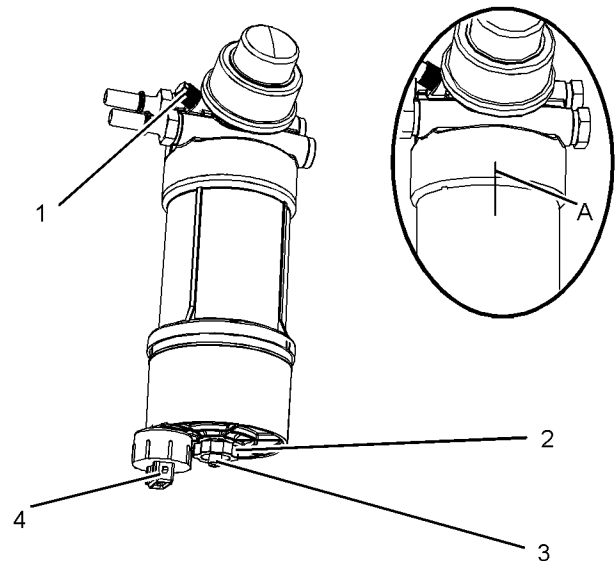

Illustration 63

g03374220

Typical example

4. Install a suitable tube onto drain (3). Open the drain valve (2). Rotate the drain valve counterclockwise. Two full turns are required. Loosen vent screw (1).

Note: Two complete rotations of the valve will release the valve from the filter element.

5. Allow the fuel to drain into the container. Remove the tube and install the valve into the filter element. Engage the threads of the valve into the filter element. Do not secure the valve.

6. Tighten the vent screw (1) securely . Remove the wiring harness from connection (4).

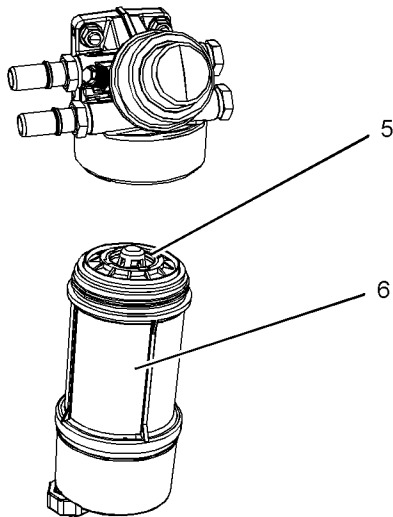

Illustration 64

g03374223

Typical example

7. Remove the filter bowl (6). Rotate the filter assembly counterclockwise in order to remove the filter assembly. Refer to your Cat dealer for the correct tool in order to remove the filter assembly.

8. Rotate the filter element counterclockwise and remove the filter element (5). Clean the filter bowl.

Install the Element

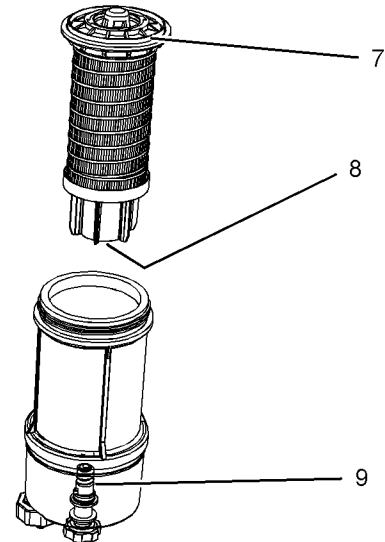

Illustration 65

g03374224

Typical example

1. Locate the thread in the filter element (8) onto the threads (9). Spin on the element. Do not tighten.
2. Lubricate the O ring seal (7) with clean engine oil. Do NOT fill the bowl with fuel before the assembly is installed.
3. Do not use a tool in order to install the filter assembly. Tighten the filter bowl (6) by hand. Install the filter bowl (6) and align with your temporary marks (A).
4. Tighten the valve (2) securely. Remove the container and dispose of the fuel in a safe place.

5. The secondary filter element must be replaced at the same time as the primary filter element. Refer to the Operation and Maintenance Manual , “Fuel System Filter - Replace”.

i05326334

Fuel System Primary Filter/ Water Separator - Drain

SMCS Code: 1260-543; 1263-543

WARNING

Fuel leaked or spilled onto hot surfaces or electrical components can cause a fire. To help prevent possible injury, turn the start switch off when changing fuel filters or water separator elements. Clean up fuel spills immediately.

NOTICE

Ensure that the engine is stopped before any servicing or repair is performed.

NOTICE

The water separator can be under suction during normal engine operation. Ensure that the drain valve is tightened securely to help prevent air from entering the fuel system.

1. Place a suitable container under the water separator in order to catch any fluid that might spill. Clean up any spilled fluid.
2. Ensure that the outer body of the filter assembly is clean and free from dirt.

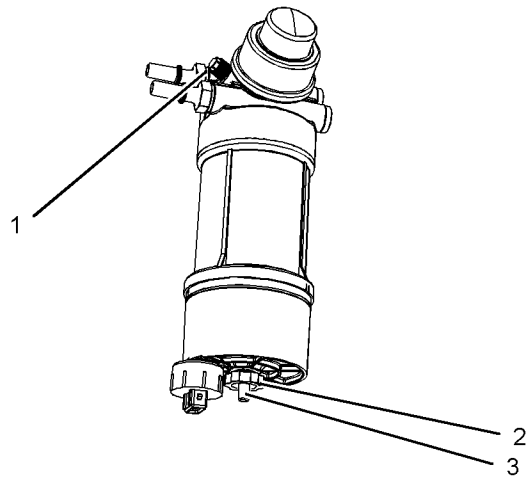

Illustration 66

g03374226

Typical example

3. Install a suitable tube onto drain (3). Open the drain valve (2). Rotate the drain valve counterclockwise. Two full turns are required. Loosen vent screw (1).

Note: Two complete rotations of the valve will release the valve from the filter element.

4. Allow the fluid to drain into the container.
5. Engage the threads of the valve into the filter element and tighten the drain valve by hand pressure only. Tighten vent screw securely.
6. Remove the tube and remove the container.

i04406165

Fuel System Secondary Filter - Replace

SMCS Code: 1261-510-SE

WARNING

Fuel leaked or spilled onto hot surfaces or electrical components can cause a fire. To help prevent possible injury, turn the start switch off when changing fuel filters or water separator elements. Clean up fuel spills immediately.

NOTICE

Ensure that the engine is stopped before any servicing or repair is performed.

Refer to **Systems Operation, Testing, and Adjusting, "Cleanliness of Fuel System Components"** for detailed information on the standards of cleanliness that must be observed during ALL work on the fuel system.

Remove the Element

1. Turn the fuel supply valve (if equipped) to the OFF position before performing this maintenance.
2. Place a suitable container under the fuel filter in order to catch any fuel that might spill. Clean up any spilled fuel. Clean the outside body of the filter assembly.

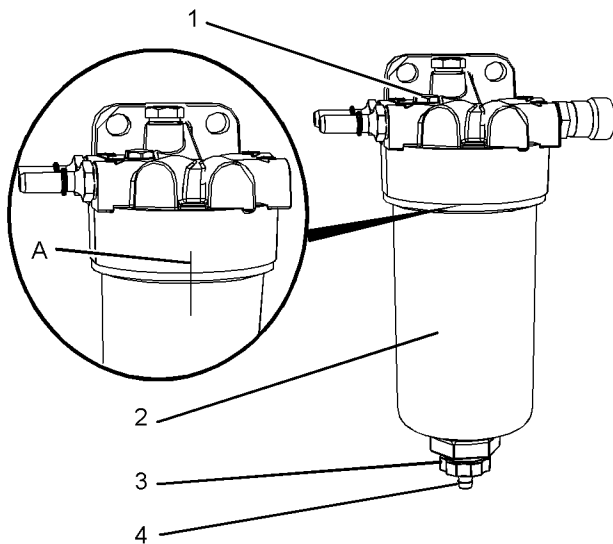

Illustration 67

g02522536

Typical example

3. Make a temporary Mark (A) across the filter before the assembly is removed. Install a suitable tube onto drain (4). Open the drain valve (3). Rotate the drain valve counterclockwise. Two full turns are required. Loosen vent screw (1).

Note: Two complete rotations of the valve will release the valve from the filter element.

4. Allow the fuel to drain into the container. Remove the tube and install the valve into the filter element. Engage the threads of the valve into the filter element. Do not secure the valve.
5. Tighten the vent screw (1) securely.
6. Remove the filter bowl (2). Rotate the filter assembly counterclockwise in order to remove the assembly. Remove the filter bowl, refer to your Cat dealer for the correct tool.

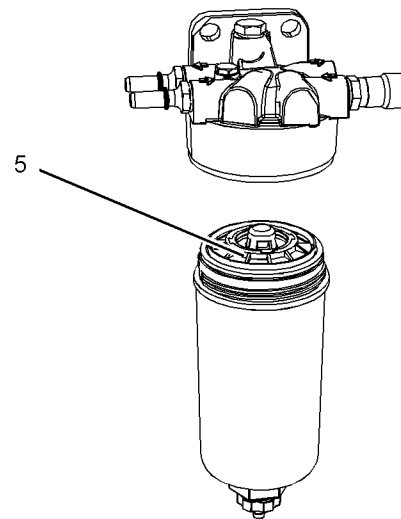

Illustration 68

g02522538

Typical example

7. Rotate the filter element counterclockwise and remove the filter element (5). Clean the filter bowl.

Install the Element

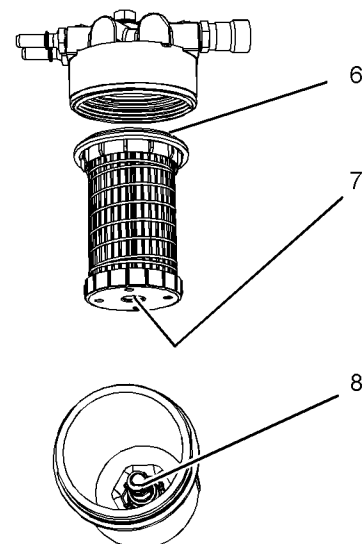

Illustration 69

g02522540

Typical example

1. Locate the thread in the filter element (7) onto the threads (8). Spin on the element. Do not tighten.

2. Lubricate the O ring seal (6) with clean engine oil. Do NOT fill the filter bowl (2) with fuel before the filter assembly is installed.
3. Do NOT use a tool in order to install the filter assembly. Tighten the assembly by hand. Install the filter bowl (2) and align with your temporary Marks.
4. Tighten the drain valve (3). Turn the fuel supply valve to the ON position.
5. The Primary filter element must be replaced at the same time as the secondary filter element. Refer to the Operation and Maintenance Manual , “Fuel System Primary Filter (Water Separator) Element - Replace”.
6. Prime the fuel system. Refer to the Operation and Maintenance Manual, “Fuel System - Prime” for more information.

i02348492

Fuel Tank Water and Sediment - Drain

SMCS Code: 1273-543-M&S

NOTICE

Care must be taken to ensure that fluids are contained during performance of inspection, maintenance, testing, adjusting and repair of the product. Be prepared to collect the fluid with suitable containers before opening any compartment or disassembling any component containing fluids.

Dispose of all fluids according to local regulations and mandates.

Fuel Tank

Fuel quality is critical to the performance and to the service life of the engine. Water in the fuel can cause excessive wear to the fuel system.

Water can be introduced into the fuel tank when the fuel tank is being filled.

Condensation occurs during the heating and cooling of fuel. The condensation occurs as the fuel passes through the fuel system and the fuel returns to the fuel tank. This causes water to accumulate in fuel tanks. Draining the fuel tank regularly and obtaining fuel from reliable sources can help to eliminate water in the fuel.

Drain the Water and the Sediment

Fuel tanks should contain some provision for draining water and draining sediment from the bottom of the fuel tanks.

Open the drain valve on the bottom of the fuel tank in order to drain the water and the sediment. Close the drain valve.

Check the fuel daily. Allow five minutes after the fuel tank has been filled before draining water and sediment from the fuel tank.

Fill the fuel tank after operating the engine in order to drive out moist air. This will help prevent condensation. Do not fill the tank to the top. The fuel expands as the fuel gets warm. The tank may overflow.

Some fuel tanks use supply pipes that allow water and sediment to settle below the end of the fuel supply pipe. Some fuel tanks use supply lines that take fuel directly from the bottom of the tank. If the engine is equipped with this system, regular maintenance of the fuel system filter is important.

Fuel Storage Tanks

Drain the water and the sediment from the fuel storage tank at the following intervals:

- Weekly
- Service intervals
- Refill of the tank

This will help prevent water or sediment from being pumped from the storage tank into the engine fuel tank.

If a bulk storage tank has been refilled or moved recently, allow adequate time for the sediment to settle before filling the engine fuel tank. Internal baffles in the bulk storage tank will also help trap sediment. Filtering fuel that is pumped from the storage tank helps to ensure the quality of the fuel. When possible, water separators should be used.

i02518232

Hoses and Clamps - Inspect/ Replace

SMCS Code: 7554-510; 7554-040

WARNING

Contact with high pressure fuel may cause fluid penetration and burn hazards. High pressure fuel spray may cause a fire hazard. Failure to follow these inspection, maintenance and service instructions may cause personal injury or death.

If you inspect the engine in operation, always use the proper inspection procedure in order to avoid a fluid penetration hazard. Refer to Operation and Maintenance Manual, “General hazard Information”.

Inspect all hoses for leaks that are caused by the following conditions:

- Cracking
- Softness
- Loose clamps

Replace hoses that are cracked or soft. Tighten any loose clamps.

Check for the following conditions:

- End fittings that are damaged or leaking
- Outer covering that is chafed or cut
- Exposed wire that is used for reinforcement
- Outer covering that is ballooning locally
- Flexible part of the hose that is kinked or crushed
- Armoring that is embedded in the outer covering

A constant torque hose clamp can be used in place of any standard hose clamp. Ensure that the constant torque hose clamp is the same size as the standard clamp.

Due to extreme temperature changes, the hose will harden. Hardening of the hoses will cause hose clamps to loosen. This can result in leaks. A constant torque hose clamp will help to prevent loose hose clamps.

Each installation application can be different. The differences depend on the following factors:

- Type of hose
- Type of fitting material
- Anticipated expansion and contraction of the hose
- Anticipated expansion and contraction of the fittings

Replace the Hoses and the Clamps

Refer to the OEM information for further information on removing and replacing fuel hoses (if equipped).

The following text describes a typical method of replacing coolant hoses. Refer to the OEM information for further information on the coolant system and the hoses for the coolant system.

WARNING

Pressurized System: Hot coolant can cause serious burns. To open the cooling system filler cap, stop the engine and wait until the cooling system components are cool. Loosen the cooling system pressure cap slowly in order to relieve the pressure.

1. Stop the engine. Allow the engine to cool.
2. Loosen the cooling system filler cap slowly in order to relieve any pressure. Remove the cooling system filler cap.

Note: Drain the coolant into a suitable, clean container. The coolant can be reused.

3. Drain the coolant from the cooling system to a level that is below the hose that is being replaced.
4. Remove the hose clamps.
5. Disconnect the old hose.
6. Replace the old hose with a new hose.
7. Install the hose clamps with a torque wrench.

Note: For the correct coolant, see this Operation and Maintenance Manual, "Fluid Recommendations".

8. Refill the cooling system. Refer to the OEM information for further information on refilling the cooling system.
9. Clean the cooling system filler cap. Inspect the cooling system filler cap's seals. Replace the cooling system filler cap if the seals are damaged. Install the cooling system filler cap.
10. Start the engine. Inspect the cooling system for leaks.

i04224312

Overhaul Considerations

SMCS Code: 7595-043

Reduced hours of operation at full load will result in a lower average power demand. A decreased average power demand should increase both the engine service life and the overhaul interval.

The need for an overhaul is indicated by increased fuel consumption, increased oil consumption, excessive engine blowby, and reduced power. Arctic temperatures, extreme high temperatures, corrosive environments, or extreme dusty conditions contribute to premature wear and the need for an overhaul.

The following factors are important when a decision is being made on the proper time for an engine overhaul:

- The need for preventive maintenance
- The quality of the fuel that is being used
- The operating conditions
- The results of the S·O·S analysis

Oil Consumption as an Overhaul Indicator

Oil consumption, fuel consumption, and maintenance information can be used to estimate the total operating cost for your Caterpillar engine. Oil consumption can also be used to estimate the required capacity of a makeup oil tank that is suitable for the maintenance intervals.

Oil consumption is in proportion to the percentage of the rated engine load. As the percentage of the engine load is increased, the amount of oil that is consumed per hour also increases.

The oil consumption rate (brake-specific oil consumption) is measured in grams per kW/h (lb per bhp). The brake-specific oil consumption (BSOC) depends on the engine load. Consult your Caterpillar dealer for assistance in determining the typical oil consumption rate for your engine.

When an engine's oil consumption has risen to three times the original oil consumption rate due to normal wear, an engine overhaul should be scheduled. There may be a corresponding increase in blowby and a slight increase in fuel consumption.

Overhaul Options

Before Failure Overhaul

A planned overhaul before failure may be the best value for the following reasons:

- Costly unplanned downtime can be avoided.
- Many original parts can be reused according to the standards for reusable parts.
- The engine's service life can be extended without the risk of a major catastrophe due to engine failure.
- The best cost/value relationship per hour of extended life can be attained.

After Failure Overhaul

If a major engine failure occurs and the engine must be removed, many options are available. An overhaul should be performed if the engine block or the crankshaft needs to be repaired.

If the engine block is repairable and/or the crankshaft is repairable, the overhaul cost will be less than the cost of a new engine with a similar exchange core.

This lower cost can be attributed to three aspects:

- Specially designed Caterpillar engine features
- Caterpillar dealer exchange components
- Caterpillar Inc. remanufactured exchange components

Overhaul Recommendation

To minimize downtime, Caterpillar Inc. recommends a scheduled engine overhaul by your Caterpillar dealer before the engine fails. This process will provide you with the best cost/value relationship.

Note: Overhaul programs vary according to the engine application and according to the dealer that performs the overhaul. Consult your Caterpillar dealer for specific information about the available overhaul programs and about overhaul services for extending the engine life.

Aftertreatment

The aftertreatment system can be expected to function properly for the useful life of the engine (emissions durability period), as defined by regulation, subject to prescribed maintenance requirements being followed.

Rebuild or Exchange

If an overhaul is performed without overhaul service from your Caterpillar dealer, be aware of the following maintenance recommendations.

Cylinder Head Assembly, Oil Pump, and Fuel Transfer Pump

These components should be inspected according to the instructions that are found in various Caterpillar reusability publications. The Special Publication, SEBF8029 lists the reusability publications that are needed for inspecting the engine parts.

If the parts comply with the established inspection specifications that are expressed in the reusable parts guideline, the parts should be reused.

Parts that are not within the established inspection specifications should be dealt with in one of the following manners:

- Salvaging
- Repairing
- Replacing

Using out-of-spec parts can result in the following problems:

- Unscheduled downtime
- Costly repairs
- Damage to other engine parts
- Reduced engine efficiency
- Increased fuel consumption

Reduced engine efficiency and increased fuel consumption translates into higher operating costs. Therefore, Caterpillar Inc. recommends repairing out-of-spec parts or replacing out-of-spec parts.

Inspection and/or Replacement

Crankshaft Bearings Crankshaft Seals and Pistons

The following components may not last until the second overhaul.

- Thrust bearings
- Main bearings
- Rod bearings
- Crankshaft seals
- Piston assembly

Caterpillar Inc. recommends the installation of new parts at each overhaul period.

Inspect these parts while the engine is disassembled for an overhaul.

Inspect the crankshaft for any of the following conditions:

- Deflection
- Damage to the journals
- Bearing material that has seized to the journals

Check the journal taper and the profile of the crankshaft journals. If the wear patterns on the rod bearing or the main bearing show a problem, the crankshaft will need to be measured with specialist equipment.

Inspect the camshaft for damage to the journals and to the lobes.

Note: If the camshaft is removed for any reason, use the magnetic particle inspection process to check for cracks in the camshaft.

Inspect the following components for signs of wear or for signs of scuffing:

- Camshaft bearings
- Lifters

Caterpillar Inc. recommends replacing the crankshaft vibration damper.

Oil Cooler Core

During an overhaul, Caterpillar Inc. recommends the removal of the oil cooler core. Clean the oil cooler core. Then, pressure test the oil cooler core.

NOTICE

Do not use caustic cleaners to clean the core.

Caustic cleaners can attack the internal metals of the core and cause leakage.

Note: Use this cleaning procedure to clean the oil cooler core.

1. Remove the oil cooler core.
2. Remove any debris from the oil cooler core. To remove debris from the oil cooler core, turn the oil cooler core onto one end.
3. Flush the oil cooler core internally with cleaner in order to loosen foreign substances. This flushing will also help to remove oil from the oil cooler core.

Note: Caterpillar Inc. recommends the use of Hydrosolv Liquid Cleaners. Table 10 lists the Hydrosolv Liquid Cleaners that are available from your Caterpillar dealer.

Table 10

Hydrosolv Liquid Cleaners		
Part Number	Description	Size
1U-8812	Hydrosolv4165	4 L (1 US gallon)
1U-5490		19 L (5 US gallon)
8T-7570		208 L (55 US gallon)
1U-8804	Hydrosolv100	4 L (1 US gallon)
1U-5492		19 L (5 US gallon)
8T-5571		208 L (55 US gallon)

4. Use steam to clean the oil cooler core. The steam will remove any remaining residue from the cleaner. Flush the fins of the oil cooler core. Remove any other trapped debris.

5. Wash the oil cooler core with hot, soapy water. Rinse the oil cooler core thoroughly with clean water.

WARNING

Personal injury can result from air pressure.

Personal injury can result without following proper procedure. When using pressure air, wear a protective face shield and protective clothing.

Maximum air pressure at the nozzle must be less than 205 kPa (30 psi) for cleaning purposes.

6. Dry the oil cooler core with compressed air. Direct the air in the reverse direction of the normal flow.
7. Inspect the components in order to ensure cleanliness. The oil cooler core should be pressure tested. Repair the oil cooler core, if necessary. Install the oil cooler core.

For more information about cleaning the cores, consult your Caterpillar dealer.

Obtain Coolant Analysis

The concentration of supplemental coolant additive (SCA) should be checked regularly with test kits or with S·O·S Coolant Analysis (Level 1). Further coolant analysis is recommended when the engine is overhauled.

For example, considerable deposits are found in the water jacket areas on the external cooling system, but the concentrations of coolant additives were carefully maintained. The coolant probably contained minerals that were deposited on the engine over time.

A coolant analysis can be conducted in order to verify the condition of the water that is being used in the cooling system. A full water analysis can be obtained by consulting your local water utility company or an agricultural agent. Private laboratories are also available for water analysis.

Caterpillar Inc. recommends an S·O·S Coolant Analysis (Level 2).

S·O·S Coolant Analysis (Level 2)

An S·O·S Coolant Analysis (Level 2) is a comprehensive coolant analysis which completely analyzes the coolant and the effects on the cooling system. An S·O·S Coolant Analysis (Level 2) provides the following information:

- Complete S·O·S Coolant Analysis (Level 1)
- Visual inspection of properties
- Identification of metal corrosion

- Identification of contaminants
- Identification of built up impurities (corrosion and scale)

S·O·S Coolant Analysis (Level 2) provides a report of the results of both the analysis and the maintenance recommendations.

For more information about coolant analysis, see your Caterpillar dealer.

i05324852

Oxygen Sensor - Replace

SMCS Code: 1096-510

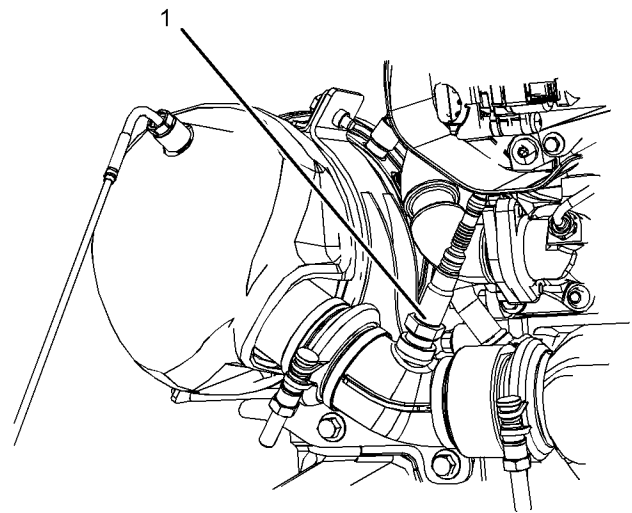

Illustration 70

g03373217

Typical example

The oxygen sensor (1) must be replaced at 3000 hours. Refer to the Disassembly and Assembly, "Oxygen Sensor - Remove and Install" for the procedure.

The electronic service tool will be required in order to perform a reset after a new oxygen sensor is installed.

i04020194

Radiator - Clean

SMCS Code: 1353-070

Note: Adjust the frequency of cleaning according to the effects of the operating environment.

Inspect the radiator for these items: damaged fins, corrosion, dirt, grease, insects, leaves, oil and other debris. Clean the radiator, if necessary.

⚠ WARNING

Personal injury can result from air pressure.

Personal injury can result without following proper procedure. When using pressure air, wear a protective face shield and protective clothing.

The maximum air pressure for cleaning purposes must be reduced to 205 kPa (30 psi) when the air nozzle is deadheaded.

Pressurized air is the preferred method for removing loose debris. Direct the air in the opposite direction of the air flow. Hold the nozzle approximately 6 mm (0.25 inch) away from the fins. Slowly move the air nozzle in a direction that is parallel with the tubes. This movement will remove debris that is between the tubes.

Pressurized water may also be used for cleaning. The maximum water pressure for cleaning purposes must be less than 275 kPa (40 psi). Use pressurized water in order to soften mud. Clean the core from both sides.

Use a degreaser and steam for removal of oil and grease. Clean both sides of the core. Wash the core with detergent and hot water. Thoroughly rinse the core with clean water.

After cleaning, start the engine and accelerate the engine to high idle rpm. This procedure will help in the removal of debris and drying of the core. Stop the engine. Use a light bulb behind the core in order to inspect the core for cleanliness. Repeat the cleaning, if necessary.

Inspect the fins for damage. Bent fins may be opened with a "comb". Inspect these items for good condition: welds, mounting brackets, air lines, connections, clamps and seals. Make repairs, if necessary.

i03639888

Radiator Pressure Cap - Clean/Replace

SMCS Code: 1353-070-CAP; 1353-510-CAP; 1353-070-Z2; 1353-510-Z2; 1353; 1353-Z2; 7528

⚠ WARNING

Pressurized System: Hot coolant can cause serious burns. To open the cooling system filler cap, stop the engine and wait until the cooling system components are cool. Loosen the cooling system pressure cap slowly in order to relieve the pressure.

NOTICE

When any servicing or repair of the engine cooling system is performed the procedure must be performed with the engine on level ground. This will allow you to accurately check the coolant level. This will also help in avoiding the risk of introducing an air lock into the coolant system.

1. Stop the engine and allow the engine to cool. Loosen the cooling system filler cap slowly in order to relieve any pressure. Remove the radiator pressure cap.
2. Check coolant level. Refer to Operation and Maintenance Manual, "Cooling System Coolant Level - Check".
3. Install new radiator pressure cap.

i02348493

Starting Motor - Inspect

SMCS Code: 1451-040; 1453-040

Caterpillar recommends a scheduled inspection of the starting motor. If the starting motor fails, the engine may not start in an emergency situation.

Check the starting motor for correct operation. Check the electrical connections and clean the electrical connections. Refer to the Systems Operation, Testing and Adjusting Manual, "Electric Starting System - Test" for more information on the checking procedure and for specifications or consult your Caterpillar dealer for assistance.

i04407666

Turbocharger - Inspect

SMCS Code: 1052-040

⚠ WARNING

Hot engine components can cause injury from burns. Before performing maintenance on the engine, allow the engine and the components to cool.

NOTICE

Turbocharger bearing failures can cause large quantities of oil to enter the air intake and exhaust systems. Loss of engine lubricant can result in serious engine damage.

Minor leakage of oil into a turbocharger under extended low idle operation should not cause problems as long as a turbocharger bearing failure has not occurred.

When a turbocharger bearing failure is accompanied by a significant engine performance loss (exhaust smoke or engine rpm up at no load), do not continue engine operation until the turbocharger is renewed.

A visual inspection of the turbocharger can minimize unscheduled downtime. A visual inspection of the turbocharger can also reduce the chance of potential damage to other engine parts. Do not inspect the engine with the engine in operation.

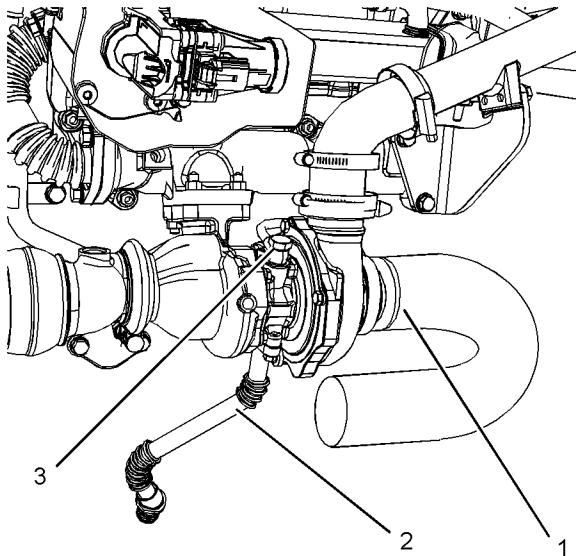

Illustration 71

g02603804

Typical example

1. Ensure that the turbocharger is clean and free from dirt before removing components for inspection.
2. Remove the air intake pipe (1). Visually inspect the piping for the presence of oil. A small amount oil will be expected, this oil is due to the breather system design. Clean the interior of the pipe in order to prevent dirt from entering during reassembly.

3. Check for obvious heat discoloration of the turbocharger. Check for any loose bolts or any missing bolts. Check for damage to the oil supply line (3) and the oil drain line (2). Check for cracks in the housing of the turbocharger. Ensure that the compressor wheel can rotate freely. Check that there are no visual signs of damage to the compressor wheel.

4. Check for the presence of oil. If oil is leaking from the back side of the compressor wheel, there is a possibility of a failed turbocharger oil seal.

The presence of oil may be the result of extended engine operation at low idle. The presence of oil may also be the result of a restriction of the line for the intake air (clogged air filters). A restriction can cause the turbocharger to slobber.

5. Install the air intake pipe to the turbocharger housing. Ensure that all clamps are installed correctly and that all clamps are tightened securely. For more information, refer to Systems Operation, Testing, and Adjusting, "Turbocharger - Inspect".

i04406814

Walk-Around Inspection

SMCS Code: 1000-040

Inspect the Engine for Leaks and for Loose Connections

A walk-around inspection should only take a few minutes. When the time is taken to perform these checks, costly repairs and accidents can be avoided.

For maximum engine service life, make a thorough inspection of the engine compartment before starting the engine. Look for items such as oil leaks or coolant leaks, loose bolts, worn belts, loose connections, and trash buildup. Make repairs, as needed:

- The guards must be in the correct place. Repair damaged guards or replace missing guards.
- Wipe all caps and plugs before the engine is serviced in order to reduce the chance of system contamination.

NOTICE

For any type of leak (coolant, lube, or fuel) clean up the fluid. If leaking is observed, find the source and correct the leak. If leaking is suspected, check the fluid levels more often than recommended until the leak is found or fixed, or until the suspicion of a leak is proved to be unwarranted.

NOTICE

Accumulated grease and/or oil on an engine is a fire hazard. Remove the accumulated grease and oil. Refer to this Operation and Maintenance Manual, "Engine - Clean" for more information.

- Ensure that the cooling system hoses are correctly clamped and that the cooling system hoses are tight. Check for leaks. Check the condition of all pipes.
- Inspect the water pump for coolant leaks.

Note: The water pump seal is lubricated by the coolant in the cooling system. A small amount of leakage is normal and can occur as the engine cools down and the parts contract.

Excessive coolant leakage may indicate the need to replace the water pump. Remove the water pump. Refer to Disassembly and Assembly, "Water Pump - Remove and Install". For more information, consult your Caterpillar dealer.

- Inspect the lubrication system for leaks at the front crankshaft seal, the rear crankshaft seal, the oil pan, the oil filters, and the rocker cover.
- Inspect the piping for the air intake system and the elbows for cracks and for loose clamps. Ensure that hoses and tubes are not contacting other hoses, tubes, wiring harnesses, etc.
- Ensure that the areas around the rotating parts are clear.
- Inspect the alternator belts and any accessory drive belts for cracks, breaks, or other damage.
- Inspect the wiring harness for damage.

Belts for multiple groove pulleys must be replaced as matched sets. If only one belt is replaced, the belt will carry more load than the belts that are not replaced. The older belts are stretched. The additional load on the new belt could cause the belt to break.

High Pressure Fuel Lines

 **WARNING**

Contact with high pressure fuel may cause fluid penetration and burn hazards. High pressure fuel spray may cause a fire hazard. Failure to follow these inspection, maintenance and service instructions may cause personal injury or death.

After the engine has stopped, you must wait for 10 minutes in order to allow the fuel pressure to be purged from the high-pressure fuel lines before any service or repair is performed on the engine fuel lines. If necessary, perform minor adjustments. Repair any leaks from the low-pressure fuel system and from the cooling, lubrication, or air systems. Replace any high-pressure fuel line that has leaked. Refer to Disassembly and Assembly Manual, "Fuel Injection Lines - Install".

If you inspect the engine in operation, always use the proper inspection procedure in order to avoid a fluid penetration hazard. Refer to Operation and Maintenance Manual, "General hazard Information".

Visually inspect the high-pressure fuel lines for damage or signs of fuel leakage. Replace any damaged high-pressure fuel lines or high-pressure fuel lines that have leaked.

Ensure that all clips on the high-pressure fuel lines are in place and that the clips are not loose.

- Inspect the rest of the fuel system for leaks. Look for loose fuel line clamps.
- Drain the water and the sediment from the fuel tank on a daily basis in order to ensure that only clean fuel enters the fuel system.
- Inspect the wiring and the wiring harnesses for loose connections and for worn wires or frayed wires. Check for any loose tie-wraps or missing tie-wraps.
- Inspect the ground strap for a good connection and for good condition.
- Disconnect any battery chargers that are not protected against the current drain of the starting motor. Check the condition and the electrolyte level of the batteries, unless the engine is equipped with a maintenance free battery.
- Check the condition of the gauges. Replace any gauges that are cracked. Replace any gauge that cannot be calibrated.

i04406817

Water Pump - Inspect

SMCS Code: 1361-040

A failed water pump may cause severe engine overheating problems that could result in the following conditions:

- Cracks in the cylinder head
- A piston seizure
- Other potential damage to the engine

Maintenance Section
Water Pump - Inspect

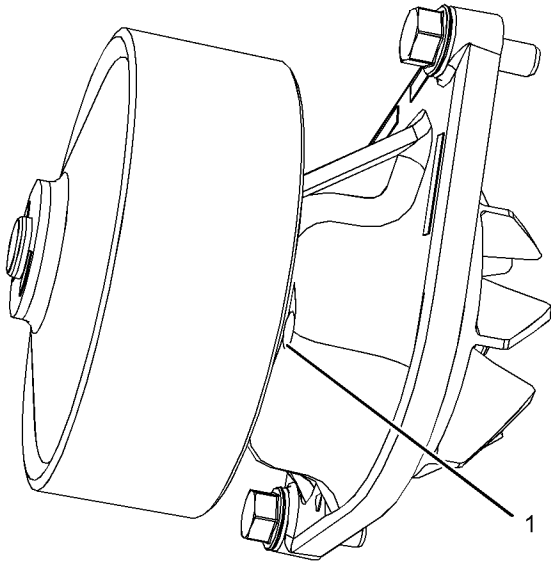

Illustration 72

g02601196

Typical example

(1) Weep hole

Note: The water pump seals are lubricated by the coolant in the cooling system.

Visually inspect the water pump for leaks.

Note: If engine coolant enters the engine lubricating system, the lubricating oil and the engine oil filter must be replaced. Draining will remove any contaminate and will prevent any irregular oil samples.

In order to install a new water pump, refer to the Disassembly and Assembly Manual, "Water Pump - Remove and Install".

Warranty Section

Warranty Information

i06044323

Emissions Warranty Information

SMCS Code: 1000

The certifying engine manufacturer warrants to the ultimate purchaser and each subsequent purchaser that:

1. New non-road diesel engines and stationary diesel engines less than 10 liters per cylinder (including Tier 1 and Tier 2 marine engines < 37 kW, but excluding locomotive and other marine engines) operated and serviced in the United States and Canada, including all parts of their emission control systems (“emission related components”), are:
 - a. Designed, built, and equipped so as to conform, at the time of sale, with applicable emission standards prescribed by the United States Environmental Protection Agency (EPA) by way of regulation.
 - b. Free from defects in materials and workmanship in emission-related components that can cause the engine to fail to conform to applicable emission standards for the warranty period.
2. New non-road diesel engines (including Tier 1 and Tier 2 marine propulsion engines < 37 kW and Tier 1 through Tier 4 marine auxiliary engines < 37 kW, but excluding locomotive and other marine engines) operated and serviced in the state of California, including all parts of their emission control systems (“emission related components”), are:
 - a. Designed, built, and equipped so as to conform, at the time of sale, to all applicable regulations adopted by the California Air Resources Board (ARB).
 - b. Free from defects in materials and workmanship which cause the failure of an emission-related component to be identical in all material respects to the component as described in the engine manufacturer's application for certification for the warranty period.

3. New non-road diesel engines installed in construction machines conforming to the South Korean regulations for construction machines manufactured after January 1, 2015, and operated and serviced in South Korea, including all parts of their emission control systems (“emission related components”), are:
 - a. Designed, built, and equipped so as to conform, at the time of sale, with applicable emission standards prescribed in the Enforcement Rule of the Clean Air Conservation Act promulgated by South Korea MOE.
 - b. Free from defects in materials and workmanship in emission-related components that can cause the engine to fail to conform to applicable emission standards for the warranty period.

The aftertreatment system can be expected to function properly for the lifetime of the engine (emissions durability period) subject to prescribed maintenance requirements being followed.

A detailed explanation of the Emission Control Warranty that is applicable to new non-road and stationary diesel engines, including the components covered and the warranty period, is found in a supplemental Special Publication. Consult your authorized Cat dealer to determine if your engine is subject to an Emission Control Warranty and to obtain a copy of the applicable Special Publication.

Reference Information Section

Engine Ratings

i04406857

Engine Rating Conditions

SMCS Code: 1000

Ensure that you know the use of the engine so that the rating will match the operating profile. The proper rating selection is also important so that the customers perception of price and value is realized.

In selecting a rating for a specific application, the most important consideration is the time that is spent at full throttle. The rating definitions identify the percent of time at full throttle. The definitions also identify the corresponding times below rated rpm.

Note: For an exact determination of the appropriate rating, follow the OEM specifications or consult your Cat dealer.

There are five ratings from A to E. The rating for the C3.4B industrial engine is C.

C – Intermittent service with maximum power and/or speed are cyclic. The engine at full load should not exceed 50 percent of the duty cycle.

NOTICE

Operating engines above the rating definitions can result in shorter service life before overhaul.

i04650089

Engine Rating Definitions

SMCS Code: 1000

All engine ratings are in compliance with the following standard ambient air conditions of "ISO14396:2002":

- 100 kPa (29.3 Inches Hg)
- 30 percent relative humidity
- A temperature of 25 °C (77 °F)

The engine ratings are based on the following fuel specifications:

- The Low Heat Value (LHV) of the fuel at 29 °C (84.2 °F) at 42780 kJ/kg (18390 Btu/lb)
- Specific gravity of .833 - 837 at 15 °C (60 °F)

The engine ratings are gross output ratings.

Gross Output Ratings – The total output capability of the engine that is equipped with standard accessories.

Standard accessories include the following components:

- Oil pumps
- Fuel pumps
- Water pumps

Subtract the power that is required to drive auxiliary components from the gross output. This process will produce the net power that is available for the external load (flywheel).

Customer Service

i03996951

Customer Assistance

SMCS Code: 1000; 4450

USA and Canada

When a problem arises concerning the operation or the service of an engine, the problem will normally be managed by the dealer in your area.

Outside of the USA and of Canada

If a problem arises outside the USA and outside Canada, and if the problem cannot be resolved at the dealer level, consult the appropriate Caterpillar office.

Latin America, Mexico, Carribean
Caterpillar Americas Co.
701 Waterford Way, Suite 200
Miami, FL 33126-4670
USA
Phone: 305-476-6800
Fax: 305-476-6801

Europe, Africa, and Middle East
Caterpillar Overseas S.A.
76 Route de Frontenex
P.O. Box 6000
CH-1211 Geneva 6
Switzerland
Phone: 22-849-4444
Fax: 22-849-4544

Far East
Caterpillar Asia Pte. Ltd.
7 Tractor Road
Jurong, Singapore 627968
Republic of Singapore
Phone: 65-662-8333
Fax: 65-662-8302

China
Caterpillar China Ltd.
37/F., The Lee Gardens
33 Hysan Avenue
Causeway Bay
G.P.O. Box 3069
Hong Kong
Phone: 852-2848-0333
Fax: 852-2848-0440

Japan
Shin Caterpillar Mitsubishi Ltd.
SBS Tower
10-1, Yoga 4-Chome
Setagaya-Ku, Tokyo 158-8530
Japan
Phone: 81-3-5717-1150
Fax: 81-3-5717-1177

Japan
Caterpillar Power Systems, Inc.
SBS Tower (14th floor)
4-10-1, Yoga
Setagaya-Ku, Tokyo 158-0097
Phone: 81-3-5797-4300
Fax: 81-3-5797-4359

Australia and New Zealand
Caterpillar of Australia Ltd.
1 Caterpillar Drive
Private Mail Bag 4
Tullamarine, Victoria 3043
Australia
Phone: 03-9953-9333
Fax: 03-9335-3366

i03655027

Ordering Replacement Parts

SMCS Code: 4450; 7567

WARNING

When replacement parts are required for this product Caterpillar recommends using Caterpillar replacement parts or parts with equivalent specifications including, but not limited to, physical dimensions, type, strength and material.

Failure to heed this warning can lead to premature failures, product damage, personal injury or death.

Quality Caterpillar replacement parts are available from Caterpillar dealers throughout the world. Caterpillar dealers' parts inventories are up-to-date. The parts stocks include all of the parts that are normally needed to protect your Caterpillar engine investment.

When you order parts, please specify the following information:

- When a Caterpillar engine requires maintenance and/or repair, provide the dealer with all the information that is stamped on the Information Plate. Refer to this Operation and Maintenance Manual, "Plate Locations and Film Locations".
- Part number
- Part name

Reference Information Section
Ordering Replacement Parts

- Quantity

If there is a question concerning the part number, please provide your dealer with a complete description of the needed item.

Discuss the problem with the dealer. Inform the dealer about the conditions of the problem and the nature of the problem. Inform the dealer about when the problem occurs. This will help the dealer in troubleshooting the problem and solving the problem faster.

Reference Materials

i05264255

Maintenance Records

SMCS Code: 1000; 4450

Caterpillar Inc. recommends the retention of accurate maintenance records. Accurate maintenance records can be used for the following purposes:

- Determine operating costs.
- Establish maintenance schedules for other engines that are operated in the same environment.
- Show compliance with the required maintenance practices and maintenance intervals.

Maintenance records can be used for various other business decisions that are related to engine maintenance.

Maintenance records are a key element of a maintenance program that is managed. Accurate maintenance records can help your Cat dealer to fine-tune the recommended maintenance intervals in order to meet the specific operating situation. This should result in a lower engine operating cost.

Records should be kept for the following items:

Fuel Consumption – A record of fuel consumption is essential in order to determine when the load sensitive components should be inspected or repaired. Fuel consumption also determines overhaul intervals.

Service Hours – A record of service hours is essential to determine when the speed sensitive components should be inspected or repaired.

Documents – These items should be easy to obtain, and these items should be kept in the engine history file. All of the documents should show this information: date, service hours, fuel consumption, unit number and engine serial number. The following types of documents should be kept as proof of maintenance or repair for warranty:

Keep the following types of documents as proof of maintenance for warranty. Also, keep these types of documents as proof of repair for warranty:

- Dealer work orders and itemized bills
- Owner repair costs
- Owner receipts
- Maintenance log

i04406878

Reference Material

SMCS Code: 1000; 4450

The following literature can be obtained through any Caterpillar dealer.

Lubricants

- Special Publication, PEHP0002, "Data Sheet - Molybdenum (MPGM) Grease"
- Special Publication, NEHP6015, "Data Sheet - Caterpillar High Speed Bearing Grease"
- Special Publication, SEBD0640, "Oil and Your Engine"
- Operation and Maintenance Manual, SEBU5898, "Cold Weather Recommendations"
- Operation and Maintenance Manual, SEBU6251, "Caterpillar Commercial Diesel Engine Fluids Recommendations"
- Special Publication, PEHP6001, "How To Take A Good Oil Sample"

Coolants

- Special Publication, PEHP7057, "Data Sheet - S·O·S Coolant Analysis"
- Special Publication, SEBD0970, "Coolant and Your Engine"

Miscellaneous

- Service Manual, REG1139F, "Service Manual Contents Microfiche"
- Service Manual, UENR0651, "C3.4B Industrial Engines"
- Troubleshooting, UENR0612, "C3.4B Industrial Engines"
- Systems Operation, Testing, and Adjusting, UENR0620, "C3.4B Industrial Engines"
- Specifications, UENR0619, "C3.4B Industrial Engines."
- Disassembly and Assembly, UENR0621, "C3.4B Industrial Engines"
- Specifications, SENR3130, "Torque Specifications"

- Special Publication, SEBF8029, "Index to Guidelines for Reusable Parts and Salvage Operations"
- Special Instruction, SEHS9031, "Storage Procedure for Caterpillar Products"
- Special Publication, SEBU6251, "Caterpillar Commercial Diesel Engine Fluids Recommendations"
- Special Instruction, SEHS7633, "Battery Test Procedure"

Index

A

After Starting Engine	54
After Stopping Engine	63
Aftercooler Core - Clean/Test (Air-To-Air Aftercooler)	75
Aftercooler Core - Inspect	75
Alarms and Shutoffs	33
Alternator - Inspect	75
Alternator and Fan Belts - Replace	75

B

Battery - Replace	76
Battery Electrolyte Level - Check	77
Battery or Battery Cable - Disconnect	77
Before Starting Engine	15, 52
Burn Prevention	10
Aftertreatment System	11
Batteries	11
Coolant	10
Diesel Fuel	11
Induction System	10
Oils	11

C

Cold Weather Operation	59
Hints for Cold-Weather Operation	59
Idling the Engine	60
Recommendations for Coolant Warm Up	60
Recommendations for the Coolant	59
Viscosity of the Engine Lubrication Oil	59
Cold Weather Starting	52
Configuration Parameters	49
Customer Specified Parameters	49
System Configuration Parameters	49
Coolant (DEAC) - Change	78
Cooling Systems with Heavy Deposits or Plugging	79
Drain	78
Fill	79
Flush	78
Coolant (ELC) - Change	80
Drain	80
Fill	81
Flush	81
Coolant Extender (ELC) - Add	81
Coolant Level - Check	82
Coolant Sample (Level 1) - Obtain	83

Coolant Sample (Level 2) - Obtain	84
Cooling System Supplemental Coolant Additive (SCA) - Test/Add	84
Add the SCA, If Necessary	85
S·O·S Coolant Analysis	84
Test for SCA Concentration	84
Crushing Prevention and Cutting Prevention ..	13
Customer Assistance	111
Outside of the USA and of Canada	111
USA and Canada	111
Customer Service	111

D

Diagnostic Lamp	48
Diesel Particulate Filter - Clean	85
Diesel Particulate Filter Regeneration	55
Modes of Regeneration	56
Regeneration	55
Regeneration Indicators	56
Regeneration Switch	56
Regeneration System Warning Indicators ..	56
Driven Equipment - Check	86

E

Electrical System	16
Grounding Practices	16
Emergency Stopping	63
Emergency Stop Button	63
Emissions Certification Film	30
Emissions Warranty Information	109
Engaging the Driven Equipment	58
Engine - Clean	86
Aftertreatment	87
Engine Air Cleaner Element (Single Element) - Inspect/Clean/Replace	87
Engine Air Cleaner Service Indicator - Inspect	87
Test the Service Indicator	87
Engine Air Precleaner - Check/Clean	88
Engine Crankcase Breather Element - Replace	88
Engine Breather	88
Engine Diagnostics	48
Engine Electronics	17
Engine Mounts - Inspect	89
Engine Oil and Filter - Change	90
Drain the Engine Lubricating Oil	91

Engine Oil Service Reset.....	93	Remove the Element.....	96
Fill the Oil Pan.....	92	Fuel System Primary Filter/Water Separator - Drain.....	98
Replace the Oil Filter.....	91	Fuel System Secondary Filter - Replace.....	98
Engine Oil Level - Check.....	89	Install the Element.....	99
Engine Oil Sample - Obtain.....	90	Remove the Element.....	99
Obtain the Sample and the Analysis.....	90	Fuel Tank Water and Sediment - Drain.....	100
Engine Operation.....	55	Drain the Water and the Sediment.....	100
System Check.....	55	Fuel Storage Tanks.....	100
Engine Operation with Active Diagnostic Codes.....	48	Fuel Tank.....	100
Engine Operation with Intermittent Diagnostic Codes.....	48	G	
Engine Rating Conditions.....	110	Gauges and Indicators.....	33
Engine Rating Definitions.....	110	Aftertreatment Lamps.....	34
Engine Ratings.....	110	Indicator Lamps.....	34
Engine Starting.....	15, 52	General Hazard Information.....	6
Engine Stopping.....	16, 63	Containing Fluid Spillage.....	8
F		Dispose of Waste Properly.....	9
Fan Clearance - Check.....	94	Fluid Penetration.....	8
Fault Logging.....	48	Inhalation.....	9
Features and Controls.....	33	Pressurized Air and Water.....	8
Fire Prevention and Explosion Prevention.....	11	Static Electricity Hazard when Fueling with Ultra-low Sulfur Diesel Fuel.....	8
Ether.....	13	General Information.....	19
Fire Extinguisher.....	13	H	
Lines, Tubes, and Hoses.....	13	High Pressure Fuel Lines.....	14
Regeneration.....	13	Hoses and Clamps - Inspect/Replace.....	100
Fluid Recommendations.....	65	Replace the Hoses and the Clamps.....	101
Coolant.....	68	I	
Engine Oil.....	65	Important Safety Information.....	2
Fuel.....	67	L	
Lubricating Grease.....	67	Lifting and Storage.....	32
S·O·S Coolant Analysis.....	68	M	
Foreword.....	4	Maintenance Interval Schedule.....	73
California Proposition 65 Warning.....	4	Commissioning.....	74
Literature Information.....	4	Daily.....	73
Maintenance.....	4	Every 1000 Service Hours.....	73
Maintenance Intervals.....	4	Every 12 000 Service Hours or 6 Years.....	74
Operation.....	4	Every 1500 Service Hours.....	73
Overhaul.....	4	Every 2000 Service Hours.....	73
Safety.....	4	Every 250 Service Hours.....	73
Fuel and the Effect from Cold Weather.....	61	Every 3000 Service Hours.....	73
Fuel Conservation Practices.....	58	Every 3000 Service Hours or 2 Years.....	74
Fuel Related Components in Cold Weather ...	62	Every 4000 Service Hours.....	74
Fuel Filters.....	62		
Fuel Heaters.....	62		
Fuel Tanks.....	62		
Fuel System - Prime.....	95		
Fuel System Primary Filter (Water Separator) Element - Replace.....	96		
Install the Element.....	97		

Every 50 Service Hours or Weekly	73	Product Lifting	32
Every 500 Service Hours	73	Product Storage	32
Every 500 Service Hours or 1 Year	73		
Every 6000 Service Hours or 3 Years	74	R	
Every Week	73	Radiator - Clean	104
Overhaul	74	Radiator Pressure Cap - Clean/Replace.....	105
When Required.....	73	Radiator Restrictions	61
Maintenance Log.....	114	Reference Information.....	31
Maintenance Recommendations	70	Record for Reference	31
Maintenance Records	113	Reference Information Section	110
Maintenance Section.....	65	Reference Material	115
Model View Illustrations	19	Coolants.....	115
Engine and Aftertreatment.....	19	Lubricants	115
Engine View with Through Flow Diesel		Miscellaneous.....	115
Particulate Filter.....	25	Reference Materials	113
Engine View with Wall Flow Diesel Particulate		Refill Capacities.....	65
Filter	23	Cooling System.....	65
Monitoring System.....	34	Lubrication System	65
Programmable Options and Systems			
Operation	35	S	
Mounting and Dismounting	13	Safety Messages.....	5
		Universal Warning	5
O		Safety Section	5
Operation Section.....	32	Self-Diagnostics	48
Ordering Replacement Parts.....	111	Sensors and Electrical Components.....	36
Overhaul Considerations.....	101	Full Engine Views	36
Oil Consumption as an Overhaul		Sensors and Electrical Components	
Indicator	102	(Aftertreatment)	45
Overhaul Recommendation.....	102	Differential Pressure sensor	47
Overspeed.....	35	Through Flow Aftertreatment.....	46
Oxygen Sensor - Replace	104	Wall Flow Aftertreatment	46
		Severe Service Application	72
P		Improper Maintenance Procedures	
Plate Locations and Film Locations		(Maintenance Procedures Which May	
(Aftertreatment)	29–30	Contribute to a Severe Service	
Through-Flow Diesel Particulate Filter		Application)	72
(DPF)	30	Severe Environmental Factors	72
Wall Flow Diesel Particulate Filter (DPF)	29	Severe Operating Conditions	72
Plate Locations and Film Locations (Engine)..	28	Starting Motor - Inspect.....	105
Serial Number location	28	Starting the Engine.....	53
Product Description.....	25	Starting the Engine	53
Aftermarket Products and Caterpillar		Starting with Jump Start Cables.....	53
Engines	27	Stopping the Engine	63
Electronic Engine Features	26	System Pressure Release.....	70
Engine Cooling and Lubrication	27	Coolant System	70
Engine Diagnostics.....	26	Engine Oil	70
Engine Service Life.....	27	Fuel System.....	70
Engine Specifications	25		
Product Identification Information	28		
Product Information Section.....	19		

T

Table of Contents	3
Turbocharger - Inspect	105

W

Walk-Around Inspection	106
High Pressure Fuel Lines	107
Inspect the Engine for Leaks and for Loose Connections	106
Warranty Information	109
Warranty Section	109
Water Pump - Inspect	107
Welding on Engines with Electronic Controls	70

Product and Dealer Information

Note: For product identification plate locations, see the section "Product Identification Information" in the Operation and Maintenance Manual.

Delivery Date: _____

Product Information

Model: _____

Product Identification Number: _____

Engine Serial Number: _____

Transmission Serial Number: _____

Generator Serial Number: _____

Attachment Serial Numbers: _____

Attachment Information: _____

Customer Equipment Number: _____

Dealer Equipment Number: _____

Dealer Information

Name: _____ Branch: _____

Address: _____

Dealer Contact

Phone Number

Hours

Sales: _____

Parts: _____

Service: _____

